

Historic City Cemetery *Preservation Assessment & 5-Year Preservation Plan*



Prepared for
The City of Sacramento

by
Katharine Untch, MA, CAS, Fellow AIC
Conservation Strategies
Art Architecture Archaeology
Alameda, California

Revised January 1, 2021

Table of Contents

I.	Executive Summary	4
A.	Objective	4
B.	Goals.....	4
C.	Decision-making	4
D.	Recommendations	5
II.	Introduction.....	6
III.	Methodology	7
A.	Project Team	8
B.	Background Documents	9
IV.	Stakeholders.....	10
A.	City of Sacramento	10
B.	Family Plots	11
C.	Volunteers	11
V.	The Site.....	12
A.	Timeline.....	14
B.	Period of Significance	15
A.	Historically Significant Features	15
I.	Mission and Vision.....	18
A.	Evolving Aesthetics.....	18
II.	Security.....	20
A.	Finding a Balance.....	201
B.	Historic Non-Compliance.....	201
III.	Preservation	23
A.	Preventive Conservation	23
1.	Risks.....	23
2.	Priorities	24
B.	Documentation.....	24
C.	Maintenance	25

1. History.....	25
2. Horticulture.....	26
3. Irrigation.....	27
D. Treatment.....	28
1. History of Treatments	29
IV. Current Conditions	31
A. Vegetation	31
1. Trees.....	32
2. Trellises	33
B. Drainage	33
C. Structures	34
D. Paving	35
E. Walls	36
F. Monuments and Markers.....	36
G. Fences.....	38
H. Education and Training.....	38
V. References.....	39

Appendices

Appendix A: 5 Years Recommendations Chart

Appendix B: Preservation Brief 2: Repointing Mortar Joints in Historic Masonry Buildings. Robert C. Mack, FAIA, and John P. Speweik. 1998.

Appendix C: Preservation Brief 38: Removing Graffiti from Historic Masonry. Martin E. Weaver. 1995.

Appendix D: Preservation Brief 40: Preserving Historic Ceramic Tile Floors. Anne E. Grimmer and Kimberly A. Konrad

Appendix E: Preservation Brief 48: Preserving Grave Markers in Historic Cemeteries. Mary F. Striegel, Frances Gale, Jason Church, & Debbie Dietrich-Smith.

Appendix F: Matero, Frank G. and Judy Peters. "Survey Methodology for the Preservation of Historic Burial Grounds and Cemeteries." In APT Bulletin, Vol. 34, No. 2/3 (2003), pp. 37-45.

Appendix G: Best Practice Recommendations for Cleaning Government Issued Headstones. Mary F. Striegel, 2011.

Appendix H: A Glossary of Historic Masonry Deterioration Problems and Preservation Treatments. Anne E. Grimmer. 1984, reprinted.

Appendix I: Bylaws of the Old City Cemetery Committee, 2002.

I. Executive Summary

A. Objective

To achieve compliance with current best practices for preservation of historically significant features of the Historic City Cemetery.

B. Goals

To update the twelve-year-old 2007 Master Plan.

- To implement preservation best practices.
- To reconcile the “concepts of the Cemetery as an outdoor museum and garden [as] a key part of the future of the Cemetery”ⁱ
- To balance horticultural and cemetery maintenance practices in a manner that will ensure the long-term preservation of the historically significant features.
- To utilize this Preservation Assessment and the recently completed Historic City Cemetery Operations and Assessment Study (“Operations Assessment Study”) for potential grant applications, which in turn, would be used to support the preservation of the Cemetery’s historic elements.

C. Decision-making

For preservation purposes, separate issues such as conservation, infrastructure, facilities, horticulture, management, and programming, must be taken into consideration collectively to find viable solutions. For example, any type of irrigation system should not be installed without consulting the conservator to avoid any accelerated deterioration of historic masonry. Similarly, all new or revised horticulture practices should be reviewed by an historic landscape architect who should also be consulting with the conservator.

In 2019 the City created a new position and hired an experienced Cemetery Manager who oversees the Cemetery operations and maintenance. The Cemetery Manager, City Historian, City Preservation Director, Parks Maintenance Superintendent and specialists in the Youth, Parks, & Community Enrichment (YPCE), provide a substantial internal management team. Including the expertise of a historic landscape architect and a conservator will significantly help with balancing decision-making for preservation purposes, as well as implementation of the recommendations contained in the Operations Assessment Study and this Preservation Assessment to help improve the Historic City Cemetery for the benefit of the public.

D. Recommendations

As a designated historic site and registered national landmark, all practices at the Historic City Cemetery are to be in compliance with the following guidelines:

- *Secretary's Standards for the Treatment of Historic Properties with Guidelines for the Treatment of Cultural Landscapes*
- *American Institute for Conservation Code of Ethics and Guidelines for Practice.*

Incorporate these standards and codes into City Ordinance 2002-020 (especially section 12.68.070 Maintenance by City Cemetery Staff), the Cemetery Manager's Job Description, the Youth, Parks, & Community Enrichment Department (YPCE), all other City departments related to the cemetery, and all Bylaws of organizations contributing to maintenance and preservation of the cemetery.

A summary of recommended action items is presented as a *5-Year Preservation Plan* that is appended to this report. The 5-Year Plan is intended as a guide to indicate priorities via sequencing, with highest priorities to be accomplished sooner, while remaining priorities can be achieved as feasible; that is, as funding becomes available.

In general, action items can be phased to reflect priorities as follows:

- Phase I** Planning, Policy, and Management Updates, Security Improvements
- Phase II** Site Features Survey Documentation and Conceptual Cost Estimating
- Phase III** Fundraising and Grant Writing
- Phase IV** Training and Implementation.

II. Introduction

The Sacramento Historic City Cemetery, located at 1000 Broadway and 10th Street, is the oldest existing cemetery in Sacramento, California and the oldest public cemetery west of the Mississippi River. Established in 1849, the Cemetery is listed on the National Register of Historic Places, is a California Historical Landmark, and a City of Sacramento historic resource as the Historic City Cemetery Historic District. The City Council approved Master Plan (2007)ⁱⁱ clearly outlines the site history and significance and makes recommendations for ongoing maintenance and improvements. The more recent Operations Assessment Study (2019) provides additional recommendations for Cemetery operations.ⁱⁱⁱ

The Cemetery is maintained by a team of City departments and volunteer groups that are currently working toward mutual objectives and goals regarding the site presentation, history and cemetery use. As an historically significant site, City staff strives to maintain the cemetery in accordance with the Secretary of the Interior's Standard for the Treatment of Historic Properties. The landscape maintenance practices over the years have helped to maintain the site; now those practices are being re-evaluated to ensure that they preserve the cemetery's historic features, consistent with preservation standards for National Register-listed properties. City staff has been developing improved policies and procedures consistent with such best practices. Site appropriate solutions will need to be implemented if the historically significant features of the site are to be preserved, and the historic designation of the Cemetery maintained.

As part of that endeavor, the City team contracted with **Conservation Strategies Art Architecture Archaeology** to provide a current assessment of the significant historic features and make recommendations for their preservation. The conservator, Katharine Untch, reviewed current conditions, including physical historic features, current and planned maintenance, irrigation, and horticultural activities, with regard to their impact on historic features.

This report describes observations, recommendations, and prioritized action items to help align activities to be more compliant with cemetery preservation best practices, existing City Code, the 2007 Master Plan, and the Operations Assessment Study. Issues with historic feature conditions were noted by typology but were not quantified at this point. Later assessments should include more detailed quantification for use as planning tools for fundraising and future maintenance.

This report is not intended to replace the 2007 Master Plan. It is intended to be used as an updated supplement. Many of the recommendations from the now twelve-year-old Master Plan are still pertinent; while some recommendations require updating, either because best practices have improved over the years, or because certain tasks have been completed. A list of updated recommendations, that captures the 2007 Master Plan recommendations, is appended to this report. Furthermore, the appended recommendations list now has an associated timeline in an effort to suggest priorities and sequencing.

III. Methodology

The consulting conservator reviewed seminal background documents, met with City staff, and toured the cemetery site while taking images of typical current conditions. The conditions noted are limited to typical conditions observed during the two-day site visit and do not include any quantification at this time.

The requested scope of work included providing more in-depth recommendations for day-to-day site maintenance and repairs, such as how to repair tumbling masonry walls and broken headstones; however, larger issues currently remain unresolved within the realm of daily operations, despite the professionalism of the City staff and their desire to achieve best practices. These issues are further discussed in this report.

Recommendations are presented at the end of each report section in *italics*. Compiled recommendations are presented as an appendix as Action Items. Furthermore, the appended recommendations list now has an associated timeline in an effort to suggest priorities and sequencing. The list is available as a deliverable in Microsoft Excel format that can be updated electronically as a working document and/or uploaded into a project management software such as Microsoft Project for ongoing operations management.

A. Project Team

City Representatives

Marcia Eymann, City Historian
City of Sacramento
Convention & Cultural Services
551 Sequoia Pacific Blvd.
Sacramento, CA 95811
916-808-5960
meymann@cityofsacramento.org

Andrew S. MacVicar
City of Sacramento
Manager, Historic City Cemetery
1000 Broadway
Sacramento, CA 95818
916-224-7728
amacvicar@cityofsacramento.org

Carson Anderson
City of Sacramento
Preservation Director
916-808-8259
canderson@cityofsacramento.org

Gary Hyden
City of Sacramento
Supervising Landscape Architect
916-808-1949
GHyden@cityofsacramento.org

Tony Ulep
City of Sacramento
Parks Superintendent
916-808-4070
TUlep@cityofsacramento.org

Jorge Acevedo
GIS Specialist II, Information Technology Dept.
915 I Street, 3rd Floor
Sacramento, CA 95814
916-808-8927
jacevedo@cityofsacramento.org

Consultant

Katharine Untch, MA, CAS, Fellow AIC
Principal Conservator
Conservation Strategies Art Architecture Archaeology
Alameda, CA 94501
650-503-4002
katharine@cultureconservation.com

B. Background Documents

Several background documents and references are provided in the 2007 Master Plan. Background documents provided for this current conservation assessment are listed below with some annotations.

2002 City Ordinance 2002 - 020 – Cemetery Use / Operations Policies

2007 The Sacramento Historic City Cemetery Master Plan, prepared by the City of Sacramento in collaboration with Royston, Hanamoto, Alley and Abey (RHAA).

The Cemetery largely operates following the 2007 Master Plan, which also serves as a Master Preservation Plan. Written in 2007, some of the recommendations have been implemented. Other recommended tasks remain pending, while some recommendations may require reshuffling priorities based on current issues and needs. The bulk of information provided in the 2007 Master Plan remains current and viable, especially the historic contexts and characteristic descriptions of the site, as noted below.

“The consensus is for the site to be a community resource as a historic place as well as a place for horticulture. The principal goals of the Master Plan are to restore and preserve the elements in the Cemetery and to create space and/or facilities for public access and use for purposes other than burial.”^{iv}

“Though the Master Plan provides clear direction for the site, in the form of physical goals and objectives, it lacks strategies to implement the Plan’s proposed vision for the Cemetery. The issues of cemetery management and operation, relationships with stakeholders, and staffing should be additionally addressed to guide the direct implementation of the Master Plan’s recommendations.”^v

“In Section 3 of the Master Plan, the physical issues facing the stakeholders are identified along with proposed action plans. The Appendix provides information on the planning process, background on City codes, assessment reports on the site’s trees, preservation issues, and a detailed infrastructure report.”^{vi}

2019 Sacramento Historic City Cemetery Assessment and Operations (Operations Assessment Study) by RHAA Landscape Architects and L.F. Sloane Consulting Group, dated May 2019.^{vii}

The Operations Assessment Study provides background documentation, clearly identifies existing stakeholders including City and volunteer entities, and provides appropriate guidelines for cemetery management and general maintenance.

2019 City Cemetery Volunteer Orientation Handbook, City of Sacramento Department of Youth, Parks & Community Enrichment, February 2019.

This document provides adequate protections ‘in writing’ for volunteer activities.

2016 Cemetery Trimming, Pruning and Planting Guidelines

2019 Draft Plant Maintenance & Pruning Guidelines for the Protection of Historic Resources (Technical Advisory Committee (TAC) sub-committee).

IV. Stakeholders

Stakeholder include a team of City departments, City and office staff, maintenance crew members, plot owners, and volunteers.

See Organizational Chart.^{viii}

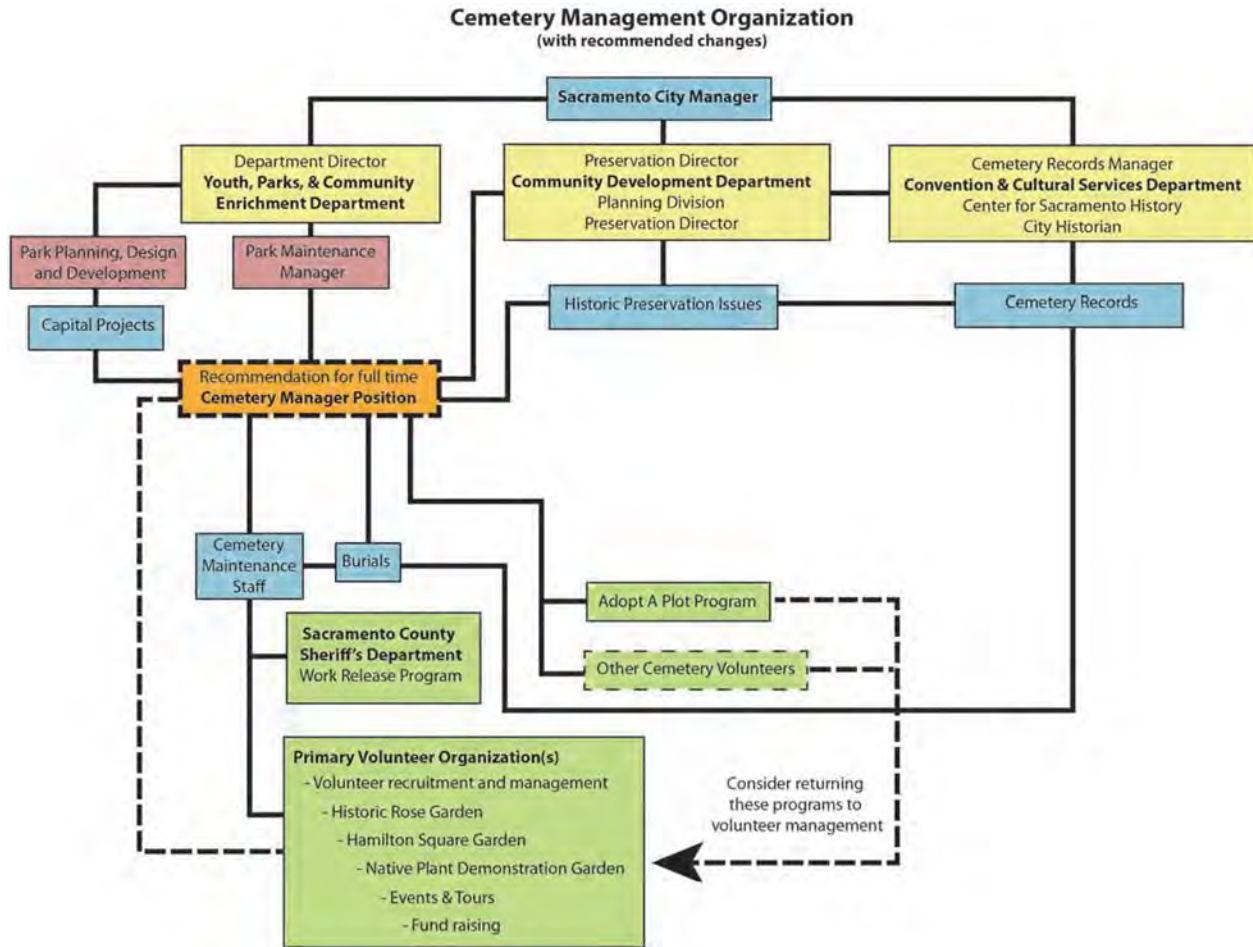

Cemetery Management Organization Chart^{ix}

A. City of Sacramento

The City of Sacramento owns the Cemetery land and family burial plots are owned as easements under state law. The City is responsible for defining site mission and vision in compliance with both national, state, and local historic designations, state cemetery laws, along with site security, operations and maintenance oversight.

B. Family Plots

The Cemetery burial plots have all been sold. A few plots still have room for more burials (i.e., cremated remains), and plot owners can sell their plots if the plot has not been used for a burial. The City oversees any new burials. Families often visit and have planted vegetation or change vegetation within their plot. The vegetation in some plots are maintained by the plot owner while other plots are maintained by a volunteer assigned by the City.

C. Volunteers

Organized in 1986 and incorporated as a non-profit in 2002, The Old City Cemetery Committee (OCCC) is the main volunteer organization supporting the Cemetery. The 2007 Master Plan describes the OCCC and encourages restructuring and increased participation, consistent with other non-profit organizations that operate other City facilities such as the Zoo and Fairytale Town.

At the time that the 2007 Master Plan was written, the vision was to have the non-profit organization grow and take on a larger role in management of the cemetery. With YPCE's assumption of the Cemetery operation and maintenance in 2015 from the Convention and Cultural Services Department, prompted by the Cemetery being listed on the National Register (2014), the City has taken back the overall management of the cemetery. The City has restructured the volunteer program so that it is overseen by the City Cemetery Manager rather than volunteers supervising volunteers.

Priorities and methods for landscape maintenance need to be balanced in practice if the historically significant features of the Cemetery are to be preserved.

Recommendations

Review current goals and tasks of City volunteers to ensure they are in line with the 2007 Master Plan and Updates, and the Operations Assessment Study.

Follow preservation priorities and integrate feasible and sustainable goals into Cemetery maintenance practices, including adopt-a-plot and all other programs which may involve work that could impact the significant historic features.

The City, as owner and primary steward of the Cemetery, must take steps to mitigate the risks of damage to the original significant historic features. The City must be in compliance with current best practices for preservation of National Register-listed properties.

V. The Site

The Sacramento Historic City Cemetery is well defined in the 2007 Master Plan and other documents. The 44 acres comprising the site is boarded on the south by the Masonic Cemetery, with the Old Fellows Lawn Cemetery at the southernmost end of the combined cemetery site.



Map of Historic City Cemetery Historic District

The Cemetery includes landscaped areas known as The Pioneers' Section, the Heritage Rose, Hamilton Square, Old Masonic Plot, the Native Plant Demonstration Collect, as well as all other landscaped areas within its borders.



- 1 Pioneers' Section**
 - plots, turf, and paths maintained by the Sacramento Pioneer Association
 - trees maintained by City
 - 2 Historic Rose Garden**
 - plots maintained by Historic Rose Garden group, a committee of the Old City Cemetery Committee
 - turf, paths, and trees maintained by City
 - 3 Hamilton Square**
 - plots maintained by Old City Cemetery Committee and the Sacramento Perennial Plant Club
 - turf, paths, and trees maintained by City
 - 4 Old Masonic Plot**
 - plots, turf, and paths maintained by the Masonic Cemetery
 - trees maintained by City
 - 5 Native Plant Demonstration Gardens**
 - plots maintained by the California Native Plant Society
 - turf, paths, and trees maintained by City
 - All Other Cemetery Areas**
 - plots maintained by city or Adopt-A-Plot volunteers
 - turf, paths, and trees maintained by City
 - with assistance from Sheriff's program
- Monuments, Walls, and Fences**
 - maintained by City
 - monument repair is funded by Old City Cemetery Committee
 - Roads and Pathways**
 - maintained by City
 - Irrigation System**
 - maintained by City
 - irrigation in Rose Garden is maintained by volunteers, in coordination with City
 - Cemetery Records System**
 - maintained by City



Sacramento Old City Cemetery
Maintenance Responsibilities

Map of Maintenance Responsibilities, May 2019 ❧

A. Timeline

The following timeline builds upon the timeline from 1849 to 2002 as presented in the 2007 Master Plan.^{xii} Note that portions of the Cemetery have changed over time with regard to size, stewardship, aesthetics and maintenance.

- 1849 Opening of cemetery, 10 acres. Beginning of historic period of significance.
- 1850 Cholera epidemic.
- 1852 Engraving showing one pyramid, fenced plots, headstones, few plantings. Description references the possibility of families beautifying graves by planting shrubbery and palings (picket fences).
- 1856 Cemetery Superintendent hired. Formal design of plots and tiers established with sections defined for Odd Fellows, Freemasons, etc. Hillsides were terraced to create individual plots with retaining walls of brick or stone. Paths or carriage ways were provided on a grid.
- 1859 Old Masonic Cemetery established.
- 1861 Odd Fellows Cemetery established.
- 1860 2000 ft. lead pipe for irrigation, 300 – 400 shade and ornamental trees.^{xiii}
- 1860-1870 Stereograph image of cemetery showing heavy vegetation, shrubbery, and trees.
- 1872 “[T]he desert has been made to blossom as the rose” with irrigation laid out for the purpose of horticulture.^{xiv}
- 1875 Sections of historic cemetery sold to Masons and Odd Fellows who developed lawn style cemeteries which were easier to maintain.
- 1880 Cemetery expanded to 60 acres.
- 1878 Bell Conservatory constructed, used to grow flowers for the cemetery.
- 1893 Stone mortuary chapel constructed.
- 1938 (circa) aerial photo showing trees lining roadways. Very few small plantings or shrubbery.
- 1900 – 1980s? cemetery decline in care and maintenance
- 1902 Earliest known extant map of cemetery still used today, earlier maps must have existed but were not found.
- 1938 Image showing mostly grass, a few trees, with a few small plantings.^{xv}
- 1949 10th Street gate and entry removed for widening of Broadway
- 1953 Aerial photograph shows trees and grass with little shrubbery
- 1957 The Sacramento City Cemetery was designated as State Historic Landmark under the sponsorship of the Native Sons of the Golden West and the Native Daughters of the Golden West. End of current historic period of significance.

- 1986 Concerned citizens organized the Old City Cemetery Committee (OCCC) in reaction to the deteriorating condition and vandalism.
- 1990s Planting of the Rose Garden began.
- 2002 City Ordinance 2002-020 is enacted to address cemetery programming, maintenance and vandalism concerns
- 2002 OCCC becomes an independent nonprofit organization.
- 2007 Master Plan.
- 2014 National Register of Historic Places listing.
- 2016 Cemetery Trimming, Pruning and Planting Guidelines
- 2019 Assessment and Operations Recommendations. Hired Cemetery Manager.
- 2019 Draft Plant Maintenance & Pruning Guidelines for the Protection of Historic Resources (TAC sub-committee) resulting from an effort to balance preservation of cemetery grave markers, monuments and historic hardscape features with the burgeoning volunteer rose cultivation activities.

B. Period of Significance

As defined in the 2007 Master Plan, the Period of Significance is determined as 1849 to 1957.^{xvi}

“The programming of the cemetery has changed over the years, reflecting societal and religious influences, as well as accommodating needs.”^{xvii}

A. Historically Significant Features

As noted in the 2007 Master Plan, the most historically significant features in the cemetery are the monuments, comprising stone and wood grave markers, sculptures and carvings, and mausoleums.^{xviii}

In order to preserve the historic aspects of the Cemetery, these significant features are to be documented and maintained using current best practices.

The 2007 Master Plan also states that: “Gardens shall be contribute to, or complement, the historic character of the cemetery.”^{xix} This means that the cemetery is first a historic burial ground that is complemented by the garden like plantings that are appropriate to the period of significance. Horticultural activities are to be designed, managed, and maintained in deference to preserving the unique and original Historic City Cemetery features.

Of the historic horticultural material, only the historic elm trees are called out.^{xx} The 2007 Master Plan states that “[t]he trees, shrubs and floral plantings will be expanded and protected.”^{xxi} However, there are no existing historic horticultural or landscape plans showing plant species by type or locations. Trees were generally documented by species in the 2007 Master Plan, along with a general description that smaller

shrubby and plantings would have likely been provided by individual family plot owners at their own choosing.

“This is likely not that different than the conditions in the cemetery when it was tended primarily by plot owners.”^{xxii}

Historic vegetation is included in the list of *Character Defining Features* and is referenced by a 1953 aerial photo.^{xxiii}



1953 Aerial Photo ^{xxiv}



c.2001 Aerial Photo ^{xxv}

By the time the 1953 aerial photo was taken (still within the period of significance) only trees and small shrubbery were visible. There may be small plantings that do not show in the image, however, it is clear that there is no significant overgrowth of vegetation, and a significant number of stone markers and monuments remained visible. The c. 2001 aerial photo shows added trees and shrubbery, along with growth of pre-existing plants. This contrasts with today where overgrowth hides some of the stone markers and monuments.

Recommendations

Remove and or trim back non-historic vegetation that is impeding (obstructing or potentially damaging) on historically significant features (i.e., monuments, markers, walls, and fencing).

Prune vegetation that remains from period of significance (prior to 1957 that shows in 1953 aerial photo) to prevent intrusion on historically significant features.

In some cases, historic vegetation that has been lost or is in decline, namely the elm trees, can be replaced in kind if the new trees are planted in locations that do not impinge on historically significant features, including future root growth impinging on historic features.

See further recommendations under section below on “Maintenance”.

I. Mission and Vision

One of the challenges the Cemetery operation currently faces is multiple interpretations of mission and vision from the different stakeholders.

To date, there is no defining current or future aesthetic goal or parameters for the Historic City Cemetery put forth by a professional historic landscape architect and ratified by the City. The 2007 Master Plan documents the available history that includes changes in aesthetics over time; but does not go so far as to articulate a future vision regarding landscape aesthetics, educational programming, public events, etc. for the Cemetery.

The horticultural history has been reconstructed as best possible for the cemetery site as a whole, but there is no existing historic landscape architectural plan showing exact species and locations of horticultural material. There is no compiled documentation of current or historic horticultural materials at the plot level. There is no vision document defining horticultural goals that are rectifiable with the overall site preservation goals. In addition, there is no defining articulation regarding the impact of current horticultural activities on the preservation of historically significant features.

A professional intent is evident among City staff to preserve the historic features of the Cemetery. Priorities and methods for landscape maintenance need to be balanced in practice if the historically significant features of the Cemetery are to be preserved for future enjoyment.

A. Evolving Aesthetics

The opening description of the Cemetery site on the Wikipedia website states the following:

“The Sacramento Historic City Cemetery (or Old City Cemetery), located at 1000 Broadway, at 10th Street, is the oldest existing cemetery in Sacramento, California. It was designed to resemble a Victorian garden and sections that are not located in level areas are surrounded by brick or concrete retaining walls to create level terraces. The cemetery grounds are noted for their roses which are said to be among the finest in California.”^{xxvi}

Historic cemeteries frequently change with intrinsic societal aesthetics, as has this cemetery over time. It is clear from the 19th century documentation that an early concept for the cemetery was to provide an oasis of sorts, a garden for visitors, as well as an attraction for selling plots. However, periods of evolving aesthetics have been recognized throughout the defined 108-year period of significance. In the 1953 aerial photograph, some of the vegetation in the cemetery had been removed. By the early 1980s, much of the vegetation in the Cemetery had been removed, and some of the plots had been cemented over. While this may have been done initially for the purposes of lower maintenance, the results were an ever-changing aesthetic within the designated historic period of significance.

Similarly, the overall aesthetic for an historic cemetery may vary with regard to level of cleaning and presentation. A generally accepted aesthetic for a western United States 19th to 20th century Pioneer Era cemetery follows terminology that has been utilized by the California State Parks of “arrested decay”. In other words, visitors like to see that there is an historic “patina” or certain “wear” on the cemetery features.

Shiny bright marble headstones might be more appropriate in a 20th century military cemetery, while marble markers in a Pioneer Era cemetery retain expectations of having some wear, dirt, staining, and minor biological growth. A balance must be struck between permissible wear for aesthetic purposes and performing preventive or interventive maintenance and repairs to slow or mitigate deterioration.

Some tend to prioritize the cultivation of the plant materials, particularly the roses, above the preservation needs of a designated historic cemetery site. The conflict in purposes and goals is understandable given the beauty of the gardens and a precedence for a plethora of freely grown flowering plants especially in Victorian Era cemeteries. However, cemetery aesthetics often change over time, as has the Historic Sacramento Cemetery. At one point most of the horticultural material other than trees were removed and the entire historic cemetery was planted with grass. Over time, some of the plots were filled in with concrete. Aesthetics changed both as a result of lack of maintenance, the need to lower maintenance, as well as societal changes in aesthetics throughout the 20th century as Victoriana was supplanted by minimalist and modernist design trends in the first half of the 20th century. By the 1960's and 1970's a 'live and let live' societal trend capped the most recent era of neglect at the cemetery until the 1980s when volunteers stepped in to help reverse neglect and address vandalism issues.

Current horticultural activities are negatively impacting preservation of historic features. Several of the features are deteriorating, largely in part due to plant overgrowth, plant root systems, trellises, concrete slabs and over-frequent watering.

Recommendations

Clarify mission, vision, and aesthetic horticultural goals for the historic cemetery with input from a historic landscape architect experienced with historic cemeteries based on available historic documentation.

Document current locations and conditions of historic features and plant material. Research historic documentation of individual plots where information is missing. This can be done in conjunction with conservation and horticulture professionals working with volunteers, if needed. The Conservator and Horticulturalist can use the survey data to determine projected changes, maintenance, repairs or treatment to historic features and vegetation. Survey documentation can be uploaded to a cemetery-wide database. The City Historian can oversee a registrar familiar with collections management systems that can be utilized for retaining and updating documentation to include outcomes of the surveys, photographs, news clippings and other archival material. Digitize existing archival material to be retrievable in a multitude of ways (using data field search capabilities) such as by family plot name, plot numbers, plant material type, headstone, or wall type, etc.

Use the survey and research data to develop a plant maintenance protocol with the input of the historic landscape architect and conservator.

To enhance and promulgate historic preservation of the Cemetery, consider making appropriate portions of the archives accessible on a web-based platform to the public. Consider including condition histories and documentation generated by the survey.

Update Wikipedia description to better reflect historic aspects of the Cemetery.

II. Security

A. Finding a Balance

The 2007 Master Preservation plan notes that “All activities, programs, and proposals shall be respectful to the traditional cemetery functions...[and]...The cemetery is a historic resource and all activities, programs, and proposals shall preserve or enhance the historic integrity of the Cemetery.” ^{xxvii}

All work in the cemetery as part of Adopt-a-plot and city maintenance must follow best practices for preservation of markers and monuments and approved by the Cemetery Manager. All plantings must be approved and follow guidelines for what types of plants are allowed and where they can be located in the burial plots.

- Burial locations in the plots should be used to determine where plantings can be placed.
- Historic grave markers cannot be moved to accommodate new plantings.
- Grave markers and monuments cannot be hidden under or behind vegetation.
- Mulch cannot be placed over ground markers, hiding them with the potential of negating their existence without conducting ground penetrating probes in the future (such as ground penetrating radar).
- Excessive moisture from sprinkler systems and plant watering, as well as overgrowth, are causing damage to many of the historic masonry and metal features of the cemetery and the issue needs to be addressed.

Recent City policy that no volunteer work is to be done on the premises without prior approval of the Cemetery Manager is a first step in ensuring the long-term preservation of all historic features..

B. Historic Non-Compliance

The 2007 Master Plan appropriately refers to the ***Secretary’s Standards for the Treatment of Historic Properties with Guidelines for the Treatment of Cultural Landscapes.*** ^{xxviii}

Of the listed Standards, current activities in the cemetery are ***not in compliance*** with the following:

Secretary of Interior Standard	Non-Compliance
1. A property will be used as it was historically or be given a new use that requires minimal change to its distinctive materials, features, spaces, and spatial relationships.	<i>New vegetation has been planted in burial plots without prior permission of either families or City staff. Vegetation has not always been maintained and have become overgrown, obscuring historic cemetery features. Consideration for historic accuracy</i>

	<i>has not been given to location of plantings, for example, new trees have been planted in the middle of plots, bushes have been planted directly on top of burials.</i>
2. The historic character of a property will be retained and preserved. The removal of distinctive materials or alteration of features, spaces, and spatial relationships that characterize a property will be avoided.	<i>Stone markers have been moved, sometimes in deference to installing new vegetation.</i>
3. Each property will be recognized as a physical record of its time, place, and use. Changes that create a false sense of historical development, such as adding conjectural features or elements from other historic properties, will not be undertaken.	<i>By City Ordinance staff retains the authority for reviewing changes to historic features; however, in the absence of specific policy guidance, no controls have been in place to mitigate changes to historic features or the addition of historic features from other sources. Newer plantings are not necessarily in keeping with historic types or locations.</i>
4. Changes to a property that have acquired historic significance in their own right shall be retained and preserved.	<i>New vegetation has been located in front of gravestone markers with overgrowth hiding stone markers.</i>
5. Distinctive materials, features, finishes, and construction techniques or examples of craftsmanship that characterize a property will be preserved.	<i>Grave markers have been moved and plant overgrowth has obscured and sometimes compromised historic features.</i>
6. Deteriorated historic features will be repaired rather than replaced. Where the severity of deterioration requires replacement of a distinctive feature, the new feature will match the old in design, color, texture, and, where possible, materials. Replacement of missing features will be substantiated by documentary and physical evidence.	<i>The non-profit OCCC uses its donations to directly contract with stone marker repair companies with minimum preservation knowledge. Although City preservation staff provides some oversight of those processes, conservators have not been retained to train staff or oversee cleaning or repair materials and methods.</i>
7. Chemical or physical treatments, if appropriate, will be undertaken using the gentlest means possible. Treatments that cause damage to historic materials will not be used.	<i>Repair contractors do not necessarily follow current best practices, and entities providing repairs may or may not be qualified to carry out treatment or repair design for historic fabric.</i>
8. Archeological resources will be protected and preserved in place. If such resources must be disturbed, mitigation measures will be undertaken.	<i>Markers have been moved occasionally in order to plant new vegetation. In addition to violating historic property standards for preservation, by moving grave markers and digging directly above or into burials with no archaeological knowledge of exact locations of burials pose the risk of gravesite desecration.</i>
9. New additions, exterior alterations, or related new construction will not destroy historic materials, features, and spatial relationships that characterize the property. The new work will be differentiated from the old and will be compatible with the historic materials, features, size, scale and proportion, and	<i>There is only limited professional oversight to repairs of historic markers, walls or other small features by City staff. The City has consulted with historic architects for repairs of historic building structures such as the mausoleums.</i>

massing to protect the integrity of the property and its environment.	
10. New additions and adjacent or related new construction will be undertaken in a such a manner that, if removed in the future, the essential form and integrity of the historic property and its environment would be unimpaired.	<i>While oversight procedures seem to be in place, at least in practice, for the cemetery building features (mausoleums), only limited oversight is currently provided for any of the other historic features such as walls, headstones, or monuments.</i>

It is clear from the evolved non-compliance at this particular cemetery, that securing the site and providing more controlled and supervised work activities may be the best way to protect the site while implementing preservation improvements.

Recommendations

Secure the site for public safety purposes.

Provide sign-in access for the general public and all visitors, including tour groups, contractors and volunteers.

Provide key code access to pre-approved staff only. Do not provide security access codes to volunteers.

Take further measures to mitigate non-approved and un-supervised activities that are not in alignment with historic preservation best practices and respect for the functionalities and context of a cemetery.

Implement a policy that no work is to be done on the premises without prior approval of the Cemetery Manager as currently required per City volunteer agreements.

All volunteer work is to be scheduled in advance. Volunteers to work only hours where supervision by City staff can be available.

Upon logging in, all volunteers are to indicate on the log in which plot they will be working and what tasks they will be conducting, even for routine tasks.

Document family permissions for changes to any vegetation within family plots, other than normal pruning.

Decisions about any ground disturbances including moving, removing, replacing, or adding plant materials, moving or shifting grave markers (even temporarily), requires approval of the Cemetery Manager and appropriate consultation with an archaeologist experience with cemeteries.

Consider installing security cameras, especially with signage indicating video surveillance. At many public sites and cemeteries, this has been shown to be a significant deterrent to vandalism; the signage even more so than operative cameras.

III. Preservation

A. Preventive Conservation

The concept of Preventive Conservation has emerged over the past twenty or so years in the museum and historic preservation arenas. The recognized need for more sustainable solutions to preservation has resulted in lowering costs for essentials such as environmental control and collections storage systems. Within the built heritage context, the same concepts apply how to maximize preservation and minimize costs using preventive measures. These same concepts can be helpful in preserving cemeteries.

By far, the most cost-effective method for preservation is to employ ongoing preventive measures, rather than waiting until features are so deteriorated or damaged that they require more expensive interventive repairs and/or replacements.

Current best practices for Preventive Conservation typically begin with a risk assessment. Outcomes help to prioritize the greatest and most frequent risks. Resources can then be put toward preventing the highest risk priorities first.

1. Risks

Typical risks for historic cemeteries include the following:

- Lawn mowers and/or weed whackers scraping or wearing away historic features.
- Moisture on masonry, metal, wood features accelerating deterioration of historic elements.
- Moisture contributing to biological growth that in turn contributes to weakening or wearing away of the stone.
- Moisture and uncoated metals contributing to corrosion.
- Vegetation clinging to masonry, metal, wood features contributing to weakening, wear and/or corrosion.
- Overhanging trees attracting birds and guano, tree sap and debris on historic elements.
- Overgrown trees and vegetation dislodging historic features such as paving, walls, and markers.
- Improper or lack of adequate drainage.
- Vandalism such as graffiti, breakage, theft.

In addition, there are typical public safety issues such as the following:

- Trip hazards from overgrown roots.
- Inadequately pruned or aging trees.
- Overgrowth providing hiding places for homeless.
- Hypodermic needles, human feces and urination from homeless.

2. Priorities

Several criteria may trigger maintenance activities, such as site appearance, individual families or groups that have specific aesthetic, task oriented and/or ritual expectations, availability of resources and funding, etc. Priorities for preservation are generally determined by deterioration risk factors and rates of decay. For example, an iron fence may appear corroded, but the fencing material affected by the corrosion may be fairly stable and not require immediate attention, meanwhile managing site drainage may have a larger impact and return on investment for the Cemetery overall.

Recommendations

Implement Preventive Conservation measures, especially pertaining to sustainable and environmentally friendly solutions for short and long-term preservation.

Develop and implement policies and specifications for low water use in irrigation systems, weed control and pesticides, pruning, mowing, and weed whacker use, and new plantings.

Document location, label and remove broken or loose headstones and footstones, loose tiles, or other elements that are at risk of theft because they can be picked up and removed from the Cemetery. Store in a safe indoor location until repairs can be made in accordance with current best practices.

B. Documentation

One of the best methods for involving volunteers is to conduct training and have them assist in developing a plot by plot conditions assessment of the Historic City Cemetery. Not only will this develop a baseline of documentation, but it will also help educate and focus volunteers on condition and preservation concerns.

All conditions, maintenance and treatments, any changes to historic features, needs to be documented. All cleaning, maintenance and repairs need to be pre-approved by a qualified professional with final inspections and approvals upon completion.

Recommendations

Consult with a conservator and historic landscape architect in developing, supervising, and assessing past and future surveys.

- *Survey form to include a page to sketch a plan of features and vegetation locations within each plot.*
- *Survey to include photographic documentation at 8 cardinal points from ground.*
- *Combine future survey results into the existing GIS database.*

Develop archive files for all condition and treatment documentation.

- *Documentation can be linked to a collections management database.*

- *Consult a collections manager and conservator for current documentation best practices.*

C. Maintenance

For the purposes of this report, the term “maintenance” is used to designate daily, weekly, monthly, or annual routine activities to maintain the Cemetery site. This typically includes horticultural activities such as irrigation, clearing loose debris, mowing lawns, pruning shrubbery trimming trees, and rinsing (with water only) historic paving, walls, monuments, or structures.

Excluded from maintenance and addressed under the section on “Treatment” are activities that include cleaning (other than water) historic elements, repair and/or replacement of historic features, adding or changing vegetation.

1. History

Maintenance has been provided by a combination of City staff and volunteers as noted in the Operations Assessment Study.

“A Sheriff’s crew is at the site each weekend to perform regular tasks such as weeding and mowing. The Sheriff’s crew consists of 50-120 people who come to the Cemetery every Saturday and Sunday. They are supervised and closely monitored by several Sheriff’s deputies, while City staff direct the work tasks. City staff divide the Sheriff’s work crew into smaller task-based crews; one group mows the Cemetery, another trims the pathways, and a more experienced crew does maintenance within the plots. This use of the Sheriff’s crews is based on an agreement between the City and the County and could be subject to change in the future.”^{xxix}

Volunteers conduct various maintenance activities that are not performed by the Sheriff work crew or City staff, mostly within family plots. There has been perceived custodial ownership of some of the historic plots by volunteers. Some areas of the Cemetery are overlooked.

“Due to the historic designation of the site and the inability to encroach on volunteers’ plots, the maintenance crew is often limited in what they can do. As a result, areas where volunteers have not been consistently present are often unattended and many structural issues at the site are left uncorrected for long periods.”^{xxx}

Recommendations

Given that the Cemetery is owned by the City, it is the Cemetery Manager’s prerogative to set all maintenance schedules and assign all maintenance tasks, whether it be to staff or any volunteers.

Establish a standardized work order process for all non-recurring tasks at the Cemetery.

Cemetery Manager to designate schedules for supervised volunteer work parties. Just as the work crew program is supervised by the Sherriff’s staff, all other volunteer activities are to be pre-scheduled and supervised by a qualified individual.

In all designated historic areas, the regular maintenance plan and schedule for recurring tasks should be developed by City preservation staff in consultation with a conservator. Non-standardized and non-recurring tasks also to be reviewed by a conservator.

Conservator should identify tasks that can only be carried out by qualified individuals.

Conservator should review horticultural guidelines for compliance with preservation best practices. A Historic Landscape Architect should review horticultural guidelines to determine appropriate plant species and consult with conservator regarding plant placement to minimize impacts to historic features.

Volunteers to perform tasks as designated by Cemetery Manager as outlined in individual volunteer assignment forms.

2. Horticulture

Overgrown trees and shrubs and plants can damage monuments, grave markers, walls, fencing, and other historic features. Overgrown roots push out historic features and dislodge masonry or fencing, cause permanent cracks to form, and can even encapsulate historic masonry. Root growth can dislodge, crack or break paving and foundations, in addition to causing trip hazards. Mature trees may fall during storms and drop large limbs that can damage or topple grave markers and mangle fencing. Continual watering and/or overgrown vegetation create wet, shaded areas and fosters biological growth that can accelerate deterioration of stone, iron, and wood objects. Vegetation attracts birds that can leave nitrate containing acidic droppings on the historic fabric, etching away the surfaces. Similarly, tree sap and other vegetal debris can accelerate deterioration by the acidic or other chemical components that come in contact with the surfaces.

Horticultural guidelines were updated by a sub-committee of the Technical Advisory Committee.

The following topics were not addressed:

- Policy on weed control and pesticides
- Mowing guidelines/weed whackers
- Plant rotations to contain root size

Recommendations

Retain a conservator and historic landscape architect experienced with historic cemeteries to develop a survey form. Work with volunteers to identify existing plant material at the plot level.

Historic landscape architect to develop policies on permissible plant species and identify plants to be preserved, added or removed.

Develop and implement policies and specifications for low water use in irrigation systems, weed control and pesticides, pruning, mowing and weed whacker use, and plant restrictions.

Where appropriate, consider moving roses that are impacting the historically significant features to the perimeter fence.

No changes to horticulture (removals, relocations, or additions) are to take place within any of the designated historic cemetery areas without prior approval of the Cemetery Manager. This includes any changes to existing plants as well as adding new plants. All maintenance tasks, including regular irrigation and pruning, are to be pre-approved by the Cemetery Manager. The Cemetery Manager is to consult regularly with a qualified historic landscape architect and a conservator as needed to ensure that all horticultural activity is within appropriate guidelines for the historic site and is not contributing to any damages of original historically significant features.

Based on its proximity, vegetation roots have the potential to damage historically significant features. Vegetation is to be selected and placed with future expected growth in mind. In keeping with preservation best practices, the Cemetery Manager in consultation with an historic landscape architect and horticulturalist are to pre-approve all new plantings and have the authority to remove any non-historic vegetation that is deemed too close to historic features (buildings, walls, fences, monuments and headstones) and may cause dislocation, deterioration or any other harm in the near future.

3. Irrigation



Irrigation is one of the main areas where the Cemetery can achieve greater sustainability and simultaneously comply with preservation goals. The Operations Assessment Study noted:

“A backflow and booster pump sits near the front of the cemetery and various irrigation heads are placed on fixed risers throughout the cemetery... There is a lack of adequate storm drainage facilities in the cemetery, and ponding and flooding sometimes occur.”^{xxxii}

There have been ongoing concerns regarding the impact of irrigation systems on the preservation historically significant features. Excess moisture is contributing to deterioration of the historic features. Volunteers and plot owners have access to water and run hoses to various plots to water plants. Water is often left on for long periods of time, flooding the area, sometimes on a daily basis.

Above ground sprinklers and sprayers contribute to excess moisture on the historic features, and unnecessarily wastewater. The location of several sprinkler heads are within inches of historic features, further contributing to deterioration by introducing excessive moisture.^{xxxiii}

Recent California droughts have threatened the Sacramento delta region and has required water rationing that will likely continue on an intermittent basis into the future. Since 2007, California has undergone yet another water shortage. The Sacramento area has active water saving initiatives.

The Cemetery Manager and City are considering installing a drip or bubbling irrigation system.

Recommendations

Install a water-efficient irrigation system following criteria as outlined in the 2007 Master Plan.

Any upgrades to irrigation should comply with maximum water saving best practices.

Install low water drip or bubbler system to reduce water usage.

Limit watering. Use automatic timers for limited water usage. Control water availability at sources using timers that are locked so that water may not be accessed.

Replace the grass in the walkways and plots with decomposed granite, using mulch on the plots.

Limit non-original plantings to drought tolerant species. An historic landscape architect should be further consulted on permissible drought tolerant species appropriate for the cemetery site.

D. Treatment

“Treatment” is the general term used by professionals for the cleaning, stabilization, repair and/or partial replacements for historic materials. While “maintenance” occurs on an ongoing basis and addresses many preventive needs, “treatment” generally occurs on an as needed basis, for example when buildings, walls, monuments or grave markers are vandalized with graffiti, are deteriorating, tumbling, broken, or have parts missing.

Current best practices for preservation of historic features require training and oversight by qualified professionals; City preservation and senior park maintenance staff working in consultation with an historian, historic landscape architect, horticultural specialist, conservator, and sometimes an archeologist and historic architect.

Treatment decisions require examination by a qualified conservator who understands the causes of the deterioration, the chemical and physical properties of the item to be treated, and the chemical and physical properties of the materials and methods prescribed to conduct the treatment. Treatment designs may vary depending on specific conditions and contexts. For this reason, it would be inappropriate to merely provide “recipes” for how to “treat” or repair broken features without having them first examined by a professional conservator who then can prescribe an appropriate treatment. Furthermore, the treatment should be supervised by the professional conservator.

As there is yet no certification for conservators, all treatments should be prescribed and overseen by a peer reviewed Professional Associate or Fellow member of the American Institute for Conservation (AIC), who have signed a pledge to abide by the AIC *Code of Ethics* and *Guidelines for Practice*. Definitions of a Conservator are available on the AIC website.^{xxxiii}

As clearly defined in the 2007 Master Plan, “Future changes in the cemetery should respect the historic character and should comply with the *Secretary’s Standards for the Treatment of Historic Properties with Guidelines for the Treatment of Cultural Landscapes*. The guidelines include standards for preservation, rehabilitation, restoration, and reconstruction.”^{xxxiv}

1. History of Treatments

Historic architects have been consulted in the past for repairs to the mausoleums. Current best practices have yet to be put in place for the smaller historic features such as monuments, markers, walls, and fences. There is limited documentation available on the history of maintenance and treatments. In the past, volunteers and maintenance crews have removed graffiti, mended broken headstones, and conducted cleaning of historic features. Work crews supervised by the Sheriff's Office have repaired masonry such as rebuilding brick retaining walls. Conservators have not been consulted on materials and methods for historic brick or masonry repairs.

Monument repair is currently funded by the OCCC.

In 2012 the City Historian implemented a system for repair requests. This minimum requirement only documents the need for repair on the basis of a brief narrative description of the issue, mapping, and photographic documentation and review and sign-off by City preservation staff. The volunteer group OCCC that funds many of the repairs proceeds with contracting the repairs without any further formalized oversight from City or other designated preservation professionals. There are no systems in place for conservation review of treatment or repair proposals, no conservation oversight, no documentation noting materials and methods used in accordance with the AIC *Code of Ethics* and *Guidelines for Practice*, and no final review or sign off by a conservator.

Many of the repairs for historic features are conducted by the cemetery monument business, Ruhkala Monument Co. Inc., located across the street from the cemetery entrance. The company has third generation experience in manufacturing and repairing cemetery monuments. They do not provide any brickwork or brick repairs. No documentation is provided on the methods or materials for repairs. The contractor is paid directly by the OCCC upon completion without any professional review or requirements for designated historic features.

Repairs are not necessarily done to current conservation best practices. City staff reviews work orders. Completed work is reviewed by designated city staff; however, there are no required final inspections or requirements for final documentation submittals.

The cleaning, maintenance, and repair of smaller historic features such as headstones, walls, fences and monuments often have more complexities than larger architectural features such as the mausoleums. There is a large body of conservation literature on each material of which the historic features are made: stone, metal, wood, mortars, as well as agents used for cleaning, consolidating and treatment. The City is advised to utilize the ongoing services of a conservator to help determine current best practices as the Cemetery works through preventive maintenance and repairs.

The City currently does not have in-house expertise on conservation for review of proposed or completed prescriptive materials and methodologies used for historic preservation best practices. A maintenance manual has been requested; however, it is difficult to standardize many of the treatments that may have several variables in determining appropriate solutions. For example, specifying an appropriate mortar for repointing or setting headstones will depend on not only the specific stone, but its current condition. See discussion in the appended Preservation Brief #2: Repointing Mortar Joints in Historic Masonry Buildings.

It would be more compliant with preservation best practices to put into place a conservator on retainer as part of a review and sign-off process, in addition to providing some training and supervision.

Recommendations

A qualified conservator should review policies and procedures, treatment proposals, and final completed treatments and repairs; help train staff and volunteers through regular workshops and oversee maintenance and repairs during scheduled volunteer work parties and contractor repairs of cemetery monuments.

All cleaning and repairs of historic features including wood, stone and metals from small markers to larger structures are to be done with pre-approvals and oversight of a qualified conservation professional, regardless of who is conducting the work.

All City staff and volunteers should follow best practices for a designated historic site, specifically following the Secretary of Interior Standards for the Treatment of Historic Properties and the American Institute for Conservation Code of Ethics and Guidelines for Practice that outline requirements for documentation of condition and treatment for historic features.

Provide basic preservation training for staff, volunteers, contracted services, prior to conducting any work on site.

No volunteer group or family is to undertake any repairs within any of the historic areas of the Cemetery without appropriate approvals and oversight. The Cemetery Manager is to manage all repairs and consult with historic professionals for appropriate repair materials and methods. All estimates or proposals for repairs are to be reviewed by the Cemetery Manager and a qualified conservator.

The City is to be the only entity contracting for maintenance and repairs of monuments and other historic features.. All maintenance and repair contractors are to meet City requirements including site safety and professionally approved scopes of work.

IV. Current Conditions

Many of the conditions remain unchanged since the assessment completed for the 2007 Master Plan.

Updates since 2007 include the following:

- ✓ Mortuary Chapel that previously housed cemetery records have been moved to The Center for Sacramento History, the City's official repository for historic records.
- ✓ The office at the front entry is now occupied by the new Cemetery Manager.
- ✓ The Cemetery Chapel is now a museum as per the 2007 Cemetery Master Plan.

Conditions noted in this Update report are based on type and are not quantified. Prioritized recommendations are in the appended List of Recommendations.

A. Vegetation



Overgrown shrubbery with roots too close to walls that push out walls. Overgrown branches hide grave markers that cannot be found or read.

Recommendations

See Recommendations under Section III. C. 2. Horticulture.

1. Trees



Some trees, such as older elms are contributing historic features. As they have grown, the root systems have pushed out masonry walls. Non-historic trees close with root systems pushing out walls. Trees in center of plots, away from historic features. Some trees flank monuments and are encroaching on them.

Tree removal will depend on several factors such as: whether it is historic (from the time period of 1849 to 1957); whether it is in decline and a potential public safety risk; whether it is currently impacting historic features such as pushing out walls or damaging monuments, or is likely to do so in the near future.

For the larger historic elms, it may be more practical to just repair dislodged brick masonry every ten years or so as the tree grows, until such time as the tree is removed or replaced. At that time the brick masonry wall can be reconstructed. This is more difficult to do for granite capped walls so decisions should be made with a team of professionals.

Recommendations

Repair walls as needed. Consider replacing historic trees in kind as they age out or decline.

Remove non-historic trees.

Consult with historic landscape architect, archaeologist, and families for tree removal and when it is appropriate to replace and with what tree species.

2. Trellises



Trellises are not historic features. Trellises spanning across more than one family plot need to have permission from the plot owners. The bases of the trellises are often too close to the historic wall features and can push the walls out.

Recommendations

Remove trellises. Relocate existing rose and other bushes to areas where the plants will not impact historically significant features.

B. Drainage



Drainage is paramount to preservation. Plots with soils sloped or lower than surrounding walls must have sufficient drainage away from historic features, including the walls themselves. Drainage systems were often built into historic features but may have since become clogged or dysfunctional over time and soils may have shifted, especially with decaying burials or coffins. Horticultural activities may have also changed soil levels and slopes over time. Water seeping through cracks in masonry walls have contributed to wear, surface spalling, dislocation of brick and stone.

Down pipes from building roofs that drain directly at the base of the structure are likely to cause foundation settling with weakened and moist soils. Ground slopes should be away from building walls and historic features.

Recommendations

Document drainage issues during the plot level survey.

Rectify drainage issues in consultation with the conservator. In some cases, this may involve moving top soils to adjust grades, and adding weeps to walls.

C. Structures

Historic structures include the Chapel and Mausoleums. General recommendations are noted in the 2007 Master Plan.



One of the mausoleums was called out during the site tour as needing more immediate attention as it has water intrusion issues and the interior cement ceiling may be unstable.

Recommendations

Conduct full assessments of the structures and work with an architectural conservator on stabilization.

a) Tile



Ceramic tile used as exterior paving on a mausoleum shows some signs of deterioration.

Recommendations

Clean with water only. Use a soft brush and sponge to clean up excess water.

Consult with a conservator to ensure adequate drainage or weeps, to re-grout, and repair.

D. Paving

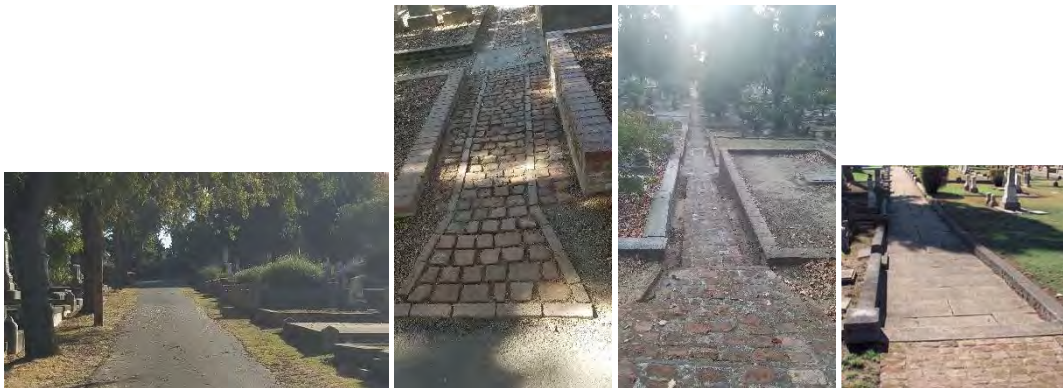

Some paving has become uneven over time.

Recommendations

Determine and document historic and non-historic paving. Remove non-historic uneven paving and replace with decomposed granite (DG) or other appropriate surface treatment.

Use landscaper cloth under mulch, DG, gravel to deter weed growth and to demarcate recent ground disturbances: below landscaper cloth means that the soils were not recently disturbed.

Repair uneven historic paving.

E. Walls



Several of the plot walls have dislocated brick, stone, and/or concrete. Some of the brick has been repaired in the past with the Sheriff's work crews. Materials and methods are unknown. Some of the previous repairs may have mortars that are too dense. Brick patterns do not always match previous existing.

Recommendation

Provide training and supervision by a conservator for wall repairs.

F. Monuments and Markers





General conditions for monuments are also noted in the 2007 Master Plan. Current conditions include broken, loose, or dissociated headstones or footstones that are susceptible to theft. Marble laying on the ground increases the rate of deterioration. Some ground markers are sunken below soil level, which also contributes to deterioration. Some headstone markers have been previously broken off and are set against or between base stones, while others are merely tilted. Some of the stone and cement grave coverings are cracked or broken. This further exacerbates drainage issues.

Previous repair techniques have included setting broken fragments in concrete, or pinning with various short dowels, neither of which are considered best practices today.

There is minor soiling and biological growth on some of the monuments and markers. Cleaning, other than rinsing with water to remove loose dirt and bird droppings, is not a high priority.

Recommendations

Document locations with photography and measurements of loose, broken, or dissociated headstones and footstones. Label each piece and store in a secure indoor location.

Retain a consulting conservator to work with the Cemetery Manager in developing prioritized cleaning and repair projects. Provide training workshops and conservator oversight for volunteer work parties for designated projects.

Consult with the conservator on all cleaning and repairs, regardless of who is conducting them.

Where potentially historic trees have disrupted brick walls, consult with an historic landscape architect. It may be preferable to repair sections of the brick every ten years or so, rather than to remove a tree.

G. Fences



Historic iron fences show minor corrosion. Some have missing parts.

Recommendations

Consult with a conservator for training and supervision to repair fences.

H. Education and Training

More than any other method, education and training for staff and volunteers will help with preservation efforts.

Recommendations

Provide training workshops from a qualified conservator with supervised field experience for the following

- *Documentation*
- *Maintenance tasks*
- *Supervised and phased cleaning and/or treatment campaigns*

IV. References

A Glossary of Historic Masonry Deterioration Problems and Preservation Treatments. Anne E. Grimmer. 1984, reprinted.

A Graveyard Preservation Primer (American Association for State and Local History) by Lynette Strangstad. 2013.

Association of gravestone studies website at <https://gravestonestudies.org>.

Best Practice Recommendations for Cleaning Government Issued Headstones. Mary F. Striegel, 2011.

Cemetery Documentation, National Center for Preservation Technology and Training (NCPTT). A webinar at <https://www.ncptt.nps.gov/blog/documentation>. Provides sample cemetery assessment and survey forms.

Eight Tips for Re-setting Headstones, National Trust for Historic Preservation, April 20, 2016, at <https://savingplaces.org/stories/eight-tips-for-re-setting-headstones#.XhY6nkBFw2w>.

Greenwood Cemetery website at <https://www.green-wood.com>.

How to Protect and Preserve Historic Cemeteries, Written by Jennifer Mueller, JD , Updated: August 29, 2019. Includes: Registering Historical Cemeteries, Surveying and Documenting Historical Cemeteries, Managing and Maintaining Historical Cemeteries, Cleaning and Repairing Markers, at <https://www.wikihow.com/Protect-and-Preserve-Historic-Cemeteries>.

How to Preserve Historic Cemeteries and Burial Grounds National Trust for Historic Preservation, December 22, 2015 at <https://savingplaces.org/stories/how-to-preserve-historic-cemeteries-and-burial-grounds#.XhY40UBFw2w>.

How to Preserve a Historic Cemetery, Arkansas Historic Preservation Program at <http://www.arkansaspreservation.com/Preservation-Services/how-to-preserve-a-historic-cemetery>.

Matero, Frank G. and Judy Peters. "Survey Methodology for the Preservation of Historic Burial Grounds and Cemeteries." In APT Bulletin, Vol. 34, No. 2/3 (2003), pp. 37-45.

Preservation Brief 2: Repointing Mortar Joints in Historic Masonry Buildings. Robert C. Mack, FAIA, and John P. Speweik. 1998.

Preservation Brief 38: Removing Graffiti from Historic Masonry. Martin E. Weaver. 1995.

Preservation Brief 40: Preserving Historic Ceramic Tile Floors. Anne E. Grimmer and Kimberly A. Konrad

Preservation Brief 48: Preserving Grave Markers in Historic Cemeteries Mary F. Striegel, Frances Gale, Jason Church, & Debbie Dietrich-Smith.

Also see several other online resources including video's when searching for "how to preserve historic cemeteries".

-
- ⁱ Sacramento Historic City Cemetery Assessment and Operations (SHCCAO) by RHAA Landscape Architects and L.F. Sloane Consulting Group, dated May 2019, p 20.
- ⁱⁱ Sacramento Historic City Cemetery Master Plan, Final December 2007, prepared by Royston Hanamoto Alley & Abey Landscape Architects and Planners, with Architectural Resources Group Architectural Conservation and BKF Engineers, Civil Engineers.
- ⁱⁱⁱ Operations Assessment Study.
- ^{iv} SHCCAO p 20.
- ^v SHCCAO p 20.
- ^{vi} SHCCAO p 20.
- ^{vii} SHCCAO.
- ^{viii} Sacramento Historic City Cemetery Assessment and Operations (SHCCAO) by RHAA Landscape Architects and L.F. Sloane Consulting Group, dated May 2019, p 18.
- ^{ix} SHCCAO p. 18.
- ^x 2007 Master Plan p. 61.
- ^{xi} SHCCAO p. 62.
- ^{xii} SHCCAO p. 15.
- ^{xiii} 2007 Master Plan pp 25-26.
- ^{xiv} 2007 Master Plan p. 24 and Sacramento Bee, February 7, 1860.
- ^{xv} 2007 Master Plan p. 24 and Sacramento Union, June 22, 1872.
- ^{xvi} 2007 Master Plan p. 24 and Hamilton Square area (circa 1938). (Sacramento Archives and Museum Collection Center, 1986/075/0261 Florence Henderson Collection)
- ^{xvii} 2007 Master Plan p. 36.
- ^{xviii} 2007 Master Plan p. 18.
- ^{xix} 2007 Master Plan p. 34.
- ^{xx} Ibid p 2.
- ^{xxi} 2007 Master Plan p. 36.
- ^{xxii} SHCCAO p 21.
- ^{xxiii} 2007 Master Plan p 29
- ^{xxiv} 2007 Master Plan, p. 36 and 29.
- ^{xxv} 2007 Master Plan p. 29.
- ^{xxvi} 2007 Master Plan p. 8.
- ^{xxvii} 2016 ArcGIS City Cemetery Drone Aerial, City of Sacramento.
- ^{xxviii} Wikipedia, https://en.wikipedia.org/wiki/Sacramento_Historic_City_Cemetery, cited October 14, 2019
- ^{xxix} Royston Hanamoto Alley & Abey, Sacramento Historic Cemetery Master Plan Final December 2007. p 2.
- ^{xxx} 2007 Master Plan p. 37.
- ^{xxxi} SHCCAO p. 13.
- ^{xxxii} SHCCAO p. 13.
- ^{xxxiii} 2007 Master Plan p 32.
- ^{xxxiv} See "Risk Factors" in Appended Preservation Brief 48: Preserving Grave Markers in Historic Cemeteries Mary F. Striegel, Frances Gale, Jason Church, & Debbie Dietrich-Smith, p. 5.
- ^{xxxv} Defining the Conservator: Essential Competencies, <https://www.culturalheritage.org/docs/default-source/administration/governance/defining-the-conservator-essential-competencies.pdf?sfvrsn=8> cited on December 3, 2019.
- ^{xxxvi} 2007 Master Plan p. 37.

Appendix A:
5-Year Preservation Plan

	Recommendations	Priority	Year 1	Year 2	Year 3	Year 4	Year 5	Task Status
1.00	Mission and Vision							
1.00	Clarify mission, vision and aesthetic horticultural goals for the historic cemetery with input from a historic landscape architect experienced with historic cemeteries based on available historic documentation.	1						
1.10	Consider moving roses that are impacting the historically significant features to other locations such as the perimeter fence.	1						
1.20	Update Website and Wikipedia descriptions to better reflect mission, vision and historic aspects of the Cemetery.	1						
2.00	Policies							
2.10	The City, as owner and primary steward of the Cemetery, must take steps to mitigate the risks of damage to the original significant historic features. The City must be in compliance with current best practices for preservation.	1						
2.20	Incorporate these standards and codes into City Ordinance 2002-020 (especially section 12.68.070 Maintenance by City Cemetery Staff), the Cemetery Manager’s Job Description, the Youth, Parks, & Community Enrichment Department (YPCE), all other City departments related to the cemetery, and all Bylaws of organizations contributing to maintenance and preservation of the cemetery.	1						
2.30	Historic landscape architect to develop policies on permissible plant species and identify plants to be preserved, added or removed.	1						
2.40	No changes to horticulture (removals, relocations, or additions) are to take place within any of the designated historic cemetery areas without prior approval of the Cemetery Manager. This includes any changes to existing plants as well as adding new plants. All maintenance tasks, including regular irrigation and pruning, are to be pre-approved by the Cemetery Manager. The Cemetery Manager is to consult regularly with a qualified historic landscape architect and a conservator as needed to ensure that all horticultural activity is within appropriate guidelines for the historic site and is not contributing to any damages of original historically significant features.	1						
2.50	In keeping with preservation best practices, no vegetation roots are to be near historically significant features. Vegetation is to be selected and placed with future expected growth in mind. The Cemetery Manager in consultation with an historic landscape architect and horticulturalist are to pre-approve all new plantings and have the authority to remove any non-historic vegetation that is deemed too close to historic features (buildings, walls, fences, monuments and headstones) and may cause dislocation, deterioration or any other harm in the near future.	1						
2.60	Conservator should review horticultural guidelines for compliance with preservation. An Historic Landscape Architect should review horticultural guidelines for appropriate species and consult with conservator regarding extent of easiveness on historic features.	1						
2.70	Decisions about any ground disturbances including moving, removing, replacing or adding plant materials, moving or shifting grave markers (even temporarily), requires approval of the Cemetery Manager and appropriate consultation with an archaeologist experience with cemeteries.	1						
2.80	In all designated historic areas, the regular maintenance plan and schedule for recurring tasks should be developed by City preservation staff in consultation with a conservator. Non-standardized and non-recurring tasks also to be reviewed by a conservator.	1						
2.90	Responsibilities for volunteers to follow tasks as designated by Cemetery Manager as outlined in individual volunteer assignment forms.	1						
2.10	Develop and implement policies and specifications for low water use in irrigation systems, weed control and pesticides, pruning, mowing and weed whacker use, new plantings and plant restrictions.	1						

	Recommendations	Priority	Year 1	Year 2	Year 3	Year 4	Year 5	Task Status
2.11	All City staff and volunteers should follow best practices for a designated historic site, specifically following the Secretary of Interior Standards for the Treatment of Historic Properties and the American Institute for Conservation Code of Ethics and Guidelines for Practice that outline requirements for documentation of condition and treatment for historic features.	1						
2.12	The City is to be the only entity contracting for maintenance and repairs of monuments and other historic features. All maintenance and repair contractors are to meet City requirements including site safety and professionally approved scopes of work.	1						
2.13	Conservator should identify tasks that can only be carried out by qualified individuals.	1						
2.14	A qualified conservator should review policies and procedures, treatment proposals, and final completed treatments and repairs; help train staff and volunteers through regular workshops, and oversee maintenance and repairs during scheduled volunteer work parties and contractor repairs of cemetery monuments.	1						
2.15	All cleaning and repairs of historic features including wood, stone and metals from small markers to larger structures are to be done with pre-approvals and oversight of a qualified conservation professional, regardless of who is conducting the work.	1						
2.16	No volunteer group or family is to undertake any repairs within any of the historic areas of the Cemetery without appropriate approvals and oversight. The Cemetery Manager is to manage all repairs and consult with historic professionals for appropriate repair materials and methods. All estimates or proposals for repairs are to be reviewed by the Cemetery Manager and a qualified conservator.	1						
2.17	Review current goals and tasks of City volunteer groups to ensure they are in line with the 2007 Master Plan and Updates, and the Operations Assessment Study.	1						
3.00	Organization and Management							
3.10	Given that the Cemetery is owned by the City, it is the Cemetery Manager’s prerogative to set all maintenance schedules and assign all maintenance tasks, whether it be to staff or any volunteers.	1						
3.20	Establish a standardized work order process for all non-recurring tasks at the Cemetery.	1						
3.30	Cemetery Manager to designate schedules for supervised volunteer work. Just as the work crew program is supervised by the Sherriff’s staff, all other volunteer activities are to be pre-scheduled and supervised by a qualified individual.	1						
3.40	Implement Preventive Conservation measures, especially pertaining to sustainable and environmentally friendly solutions for short and long-term preservation.	1						
3.50	Follow preservation priorities and integrate feasible and sustainable goals into Cemetery maintenance practices, including adopt-a-plot and all other programs which may involve work that could impact the significant historic features.	1						
3.60	Take further measures to mitigate non-approved and un-supervised volunteer activities that are not in alignment with historic preservation best practices and respect for the functionalities and context of a cemetery.	1						
4.00	Funding							
4.10	Seek funding sources for capital projects and maintenance of the cemetery Programming, Uses & Recreation.	2						
4.20	Consult with conservator for writing grants to repair historically significant features.	2						
5.00	Documentation							

	Recommendations	Priority	Year 1	Year 2	Year 3	Year 4	Year 5	Task Status
5.10	Document current locations and conditions of historic features and plant material. Research historic documentation of individual plots where information is missing. This can be done in conjunction with conservation and horticulture professionals working with volunteers, if needed. The Conservator and Horticulturalist can use the survey data to determine projected changes, maintenance, repairs or treatment to historic features and vegetation. Survey documentation can be uploaded to a cemetery-wide database. The City Historian can oversee a registrar familiar with collections management systems that can be utilized for retaining and updating documentation to include outcomes of the surveys, photographs, news clippings and other archival material. Digitize existing archival material to be retrievable in a multitude of ways (using data field search capabilities) such as by family plot name, plot numbers, plant material type, headstone or wall type, etc.	1						
5.20	Keep documentation up to date.	1						
5.30	Document family permissions for changes to any vegetation within family plots, other than normal pruning.	1						
5.40	Consult with a conservator and historic landscape architect in developing, supervising and assessing past and future surveys.	1						
5.41	- Survey forms to include a page to sketch a plan of features and vegetation locations within each plot.	1						
5.42	- Survey to include photographic documentation at 8 cardinal points from ground.	1						
5.43	- Determine and document historic and non-historic paving.	1						
5.44	- Document drainage issues impacting historically significant features.	1						
5.45	- Document location with photography and measurements of loose, broken, or dissociated headstones and footstones.	1						
5.46	- Combine future survey results into the existing GIS database.	1						
5.50	Develop archive files for all condition and treatment documentation.	1						
5.51	- Documentation can be linked to a collections management database.	1						
5.52	- Consult a collections manager and conservator for current documentation best practices.	1						
5.60	Use the survey and research data to develop a plant maintenance protocol with the input of the historic landscape architect and conservator.	1						
5.70	To enhance and promulgate historic preservation of the Cemetery, consider making appropriate portions of the archives accessible on a web-based platform to the public. Consider including condition histories and documentation generated by the survey.	1						
5.80	Label and remove broken or loose headstones and footstones, loose tiles, or other elements that are at risk of theft. Store in a safe indoor location until repairs can be made in accordance with current best practices.	1						
6.00	Drainage							
6.10	Document drainage issues impacting historically significant features as part of a plot level survey.	2						
6.20	Rectify drainage issues in consultation with the conservator. In some cases this may involve moving top soils to adjust grades, and adding weeps to walls.	2						
6.30	Remove non-historic uneven paving and replace with decomposed granite (DG) or other appropriate surface treatment.	2						
6.40	Use landscaper cloth under mulch, DG and gravel to deter weed growth and to demarcate recent ground disturbances. Soils below landscaper cloth means that the ground was not recently disturbed.	2						
7.00	Irrigation							
	Install a water-efficient irrigation system following criteria as outlined in the 2007 Master Plan.	2						
7.10	Any upgrades to irrigation should comply with maximum water saving best practices.	2						

	Recommendations	Priority	Year 1	Year 2	Year 3	Year 4	Year 5	Task Status
7.20	Install low water drip or bubbler system to reduce water usage.	2						
7.30	Limit watering. Use automatic timers for limited water usage. Control water availability at sources using timers that are locked so that water may not be accessed.	2						
8.00 Horticulture								
8.10	Remove non-historic vegetation that is impeding (obstructing or potentially damaging) on historically significant features (i.e., monuments, markers, walls, and fencing).	2						
8.20	Prune vegetation that remains from period of significance (prior to 1957 that shows in 1953 aerial photo) to prevent intrusion on historically significant features.	2						
8.30	In some cases, historic vegetation that has been lost or is in decline, namely the elm trees, can be replaced in kind if the new trees are planted in locations that do not impinge on historically significant features, including future root growth impinging on historic features.	3						
8.40	Replace the grass in the walkways and plots with decomposed granite, using mulch on the plots.	2						
8.50	Limit non-original plantings to drought tolerant species. An historic landscape architect should be further consulted on permissible drought tolerant species appropriate for the cemetery site.	2						
8.60	Consult with historic landscape architect, archaeologist and families for tree removal and when it is appropriate to replace and with what tree species.	2						
8.70	Remove trellises. Relocate existing rose and other bushes to areas where the plants will not impact historically significant features.	2						
8.80	Where potentially historic trees have disrupted brick walls, consult with an historic landscape architect. It may be preferable to repair sections of the brick every ten years or so, rather than to remove a tree.	2						
9.00 Education and Training								
9.10	Provide basic preservation training for staff, volunteers and contracted services prior to conducting any work on site.	1						
9.20	Provide training workshops from a qualified conservator with supervised field experience for the following:	1						
9.21	- Documentation	1						
9.22	- Maintenance tasks	1						
9.23	- Supervised and phased cleaning and/or treatment campaigns	2						
10.00 Treatment of Historically Significant Features								
10.10	Retain a consulting conservator to work with the Cemetery Manager in developing prioritized cleaning and repair projects. Provide training workshops and conservator oversight for designated projects. Consult with the conservator on all cleaning and repairs, regardless of who is conducting them.	2						
10.20	Conduct full assessments of the structures and work with an architectural conservator on stabilization.	2						
10.30	Provide training and supervision by a conservator for repairs of walls, fences, tilework, historic paving, and any historically significant features.	3						
10.40	Consult with a conservator to ensure adequate drainage or weeps, to re-grout, and repair.	3						
10.50	Clean masonry with water only. Use a soft brush and sponge to clean up excess water. Consult with a conservator on a case-by-case basis for all other cleaning, repairs, or use of any materials other than water.	3						

Appendix B:
Reference Materials

48 PRESERVATION BRIEFS

Preserving Grave Markers in Historic Cemeteries

Mary F. Striegel, Frances Gale, Jason Church, & Debbie Dietrich-Smith



National Park Service
U.S. Department of the Interior
Technical Preservation Services



Cemeteries found across the country are not only places of burial, but they also provide a vivid record of community history. Whether large or small, well maintained or neglected, historic cemeteries are an important part of our cultural landscape. The vast richness of expression through form, decoration and materials informs our understanding of the individuals buried in historic cemeteries and their cultural significance.

While cemeteries are often considered to be perpetual, their most prominent feature—the grave markers—are not. They weather, naturally decay, often are poorly maintained and repaired and, on occasion, are vandalized (Fig. 1). Grave markers are usually noteworthy not only for their inscriptions but also for their craftsmanship. Exceptional markers are considered works of art.

This Preservation Brief focuses on a single aspect of historic cemetery preservation—providing guidance for owners, property managers, administrators, in-house maintenance staff, volunteers, and others who



Figure 1. Sandstone and slate grave markers in the Ancient Burying Ground in New London, CT, display a variety of weathering conditions. Markers in the cemetery date from the mid-17th to the early 19th centuries. Photo: Jason Church.

are responsible for or are interested in preserving and protecting grave markers. Besides describing grave marker materials and the risk factors that contribute to their decay, the Brief provides guidance for assessing their conditions and discusses maintenance programs and various preservation treatments.

Also identified are a number of excellent references that address materials used in all grave markers, including several other Preservation Briefs (listed in Additional Reading). This Brief highlights particular issues that should be considered with historic grave markers.

Types of Traditional Grave Markers

The great variety in the types of grave markers is a fascinating aspect of the study and appreciation of historic cemeteries. Three broad categories can be used to describe grave markers—(1) single-element, (2) multiple-element, and (3) structures. Single-element grave markers are stone, cast iron, or wood elements that are set in a vertical position or placed as a horizontal slab on the ground (Fig. 2). Early examples of this simplest type of grave markers are field stone and basic wooden or wrought iron crosses, with the name of the deceased person scratched into or engraved on the marker. Often, these rudimentary grave markers are overlooked, significantly deteriorated, or lost. Vertical stone slabs and large stone ledgers laid horizontally over the gravesite are more sophisticated examples of this type.

Multiple-element grave markers are found in a number of different forms (Fig. 3). In the most typical form, a grave marker would consist of two stones—an upper headstone placed on top of a base stone. The upper headstone may be secured in a number of different ways to the base. In the simplest of forms, the upper stone was placed on the base, set in a bed of mortar on top of the base, or joined with pins and mortar. With a “tab-and-



Figure 2. These mid-19th century, single-element stone grave markers in the Grove Cemetery in Bath, NY, are set in a vertical position. Photo: Jason Church.

slot" grave marker, the tabbed upper stone was set in a slotted base. More common today, the upper headstone is secured with a technique that uses small spacers set on the base and a setting compound. This technique or one that uses an epoxy adhesive may be found on older markers where the stones have been reset.



Figure 3. A multi-element grave marker from the early 19th century in the St. Michael's Cemetery, Pensacola, FL, consists of a vertical element with tabs (left image) into a slotted base (right image). Photo: Fran Gale.

Stacked-base grave markers use multiple bases to increase the height of the monument and provide a stable foundation for upper elements. Tall, four-sided tapered monuments, known as obelisks, are typically placed on stacked bases. Columns or upright pillars have three main parts – a base, shaft, and capital. Multiple-element grave markers may also include figurative or sculptural components. Traditionally, stacked base grave markers were set on lead shims with mortar joints or with lead ribbon along the outer edges.

Grave markers can also be engineered structures. Examples of grave marker structures include masonry arches, box tombs, table tombs, grave shelters, and mausoleums (Fig. 4). The box tomb is a rectangular structure built over the gravesite. The human remains are not located in the box itself as some believe, but rather in the ground beneath the box structure. The table tomb is constructed of a horizontal stone tablet



Figure 4. This sandstone table tomb, located in Cedar Grove Cemetery, New London, CT, is an engineered grave marker structure consisting of a horizontal stone tablet supported by four vertical table "legs" with and a central column,. Photo: Jason Church.

supported by small corner supports or columns. Grave shelters, also called grave houses, can be simple or elaborate wooden structures built over the gravesite. Mausoleums are above-ground buildings with compartments for multiple burials. Engineered structures also include hillside and underground tombs.

Guidelines for Evaluating and Registering Cemeteries and Burial Places, National Register Bulletin 41, provides a concise review of grave marker types.

Materials

Stone, brick, concrete, metal, and wood are the most common materials used for grave markers and for fences and gravesite enclosures in historic cemeteries. This section briefly describes the composition and properties of these diverse materials

Masonry materials

There is a wide variety of masonry materials used in historic cemeteries; some are naturally occurring and others man-made. Although there are notable exceptions, most masonry materials are durable, have high compressive strength, and are resistant to weathering. As grave markers, they typically represent the work of masons and stone carvers.

Stone is a naturally occurring material with a wide range of properties and is available in a variety of colors (Fig. 5). Geologists classify stone according to the way in which it was formed with the three categories being igneous, sedimentary and metamorphic rock. Stone found in cemeteries is predominantly quarried, though the use of field stones is not uncommon. The mineralogy and chemical composition of stones vary. Some are composed primarily of silicate minerals; granites, sandstones, slate, and schist are examples. Other stones contain calcium carbonate with marble and limestone in this group. Mineralogy, chemical composition, and physical structure of the stone influence weathering and



Figure 5. A variety of colors of natural stone are found in historic cemeteries, such as this pink granite marker in the Cedar Grove Cemetery, New London, CT. Photo: Jason Church.

the selection of materials and procedures for its cleaning and protection.

Man-made masonry materials are manufactured from naturally occurring raw materials. For example, the raw materials used to make brick include clay, sand, and shale. During firing, clay minerals and sand melt and come together forming silicates, aluminates, and metallic oxides. The resulting brick material has a hard-fired outer surface with a softer interior.

Concrete is a man-made material composed of cement, sand, gravel, and water. Most concrete produced after 1870 contains Portland cement, another manufactured product. In its plastic or wet state, concrete can be cast or poured. It hardens by hydration, a chemical-curing process. The resulting product has excellent compressive strength, but much lower tensile strength. Reinforcing concrete with steel helps compensate for this limitation.

All masonry materials are porous with an interior network of pores. The porosity of sedimentary rocks such as limestone and sandstone can be as high as 20 percent while the pore volume of granite is very low. Because moisture is a key factor in many deterioration processes, porous masonry materials are more vulnerable to weathering.

Metals

Metals are solid materials that are typically hard, malleable, fusible, ductile, and often shiny when new (Fig. 6). A metal alloy is a mixture or solid solution of two or more metals. Metals are easily worked and can be melted or fused, hammered into thin sheets, or drawn into wires. Different metals have varying physical



Figure 6. Decorative cast-iron grave markers like this late-19th century one in Oakland Cemetery in Shreveport, LA, are produced by heating the iron alloy and casting the liquid metal into a mold. Photo: Jason Church.

and mechanical properties, aesthetics, and weathering characteristics.

Ferrous metals and alloys, including cast iron, wrought iron, and steel, all contain iron. Cast iron also contains carbon and silicon and has a relatively low melting point. When heated to a liquid state, it can be molded into a variety of shapes. Wrought iron is an alloy with low carbon content. Its fibrous inclusions (called slag) are sometimes visible to the naked eye. Unlike cast iron, wrought iron is heated to the point where it becomes soft and then is hammered or “worked” into desired shapes. Most of the wrought and cast iron in historic cemeteries is ornamental rather than structural. While cast iron, steel, and wrought iron all contain iron, steel and wrought iron are more resistant to corrosion. Paint was often applied to ferrous metals to help protect them from corrosion and for decorative purposes. Metal elements were painted in a variety of colors including black, white, and green, among others.

Nonferrous metals and alloys, such as bronze, zinc, and lead, do not contain iron. Bronze contains about 85% copper, 10-15% tin, and sometimes lead. Historic bronze cemetery markers were created by casting processes that involves pouring liquid bronze into a mold. The completed casting is hollow. Bronze work may comprise a single molded component, such as a plaque, or multiple molded components welded or fitted together as with large statuary. Chemical patinas were applied to enhance color, and clear coatings for protection. Cast zinc monuments were popular from 1870 through the early 20th century. Most cast zinc is bluish-gray in color. Although cast zinc is resistant to corrosion, it is a brittle material with a tendency to “creep” or deform, especially when exposed to high outdoor temperatures.

Wood

Wood is a porous organic material composed of tubular cells in a parallel arrangement. The structure and characteristics of these cells determine the wood’s



Figure 7. As shown by this 1877 marker in Silver Terrace Cemetery, Virginia City, NV, exposure to sunlight can damage wood grave markers, making the wood more susceptible to water damage and cracking. Photo: Jason Church.

appearance and influence wood properties. Wood-cell walls and cavities contain moisture. Oven drying reduces the moisture content of wood. After the drying process, the wood continues to expand and contract with changes in moisture content. The loss of water from cell walls causes wood to shrink, sometimes distorting its original shape (Fig. 7).

Hardwoods come from deciduous trees such as oak, maple, and walnut; softwoods from conifers such as pine, cedar, and fir. In general, hardwoods have higher density than softwoods, which makes them more durable materials, and are darker in color. Wood cut at different orientations affects its strength and weathering. As an organic material, wood is also particularly vulnerable to termites, carpenter ants, and other wood-destroying insects and fungi. Paints, coatings, and fungicides such as borates are used to help protect wood from various insect damage and fungal rot.

Other materials

Old cemeteries often include a wide variety of other materials not normally associated with contemporary grave markers, such as ceramics, stained glass, shells, and plastics (Fig. 8). As with masonry, metals, and wood, each has its own chemical and physical properties which affect durability and weathering. These materials



Figure 8. A fired ceramic, this cameo is set in a marble grave marker, located in Elmwood Cemetery, Memphis, TN. Different materials may require different conservation approaches. Photo: Mary Striegel.

present unique challenges and their properties must be understood before establishing appropriate maintenance and repair. Documentation of unusual materials is critical when repair is not possible.

Weathering

All grave marker materials deteriorate when they are exposed to weathering such as sunlight, wind, rain, high and low temperatures, and atmospheric pollutants (Fig. 9). If a marker is composed of several materials, each may have a different weathering rate. Some weathering processes occur very quickly, and others gradually affect the condition of materials. Weathering results in deterioration in a variety of ways. For example, when exposed to rainwater some stones lose surface material while others form harder outer crusts that may detach from the surface.



Figure 9. The limestone and sandstone grave markers in this historic cemetery have different weathering processes. On the left, the limestone shows surface loss in areas exposed to rainwater and gypsum crust formation below. The sandstone marker on the right displays uniform soiling, but surface hardening may be occurring. Photo: Fran Gale.

Granite is a durable grave marker material considered resistant to weathering. It is a compact, hard rock with low porosity, and granite deterioration can be imperceptible for many years. Slate also has low porosity, but its layered structure can result in delamination. Some stones used to make grave markers, like sandstone, limestone and marble, are softer than granite and more porous. These materials are more vulnerable to weathering with deterioration noticeable during the initial years of exposure. With slate and other stones with layered structures, weathering sometimes results in delamination, defined as the separation of layers along bedding planes. Different rates of weathering are related to the chemical composition and physical structure of the material.

Deterioration affects other grave marker materials in different ways. With brick, durability is related to its firing temperature, which influences the brick's compressive strength and absorption. Brick fired at high temperatures has a protective fire skin. The weathering of concrete also is variable, and largely depends on the materials used in its manufacture. For example, Portland cement concrete is generally more resistant to weathering than lime concrete. With wood, grave markers fashioned from heartwood (the dead inner wood) are more durable than those of sapwood (the living exterior wood), and some wood species such as cedar, Osage orange and black locust contain extractives that provide decay resistance.

The term "inherent vice" is used to describe a material with a naturally occurring problem that leads to premature deterioration (Fig. 10). An example of this problem is marble that has cracked due to natural locked-in stresses. Inherent vice also describes grave markers that are composed of incompatible materials, where decay is accelerated in one or both materials because of chemical interactions caused by their close proximity. An example is the galvanic corrosion that occurs when dissimilar metals, such as copper and iron, are in contact and exposed to moisture.

Risk Factors

There are two major categories of risk factors that can impact historic grave markers. The first comprises naturally-occurring deterioration phenomena known as the forces of nature, including weathering. The list of natural risk factors includes climate, biological issues, and natural hazards such as fire and floods. The other category includes the many degradation phenomena that are related to human activities. The results of humans and their actions include pollution, lack of maintenance, inappropriate repairs, arson, and vandalism. While some of the factors related to human activities, such as improper repair, may not be intentional, the results can be just as damaging to grave markers.

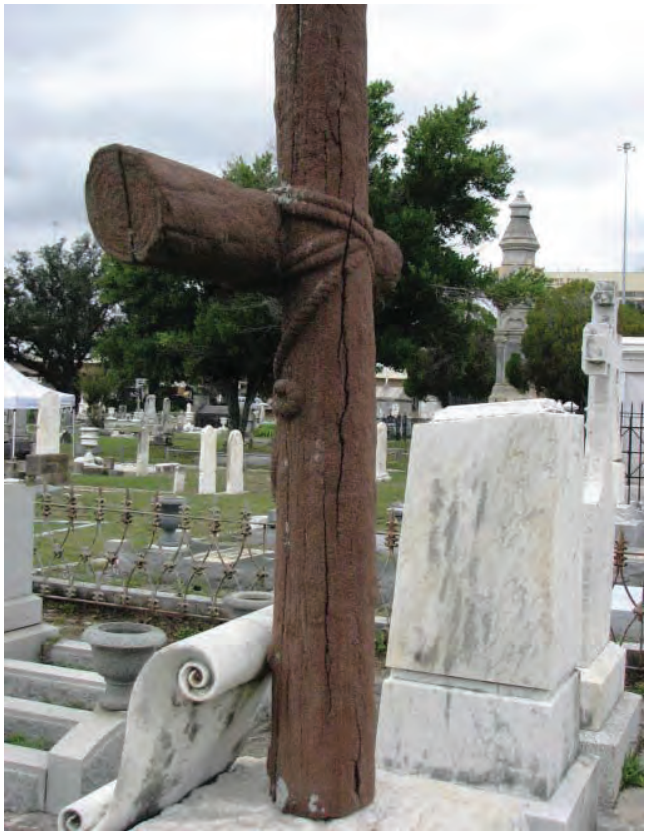

Figure 10. The sandstone cross (carved to look like wood) in this grave marker in St. Michael's Cemetery in Pensacola, FL, provides an example of inherent vice – the severe delamination affecting the sandstone has occurred along its natural bedding planes. Photo: Fran Gale.

Often, it is not possible to separate natural risk factors from those related to human activities. For example, pollution is deposited on grave markers by rain and other forms of precipitation, resulting in discoloration and often material degradation. Whether due to natural risk factors, human activities or both, "synergism" occurs when the result of two or more risk factors is greater than the sum of the individual effects. An example is the damage that occurs to salt-laden masonry materials during freeze/thaw cycles. The combined effect of these two deterioration factors is severe.

Natural Risk Factors

Climate plays an important role in weathering processes. Depending upon the climate, cemetery grave markers are exposed to rain, snow, sleet, ultraviolet (UV) light, humidity, high and low temperatures, and wind. All of these forces can damage masonry, metals, and wood. For example, with wood, the UV rays present in sunlight accelerate the weathering process.

Exposure to repeated changes in temperature can have an adverse effect on materials such as stone and other porous masonry. High temperatures deteriorate and weaken many materials while low temperatures cause materials to become brittle. In some climates there are rapid changes during spring and fall that



Figure A. Cemeteries are cultural landscapes made up of a variety of features. Grave markers are but one component of cemeteries that also include walkways, drives, fences, coping, trees, shrubs, and other vegetation. Each component adds to the understanding of the cemetery landscape. Photo: Debbie Dietrich Smith.

Vegetation Management

Carefully monitoring and managing of trees and other vegetation is an integral part of a cemetery preventive conservation program. Mature trees and ornamental shrubs can add character, shade, and seasonal color to historic cemeteries (Fig. A). However, if not properly maintained, they can damage grave markers, fencing, and other historic features. Mature trees may fall during storms and drop large limbs that topple grave markers and mangle fencing. Overgrown vegetation creates wet, shaded areas and fosters biological growth that can accelerate deterioration of stone, iron, and wood objects.

A treatment plan for cemetery vegetation should address trees, shrubs, vines, and “volunteer” growth. For the assessment and treatment of trees that pose hazards, consult an International Society of Arboriculture (ISA) certified arborist. Prune trees and shrubs adjacent to grave markers to allow air circulation and light penetration. Certified arborists and master gardeners should carry out this work or direct others in pruning trees and shrubs, as many may be historic features integral to the cultural landscape and worthy of preservation.

Regarding lawn care, historic cemeteries were not designed for today’s large riding lawnmowers, yet this is the mower of choice for many cemeteries, as mowing is one of the most time-consuming and costly maintenance tasks generally undertaken. Mowing between tight spots with a large riding mower deck is destined to cause damage. Best practices include using a smaller, push mower between particularly sensitive features, and outfitting riding mower decks with protective bumpers. Low-cost options include using fire hose padding or a foam swimming ‘noodle’ (Fig. B). Additional damage is caused by riding over low stones or coping, especially when the blade height is set low. If rolling over these features is unavoidable, many riding mowers have a hand-control adjustment to temporarily raise and lower the blade height.

Improper use of a string-trimmer is also potentially destructive, especially when it comes into contact with soft materials such as marble, limestone, and wood. Using the lightest trim line and angling the trimmer head towards the ground will help reduce damage if the trimmer hits unintended targets. Consider hand trimming around the most significant, fragile features.

As a time-saving measure, herbicides are sometimes used around the base of features to remove unwanted grass and weeds. In most cases, use of herbicides for this purpose is not recommended, as salts within the herbicide can wick into the stone (especially soft stones) and cause spalling and deterioration. The removal of vegetation also exposes soil around the base of the grave marker, which, in a heavy rain, can cause soil splashing that may result in staining.

If fertilizer is applied, choose a natural organic fertilizer to minimize salt content for the reasons stated above. For any chemical application, be sure to rinse away residue from grave markers, etc., with water using a low pressure hose or spray bottle, to minimize continued contact.

Ongoing maintenance of cemetery vegetation is essential to conserve grave markers and fencing. Periodic inspections may warrant removing trees; trimming tree limbs, shrubs, and vines; and removing volunteer vegetation. All trees should be inspected at least every five years. Annual inspections are necessary to assess the condition of shrubs and vines, and to identify volunteer growth for removal. Mowing and trimming around the hundreds of stone, brick, iron, and wood features found in many cemeteries is a weekly or bi-weekly chore. Lawn care is the most time-consuming, and, if not done carefully, potentially destructive maintenance activity in historic cemeteries.



Figure B. A pool ‘noodle’ can be fitted to the deck of a lawnmower to prevent damage to grave markers. Photo: Debbie Dietrich Smith.

cause damaging cycles of expansion and contraction. Adjacent dissimilar materials may respond differently to temperature changes, resulting in distortion. High winds can carry water and abrasive particles causing abrasion and erosion, especially to soft materials. Wind may also drive rain water into masonry joints and permeable elements and materials.

Water, in liquid, solid or vapor form, plays a critical role in the deterioration process. Most grave marker materials are porous, and moisture from precipitation, ground water, or frequent landscape watering can enter the pore system. If temperatures drop below the freezing point, water in interior pores, joints and cracks freezes, and its increased volume often applies internal pressure, resulting in damage to the grave marker such as cracks or spalling.

Ferrous metals are particularly vulnerable to water-related deterioration. Iron increases in size when it corrodes, sometimes as much as 20 percent. As the corrosion process proceeds, the ferrous metal eventually weakens. When embedded within concrete or masonry materials, the corroding iron often causes cracks and spalls in the masonry.

Woody vegetation can damage grave markers in a variety of ways (Fig. 11). Trees, bushes, and vines can shade grave markers, extending the time that the markers are exposed to moisture. Tendrils and roots may burrow into mortar joints and openings, causing mechanical damage and large plants may lift up or shift markers. Even leaves and twigs, when allowed to collect on the ground near grave markers, can affect water drainage and evaporation (Fig. 12).

Microorganisms such as algae, fungi, and lichens may affect grave markers. Microorganisms hold in moisture and some produce acids. With acid-sensitive materials such as limestone and marble, the result is surface erosion. Sometimes the organisms use the material as a food source, dissolving minerals in the stone and attacking the cellular structure of wood. Wood is especially vulnerable to fungi, algae, and other microorganisms when its moisture content is above 25%.

Infestation by termites, carpenter bees and ants, and other insects can affect the appearance and structural integrity of wood. Unsightly bird droppings can also affect paint and other surface finishes.

Human Activities

Aside from vandalism and purposeful neglect, most risk factors attributable to human activity are unintentional. Sometimes damage to grave markers is the result of cleaning or repair done with the best of intentions. These unfortunate mistakes can be the result of insufficient training and funding, misuse of tools and equipment, and poor planning. With proper training and supervision, human risk factors can be lessened.



Figure 11. Woody vegetation can damage grave markers and pose a risk to visitors unless well managed and maintained. Photo: Jason Church.

Deferred maintenance usually accelerates the deterioration of grave markers and can be a safety hazard. All materials have a service life with mortar, paints, and other coatings requiring periodic upkeep to be effective. For example, unless ferrous metal has a sound protective coating, exposure to weathering can result in corrosion. Loose, misaligned or detached grave markers may lead to further damage or deterioration if not corrected in a timely manner. When nearby trees and shrubs are overgrown and invasive vegetation is present, needless risks to historic grave markers may also occur.

Inappropriate maintenance activities can be devastating. One of the most common threats stems from improper lawn care, particularly the misuse of mowing equipment and string trimmers (weed whackers). The use of large mowers or mishandling them can lead to displacement of markers. Scrapes, gouges and even breakage also can occur. Improper use of string trimmers in areas immediately adjacent to grave markers can result in



Figure 12. A cemetery professional undertakes a tree inventory in American Cemetery, Natchitoches, LA, to determine the health of trees in the cemetery. Management decisions for trimming or removal are based on the inventory. Photo: Debbie Dietrich Smith.

Avoiding 10 Common Maintenance Mistakes

1. Maintain records on conditions and treatments of historic markers.
2. Seek advice from persons experienced with preserving historic markers when initiating a major maintenance or repair program.
3. Discourage visitor use of chalk, shaving cream, and other materials to highlight carvings and lettering.
4. Train grounds crews in methods to avoid damage to historic markers, including flat grave markers which can be easily damaged by machinery, fertilizers and weed killers.
5. Remove graffiti as quickly as possible, using appropriate methods, so as not to encourage further marker disfiguration and vandalism.
6. Maintain ground cover around cemetery markers to avoid surrounding dirt from splashing back and staining grave markers.
7. Never use rotary grinders to resurface or "clean" historic markers.
8. Avoid the use of coatings on masonry without proper investigation.
9. Avoid high pressure water washing to clean historic markers.
10. Repair rather than replace damaged and deteriorated grave markers. For markers encased in cement, leave any repair work to trained conservators.

Figure 13. The impervious coating used to "protect" this sandstone grave marker trapped moisture within the stone, eventually resulting in deterioration and surface loss. Photo: Fran Gale.



Figure 14. High-pressure water washing can damage grave markers. The photograph shows "wand marks" on the headstones produced by inappropriate pressure washing. Photo: Jason Church.



Harsh cleaning products and techniques can have a detrimental effect on grave markers. Acidic cleaners such as muriatic acid can dissolve minerals in many masonry materials and can attack metals. Alkaline cleaners, such as bleach, are notorious for leaving residual salts that are deposited on the surface (a process called efflorescence). Both acidic and alkaline cleaning can result in staining, especially if rinsing is inadequate. Using high-pressure water, above 500 to 1,000 psi, can needlessly damage materials as well, increasing their vulnerability to weathering (Fig. 14). If the marker is fragile, even low pressure water can be damaging. Techniques to avoid include aggregate blasting with sand or other harsh media and the use of power tools with abrasive wire or Nylox™ brushes.

Pollution

Grave markers can be both visually and materially affected by pollution. Most readily apparent is the discoloration that takes place when airborne pollutants are deposited on markers. Depending on the exposure, how water is shed, and the marker material and intricacies, discoloration on markers will usually appear uneven and in streaks.

scratching and even cutting into softer stone and wood. Generally, the use of chemical weed killers at the base of grave markers should be avoided, especially if there is a risk that the marker would absorb the chemicals.

Repointing masonry grave markers using Portland cement mortars that are harder than historic mortars often results in accelerated deterioration of the masonry material. Mortar should be softer than the adjacent masonry, enabling trapped moisture to migrate out, and serve as the sacrificial material when cracking occurs to relieve excessive stress. Problems also result when using impervious "protective" coatings that can trap moisture within the masonry, resulting in damage during wet/dry and freeze/thaw cycles (Fig. 13).

While the visual effect of pollution is often discoloration, less apparent is the potential damage caused by pollution to the grave marker materials themselves. Most rain is slightly acidic, and its pH (a measurement of acidity) becomes more acidic when pollutant gases, such as sulfur dioxide and nitrous oxides, are present. Acid rain damages materials containing calcium carbonate, such as limestone and marble, resulting in surface loss or erosion. When erosion is severe, the grave marker inscription, carvings and sculptural elements may become discernable. Recarving the inscription is not recommended. Instead, a small stand-alone interpretative sign could be placed nearby.

Acid rain also damages bronze grave markers. Pollutant gases alter the composition of exposed bronze, often producing water-soluble minerals. These minerals are washed away during subsequent rains, resulting in surface erosion. If the bronze element is positioned on a masonry pedestal or plinth, the minerals are deposited on the masonry below. These effects of acid rain are disfiguring to the bronze element and associated masonry.

Condition Assessments

Condition assessments help identify potential safety hazards, required preservation work, and any additional conservation that is needed for stabilization and protection of grave markers. Assessments also provide important baseline information about deterioration affecting grave markers. The collected information is helpful in determining and prioritizing maintenance tasks, identifying unstable conditions that pose an immediate threat, and for developing a plan for any needed repair or conservation work. Assessments should be recurring, preferably every spring. Condition assessments also help determine the extent and severity of damage following a disaster.



Figure 15a. Condition surveys are undertaken to document current conditions, determine safety issues, and plan both emergency stabilization and future treatment plans. There are a variety of survey forms available that can be tailored to the specific cemetery. Photo: Mary Striegel.

Depending upon the size of the cemetery and funding available, the initial assessment may be carried out by a team consisting of cemetery staff, a materials conservator, and, where necessary, an architect or structural engineer for cases involving large monuments and mausoleums (Figs. 15a and 15b). For smaller cemeteries without large monuments and mausoleums, and where funding is problematic, volunteers can be trained to prepare a condition assessment under the guidance of an experienced individual.

The first step in any condition assessment is to gather background information, including cemetery records and documents, historical photographs, records of previous repair and maintenance work, and current practices. The next step is to conduct an on-site survey. Following the survey, recommended maintenance procedures should be provided. If the team or individual conducting the survey is experienced in repairing historic grave markers, their assessment should include information about appropriate materials and techniques for restoration and stabilization.

Survey forms facilitate both recording of field conditions and needed maintenance or repair work. Most forms include sections for marker type (headstone, obelisk, etc.), construction materials, orientation, dimensions, soil type, and grave marker deterioration. There are a number of excellent examples of survey forms available for download, including the National Park Service Condition Survey Form at www.ncptt.nps.gov. However, because each cemetery is unique, it may be necessary to modify an existing form.

A tool kit for the condition assessment may include binoculars, digital camera, magnifying glass, measuring tape, clipboard, carpenter's rule, level, magnet, and flashlight. For large monuments, a ladder or aerial lift may be required. Photographs of each marker, including overall shots and close-up details, are an essential part of the documentation process. Photo logs are helpful for



Figure 15b. Photographs are used to document the condition of the grave marker as part of a condition assessment. Photo: Fran Gale.

recording the date, direction, and photographer. Digital photographs should be captured in a standardized size and format (.tif, .jpg, .raw).

Defining conditions can be challenging, especially for cemetery staff and volunteers who are new to the process. There are a number of illustrated glossaries that can assist with determining accurate terminology for describing conditions. The ICOMOS Illustrated Glossary on Stone Deterioration Patterns <http://www.international.icomos.org/> and the NACE International Resource Center Corrosion 101 <http://nace.org/> are excellent resources.

Where deterioration is apparent, the assessment should address questions such as:

- What are the physical characteristics of the defects? Has deterioration obscured ornamental work or made the inscription difficult to read?
- What is the extent of the affected area? Are all areas of the marker affected by deterioration or is there a pattern?
- Do the conditions appear to be stable or getting worse.
- Are the defects affecting other materials or impacting the safety of visitors?
- Is deterioration contributing to loss or theft?
- Is further investigation required?

Maintenance

The old axiom that an ounce of prevention is worth a pound of cure certainly applies to the preservation of historic cemeteries. Maintenance is essential to the long-term preservation of historic grave markers. The principal components of a maintenance program include regular inspections, cyclical and prioritized maintenance work, and annual reports and budgeting. An important first step is the development of a support team, including staff, conservators, engineers, skilled masons, and other professionals. In most cases, the cemetery manager should initiate this process.

The cemetery manager can use the information from the condition assessment report to develop a maintenance plan with a list of cyclical maintenance work. Many tasks can be carried out by in-house staff. For example, maintenance cleaning of metal and stonework can often be accomplished by rinsing with a garden hose. Applications of wax coatings can be used to protect bronze elements. Trained staff can undertake these tasks. Teaching graffiti removal techniques to cemetery staff may also be necessary if vandalism is an on-going problem. Staff should have access to written procedures



Figure 16. A professional mason works to insert a new piece of stone. Often referred to as a “dutchman”, this repair technique requires replacing the deteriorated stone section with a new finished piece of the same size and material. Photo: Jason Church.

that include lists of appropriate materials and forms for recording the work completed.

Some work is best done by specialists (Fig. 16). For example, unless there is a trained mason on staff, replacing deteriorated or missing mortar will require a skilled masonry contractor. Services of a conservator or trained cemetery specialist should be used for removing severe soiling and staining from grave markers and for carrying out adhesive repair work such as selectively replacing a piece of stone when a marker is damaged by mechanical equipment. Care should be taken to clearly define the scope of work when hiring a contractor. It is useful to reference guidelines and preservation standards, such as those provided by the Secretary of the Interior or the American Institute for Conservation, whenever possible.

Treatments

In historic cemeteries, preservation treatments are used to preserve grave markers and protect them from future deterioration. Tasks such as cleaning, where appropriate, painting, or lime washing may be undertaken both as an initial treatment and on a cyclical basis as part of the maintenance program for the site. Other treatments, including repointing, patching and filling, and resetting, should be undertaken on an as-needed basis.

It is important to note that the Secretary of the Interior’s Standards for Treatment of Historic Properties provide concepts and guidelines for maintaining, repairing, and replacing historic materials. The Standards promote best practices that will help to protect grave markers in historic cemeteries and other irreplaceable cultural resources. If replacement is required, the new material should match the old in composition, design, color, and texture. With chemical and physical treatments, the Standards recommend using the gentlest means possible.

Cleaning

Cleaning is carried out to remove soiling, staining, and contamination from grave markers (Fig. 17). Cleaning improves the visual appearance of the marker and sometimes reveals existing problems such as erosion and cracks. For various protective treatments, cleaning may be a necessary step in surface preparation. Although cleaning often is desirable and beneficial, the use of improper materials and techniques can cause great damage; when cleaning historic grave markers is undertaken, one should keep in mind the principle, “first do no harm.”

To avoid a heavy build-up of soiling that might require aggressive cleaning procedures, regularly scheduled cleaning should be carried out by cemetery staff. The frequency of cleaning depends on a number of factors, including climate, location and vegetation. Before cleaning, an on-site inspection should be conducted to identify monument materials, including those not designated for cleaning since they may inadvertently come in contact with cleaning products and could be harmed. Temporary protective measure may be needed to safeguard nearby grave markers. Identifying the types of soiling present, including pollutants and contaminants, is important in deciding what cleaning procedures to use.

For some monuments, existing conditions may preclude cleaning. Even gentle cleaning may not be recommended for conditions such as severe erosion, advanced deterioration, or fragile areas. Additionally, open joints, unstable repairs, and large cracks may require alternate cleaning procedures.

General maintenance may involve low-pressure water washing. In most cases, surface soiling can be removed with a garden hose using municipal water or domestic

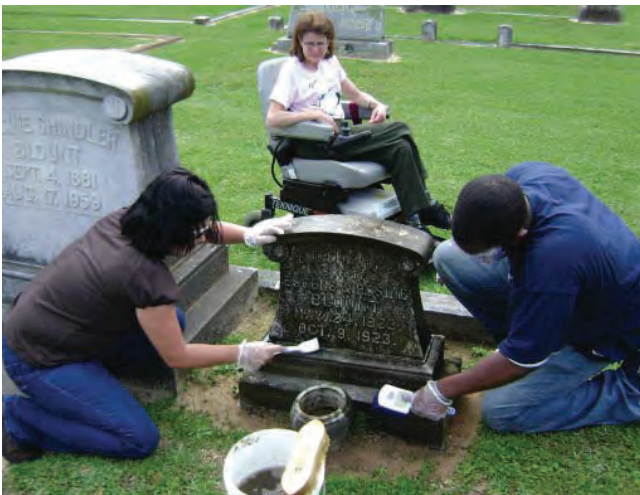

Figure 17. Volunteers can undertake cleaning of grave markers once they have received initial training. Cleaning methods may include wetting the stone, using a mild chemical cleaner, gently agitating the surface with a soft bristle brush, and thoroughly rinsing the marker with clean water. Photo: Jason Church.

Selecting A Conservator or Preservation Professional

A conservator or preservation professional can provide valuable assistance in preserving historic cemeteries by documenting and surveying cemetery conditions, assisting with work plans and prioritizing work, and recommending specific maintenance and repair procedures. More commonly, they recommend more specialized preservation treatments for historic markers and carry out the actual work.

Specialized skills are required for undertaking certain treatments on historic grave markers or where markers are highly significant or are in more advanced states of disrepair. When contracting for grave marker conservation, it is important to interview conservators who have worked in cemeteries. They should be experienced with the historic materials and nature of the conditions where the work is to be undertaken. Prior to selecting a conservator, details about their previous work and training should be obtained and confirmed. Most conservators will provide sample reports and photographs of previous work.

The American Institute for Conservation of Historic and Artistic Works (AIC) offers information about selecting a conservator and what to expect once you have contracted with a conservator. Searching the “Find a Conservator” database provides a list of local and regional AIC members who have attained Professional Associate or Fellow status in the organization. More information can be found on the AIC website at <http://www.conservation-us.org/>

A conservator will inspect grave markers before designing appropriate treatments and submit a written plan for their proposed conservation work that includes materials to be used, a cost estimate, and a schedule for the project. As part of the contract, the conservator should be required to submit a written completion report that clearly describes their treatment of the marker/s and includes maintenance and care recommendations.

water supply from a well. To avoid risks due to freezing, air temperature above 40° F is recommended for the time of treatment and subsequent 24 hours. To help remove stubborn soiling and dirt, soft, natural bristle scrub brushes are best. Avoid metal bristle brushes or firm nylon brushes and wrap metal elements with masking tape to avoid scratching grave markers.

Soaking and/or spraying water in a fine mist are effective methods to remove natural growth. Water also has a “swelling action” for some soiling, making it easier to remove with gentle scrubbing. With cyclic spraying, a fine mist of water is directed at the targeted area for a short time (e.g., 20 minutes or less), followed by a short “off” period. This on/off process is repeated several times. Because high-pressure water can abrade the surface, this treatment is not recommended for masonry monuments.

For stains that are not water soluble or where organic solvents are ineffective, it is sometimes necessary to use chemical cleaning. Chemical cleaners include acids, alkalis, detergents and organic solvents. Each has advantages and disadvantages. Acids dissolve the interface between the stain and substrate while alkalis allow for longer dwell periods but must be neutralized. Some detergents are near-neutral in pH (neither acidic nor alkaline) and easier to rinse.

Before selecting or using a chemical cleaning agent, the manufacturer’s Safety Data Sheet (SDS), available with the product and online, should be reviewed. The SDS provides information about the product’s composition, including identified hazards, proper handling and storage, disposal, and required personal protective equipment. Once a chemical cleaning product has been selected, the manufacturer’s instructions should be followed. Before undertaking large-scale cleaning, it is always advisable to undertake small-scale tests (approximately 6” x 6” areas in discrete locations), and then waiting several days before assessing the results.

Chemical cleaning is used to remove metallic stains and other contaminants such as old coatings and graffiti. For severe staining, poultice cleaning is useful as it extends contact time with the cleaner. A poultice is a mixture of clay or other inert material, such as paper pulp, and a cleaning agent. The mixture is applied to the surface and allowed an extended dwell period. The chemical cleaner dissolves the stain and the clay draws the stain out to the surface. When using a poultice, it should be applied just beyond the stained area and covered with polyethylene. The best practice is to leave the treatment on the surface for 24 hours and then remove the polyethylene cover and allow the poultice to continue drying. Once the poultice is dry, the mixture is then collected and the surface is thoroughly rinsed. For some stubborn stains, the application may need to be repeated.

Chemical cleaning also may be required if biological growth (algae, fungi and lichen) is severe. A study conducted by the National Park Service provides guidelines for cleaning government-issued marble headstones and recommends biocidal cleaners that contain quaternary ammonium compounds. Like all cleaning methods, chemical cleaning can accelerate deterioration. Adverse effects include efflorescence, stains, and etching.

Graffiti Removal

Markers with graffiti tend to be targets for further vandalism (Fig. 18). Timely removal helps deter future vandalism and improves the marker’s appearance.

If the graffiti is water soluble, it can be removed using water and a soft cloth or towel. Rinsing the cloth frequently helps to avoid smearing graffiti on unaffected areas. If the graffiti is not water soluble, organic solvents or commercial graffiti removal products suitable for the grave marker material are recommended. Products should be tested prior to use. General cleaning of the entire marker is a good follow-up for a more even appearance. For deep-seated graffiti, poultice cleaning (previously described) may be required to extract staining materials.



Figure 18. Graffiti is carefully removed using a low-pressure dry-ice misting instrument. Photo: Jason Church.

Repointing

Missing and deteriorated mortar in old cemetery grave markers is a common condition, and the mortar should be replaced to prevent water intrusion and potential damage (Fig. 19). Several questions should be considered when selecting materials for repointing.

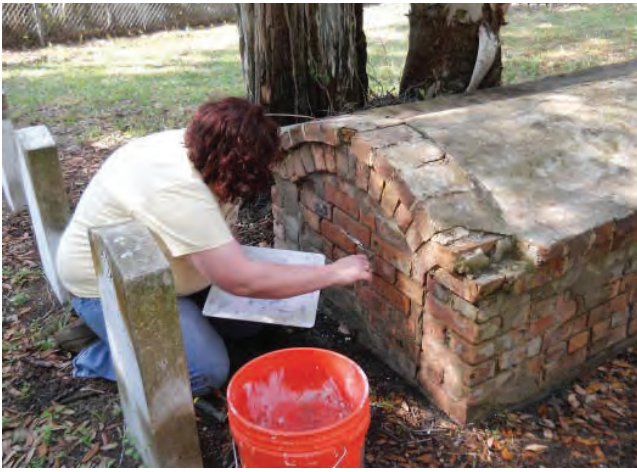

Figure 19. Masonry markers like this box tomb may require the repointing of mortar joints. It is important to use a mortar that is softer than the historic brick. In this case a conservator uses a lime putty-based mortar to repoint. Photo: Jason Church.

Most importantly, what is the masonry substrate that requires repointing? What mortar mix is suitable for the historic masonry? How quickly will mortar need to cure? Soft mortars contain traditional lime putty or modern hydrated lime. Harder mortars contain natural or Portland cement. If necessary, mortars can be tinted with alkali-stable pigments to match historic mortar colors. The selection of the mortar to be used is critically important to the success of the project. An inappropriate mortar can result in unattractive work and accelerate the deterioration of the historic grave marker. Always avoid the use of bathtub caulk and silicone sealants for repointing mortar joints.

Prior to repointing, any loose and deteriorated mortar needs to be removed from the joint, preferably using hand tools. Following joint preparation, the mortar materials (lime, cement, and sand) are mixed, and then water added to form a stiff paste. The repointing mortar is applied using a tuck pointing trowel, typically with a narrow 1/8" - 1/2" flat blade. Mortar is compacted into the joint, and then excess mortar is removed and the original joint profile replicated. Good repointing requires skill. Generally, a mason or person with masonry training should repoint mortar joints.

Resetting

Resetting is recommended for grave markers when their foundations are unstable or out of plumb (Figs. 20a through 20c). This often complex activity involves lifting the grave marker, leveling its foundation, and returning the marker to its original upright position. Workers can be injured and the grave marker damaged if resetting is not carried out properly and safely.

Inexperienced staff or volunteers should not attempt resetting without training from a conservator, engineer, or other preservation professional. When dealing with fragile or significant grave markers, or those with large



Figure 20a. This slate grave marker in the Ancient Burying Ground in Hartford, CT, is a ground-support stone. Resetting requires digging a hole that will hold the base of the stone and then compacting the soil at the bottom of the hole by hand. Photo: Fran Gale.



Figure 20b. To facilitate drainage, crushed stone, gravel, and sharp sand line the hole and are hand-tamped around the stone after placement. Photo: Fran Gale.



Figure 20c. The reset ground-supported grave marker should be level and plumb. Photo: Fran Gale.

Safety

Encouraging the public to visit and explore public burial grounds and cemeteries increases awareness of the value of these sacred sites. If visitation is promoted, owners and property managers must be responsible for ensuring that their sites are safe for staff and visitors. This responsibility includes monitoring the condition of grave markers.

Historic cemeteries can be hazardous workplaces for staff members, consultants, contractors, and volunteers. Awareness of potential hazards in a historic cemetery and careful planning are essential to avoiding injury. Maintain an appropriate first aid kit on site for minor injuries and have an emergency plan in place that includes contact information for medical assistance.

Creating a safe work environment in historic cemeteries requires appropriate planning for each project, starting with personal protective equipment. Suitable clothing and personal protective equipment should be fundamental safety requirements. Supportive shoes such as steel toe work boots or sturdy lace-up shoes help protect ankles and feet from injury, just as good work gloves help protect hands from cuts, scrapes, and splinters. Whether using a chipper, drill and other power tools or equipment, safety glasses or goggles are essential. A back brace often is recommended for heavier lifting tasks. Do not work alone or, if you must, tell someone where you are and when you expect to return.

During hot weather, heat stress is a present risk. Besides knowing the signs of heat stress, preventive measures should be taken by each worker:

- Wear light, loose-fitting, breathable clothing and a broad-brimmed hat.
- Use sunscreen, reapplying as needed.
- Take frequent breaks in the shade.
- Make sure fresh water is available and drink to stay hydrated.
- Eat small meals before and during work.
- Avoid caffeine, alcohol, and large amounts of sugar.

Trip and falling hazards include uneven ground, holes, open graves, toppled grave markers, fallen tree limbs, and other debris (Fig. C). Sitting, climbing, or standing on a grave marker should be avoided since the additional weight may cause



Figure C. Gophers and other burrowing animals produce uneven ground and holes that are trip and falling hazards to visitors and staff of historic cemeteries. Photo: Jason Church.

deteriorated and structurally unstable monuments to break or collapse with serious injury potentially occurring to the worker and damage to the marker. To help prevent injuries that can result from unstable grave markers, it is important to routinely identify and flag severely damaged and unstable grave markers for corrective work and to rope off any marker considered to be in immediate danger of collapse. Prior to beginning work, the immediate area around the job site should be rechecked for safety hazards.

Snakes, wasps, and burrowing animals inhabit historic cemeteries (Fig. D). Snakes sun on warm stones and hide in holes and ledges, so it is important to be able to identify local venomous snakes. An appropriate venomous snake management plan should be in place, and



Figure D. Yellow jackets that are nesting below the projecting molding of this grave marker pose a hazard to visitors and staff because, if disturbed, they will vigorously defend their nest. Yellow jacket, paper wasp and hornet nests should be removed from grave markers by trained staff or specialists. Photo: Jason Church.

all workers should be familiar with it. Workers and volunteers should be instructed as to safety measures to be taken in regards to snakes, including proper clothing where there is an identified risk.

The imported red fire ant is an invasive pest, prevalent in the southern United States. They attack en masse, resulting in painful bites that can be potentially life threatening to people with allergic reactions. It is important to be able to identify the presence of red imported fire ants; be informed as to safety measures to take when working in areas known to be infested with them; and take steps to control them as necessary. A rescue medicine is available for those with serious allergic reactions.

Paper wasps, yellow jackets, and hornets are another concern, building nests around and on ledges and lips of box tombs, mausoleums, and other grave markers. They are very territorial around their nests and will vigorously defend them. There are non-toxic sprays that can be used in and around the work area. Nests should be safely removed.

Burrowing animals like armadillos, groundhogs, gophers, and moles disrupt the ground with their digging and tunnels and can create tripping hazards or undermine grave markers. Prairie dogs have been known to dig up bones and destroy gravesites. Sinkholes created by these animals can also be perfect places for other creatures like snakes to inhabit.

Proper work practices and lifting techniques need to be used whenever lifting or resetting grave markers. Many markers are surprisingly heavy. For example, a common upright marble headstone measuring 42" long, 13" wide, and 4" deep weighs over 200 pounds. Volunteers and workers should work in pairs, be able bodied, and have training in safe



Figure E1. The simple wooden clamp system allows two people to safely lift a marble grave marker. Photo: Sarah Jackson.



Figure E2. The clamp system is constructed from off-the-shelf wooden boards. Photo: Sarah Jackson.

lifting techniques. Lift equipment and ergonomically correct tools should be routinely used to lift heavy markers (for most people this includes markers that weight more than 50 pounds). For smaller grave markers, a simple wooden clamp system can be constructed for a two-person lift (Figs. E1 and E2).

stacked bases, a specialist should be contracted for resetting.

It is important to check state and local regulations to make sure that digging around the grave marker is authorized before starting any resetting effort. Also, grave markers should be documented and cleaned before resetting. It is also a good time to measure and record the overall size of the marker and note any stone carver's marks or inscription of the company that made the marker. The company name is often found on buried portions of the base and revealed during the resetting process.

Typical materials required for resetting include a hoist, shovels, plumb lines, levels, tamping devices, wooden

stakes, and boards. To improve drainage, sand and small gravel or small stones are commonly used when resetting.

Prior to resetting, it is important to establish the type of base. Most grave markers have one of three main base types: (1) ground supported, (2) slotted base, or (3) stacked base. Similar tasks are undertaken for each base type.

Ground-supported stones are a common type of historic grave marker. This type includes the traditional New England slate and brownstone markers and government-issued marble headstones. The primary goal with any ground-supported marker is to have it level and plumb. To reset the marker, a few inches or more of soil is

first removed from around the stone. This is usually sufficient to enable a stone marker to be straightened. The enlarged hole is then filled and compacted around the marker.

If a grave marker has fallen over and has been covered with soil or turf, it must first be inspected for attached concrete or other anchoring system. If this system is still attached, the grave marker may break during lifting. After removing the stone, it can be cleaned and then temporarily set on wood supports.

The hole left from removal of the marker will need to be enlarged to hold the base of the stone. Soil at the bottom of the hole should be compacted by hand, not with a power tamper. In most cemeteries, crushed stone or sharp pea-size gravel mixed with angular sand can be used to line the hole and then hand-tamped around the stone after it is placed in the hole. The gravel helps facilitate drainage and keeps the stone from settling. A bubble level can be used to ensure that the stone is plumb. Markers should not be set in concrete.

The second type of monument base is the slotted base where the upright element is secured to the base using mortise-and-tenon style construction. The upright element in the slotted base may be leaning or loose. In any case, the upright element should be removed from the base, the base leveled, then the element returned to the base. It is important to keep in mind the depth that the base was intended to be set into the ground. This may be indicated by the style of the base or the observed soil-line staining. Many bases were intended to sit flush on grade while some were set a few inches below ground.

Prior to resetting, the upright element should be disengaged from the base and carefully set aside. In most cases, the base will need to be removed to properly prepare the hole before resetting the grave marker. After doing so, four to six inches of soil should be removed from the hole and the soil then tamped by hand to make a proper bed or foundation. The foundation area can be filled with crushed stone or sharp pea-sized gravel and sand, checking to make sure that the base is plumb and level as resetting proceeds. Clean the headstone prior to resetting. Old mortar, concrete or epoxy should be removed from the slot and the bottom of the upright element using a hammer and small chisel. Once the stone elements are cleaned and the base is level and plumb, the next step is placing the upright element into the slot. A lime mortar can be used to fill any gaps in the slot. This prevents water intrusion that may cause marker movement related to freeze-thaw cycles.

A third common base type is the stacked base. This style includes at least one element placed on a base or a series of bases of varying sizes. Resetting a stacked-base grave marker usually requires special skills and lifting equipment. Depending upon the complexity of the marker, a conservator, experienced masonry contractor,

or preservation professional with engineering skills is usually needed.

The sections of a stacked-base grave marker often are pinned together for support. If deteriorated, the pins should be replaced. Using a hammer and chisel, a conservator or person experienced in working with historic grave markers should remove any corroded iron, copper, or bronze pins, as well as the old mortar or adhesive adhered to each section. Replacement pins should be stainless steel all-thread, and sized slightly shorter and smaller than the existing hole. The replacement pins then can be set with epoxy, lime mortar, or packed in lead. Once the pins are in place, the sections of the stacked base can be individually reset using traditional or contemporary materials. These include lead, shims, mortars, and setting compounds. Finally, each gap or seam between sections should be pointed with a setting compound or appropriate mortar to prevent water intrusion.

Filling and Patching

Hairline masonry cracks may be the result of natural weathering and require no immediate treatment except to be photographed and recorded. However, larger cracks often merit further attention. Repairing masonry cracks involves several steps and typically a skilled hand (Fig. 21). The repair begins with the removal of loose material and cleaning. Materials that are used for crack repair include grouts for small cracks and epoxy for large cracks affecting the structural integrity of the monument. Gravity or pressure injection is used to apply grout or epoxy. Crack repair can be messy, so careful planning and experience are helpful. If the crack is active, a change in size of the crack will be noted over time. Active cracks require further investigation to ascertain the cause of the changes, such as differential settlement, and to correct, if possible, the cause prior to repairing the crack.



Figure 21. Cracks in a stone marker should be filled to keep water and debris out and prevent the crack from becoming larger. A patching mortar is designed to be used, in this case, with historic marble. Photo: Mary Striegel.

Repairing masonry markers with severely damaged or missing pieces requires a skilled mason or conservator. The materials used for patching are similar to those used for repointing mortar joints. With patching, it is critical that the physical and mechanical properties of the patching material be appropriate for the masonry material. Work includes designing a durable patch compatible with the substrate. Proper curing is especially critical for large patches and often involves procedures to protect the patch from premature drying. Repairs to stucco-covered surface should be carried out by a skilled plasterer using a stucco mix that is compatible with the original material.

Repairing delaminated slate and brownstone grave markers also requires a skilled mason or conservator. With this condition, there are openings along bedding planes which expose the stone grave marker to moisture intrusion. Treatments are design to eliminate or reduce moisture intrusion that would accelerate deterioration. The selection of appropriate repair materials and procedures depends on the severity of the condition. Traditionally, delaminated slate or brownstone grave markers were "capped" with a strip of lead or other metal. Today, this repair technique is seldom used, in part because the drilling procedure used to attach the cap can be damaging, if the stone is brittle. Also, there are toxicity issues associated with the use of lead. An alternative approach is to fill the openings exposed by delamination with grout or patching material that is compatible with the stone. Adhesion of the repair material to the delaminated surfaces is particularly important.

The decision whether to use patching material or undertake a dutchman repair with matching material depends on the grave marker material, location of the damaged area, size, and other factors. A successfully executed dutchman usually results in a repair that has long durability and maintains a similar weathering pattern to the adjacent historic material. When working with stone grave markers, repairs using dutchman techniques are best done by a skilled stone craftsman.

Detached fragments should be collected, documented and stored in a suitable facility. Reattachment of these fragments should be undertaken by a conservator or mason. This work often requires pins to reinforce the joints and patching to compensate for losses.

Protective treatments

Protective treatments for metal, stone, and wood grave markers stabilize corrosion and protect the monument from rainwater, pollutants, and other contaminants. Treatments may vary not only due to material differences, but also to specific site conditions.

Wax coatings are often used for bronze markers (Fig. 22). Wax provides a protective barrier against moisture, soiling, and graffiti. There are several steps in the wax application process. Where there is little corrosion, gentle cleaning of the marker is undertaken prior to applying the wax coating. Apply a thin layer of wax to the marker using a stencil brush or chip brush. Mineral spirits can be added to the wax to facilitate



Figure 22. A protective coating must be maintained on metal elements. Wax or lacquer coatings help preserve the bronze patina and slow corrosion. Conservators apply a microcrystalline wax to this bust at St. Mark's Church in-the-Bowery, New York, NY. Photo: John Scott.

brush application. A soft, clean cloth is used to remove excess wax and buff the surface. A second coat of wax is sometimes needed.

In most climates, iron objects require coatings to protect them from corrosion. Clear coatings are sometimes used to protect wrought iron objects. A corrosion inhibitive primer and topcoat are used for cast iron and steel objects. Direct-to-Metal (DTM) coatings combine the two. Because of their durability, acrylic enamels, urethane, and fluoropolymer coatings are preferred. Proper surface preparation is important, including the removal of surface soiling, flaking paint, and loose rust. This can be accomplished with compressed air, wire brushing, solvent rinsing, or other cleaning method. Next the surface is cleaned with a damp cloth, repeatedly rinsing the cloth as needed. While the surface needs to be thoroughly dried before painting, it is important to repaint as soon as possible since even overnight condensation deposits are not desirable.

Another approach for iron objects is using a rust converter to stabilize corrosion that involves less surface preparation. Commercially available rust converters contain tannin or phosphoric acid and react with rust to form more stable iron compounds. The surface must be painted following surface preparation with the rust converter.

Limewash is a traditional coating that brightens stucco-covered grave markers (Fig. 23). Like paint coatings, it needs to be periodically applied. Limewash is prepared with lime putty or hydrated lime and water. Curing begins following application. The lime putty or hydrated lime reacts with carbon dioxide in the air in a process called carbonation. This reaction eventually forms calcium carbonate, a stable hard coating. Limewash is a “green” coating with no volatile organic compound content and is “breathable,” i.e., it allows for water vapor transmission. Although commonly white, limewash can be colored or tinted with alkali-stable pigments such as iron oxide.



Figure 23. Limewash is a breathable coating sometimes used to protect the surface of the grave marker and provide a decorative finish. Limewash is applied by brush in five to eight thin coats (with each coat about the consistency of skim milk). The surface is allowed to slowly dry between coats. Sometimes the surface is covered by damp burlap to slow the drying process. Photo: Sarah Jackson.

Before applying the limewash, the masonry surfaces should be inspected for coating residues that need to be removed and any required repair work undertaken. Stucco-covered surfaces should be repaired and allowed to fully cure before applying limewash. If the original color has been determined, the renewal coating can be formulated to match. In preparing the wash, enough water is added to lime putty or hydrated lime to produce slurry with the consistency of skim milk. A mixture of four parts water and one part lime usually works well. A Zahn or Ford cup can be found at a hardware store and used to measure the thickness of the limewash and ensure consistency with each batch. Although many traditional recipes include additives, a simple mixture of lime and water performs best. Using a power drill with a paddle attachment to stir the limewash will help ensure that the lime particles are fully suspended in the

mixture. Any pigment for coloration is added during the final mixing.

The surface must be cleaned of old coating residues, soiling, and other contaminants. After dampening the surface, the limewash is applied in 5-8 thin coats, allowing each coat to dry between applications. Limewash is translucent immediately after application and then becomes opaque when dry.

Proper curing of limewash is critical to its durability. To prevent premature drying, the treated surface may need to be covered with damp burlap. Limewash must not be applied when frost or freeze conditions are predicted or in temperatures above 90° F. Ideally, limewash should be applied during spring or fall when temperatures are around 70° F, avoiding direct sunlight where possible.

Clear water repellents and consolidation treatments are sometimes considered for severely deteriorated grave markers, including unpainted wood markers and masonry. For wood markers, epoxy consolidants are used to patch and repair. For masonry materials, it is important to remember that they are porous, and water vapor and liquid water can travel through their internal network. Protective treatments must allow for water vapor transmission to prevent trapping moisture inside the marker. Although a wide variety of water repellents have been employed on masonry (wax, acrylic, epoxy resins, etc.), silane and siloxane treatments have been the most successful. These organosilicon compounds are “breathable,” penetrate below the surface, and form chemical bonds with silicate minerals.

When erosion is severe, consolidation treatments (e.g., ethyl silicate) have been used to replace mineral binders lost to weathering (Fig. 24). Because these treatments are not reversible, laboratory and on-site testing are essential. Application by a conservator or other experienced preservation professional is advised.

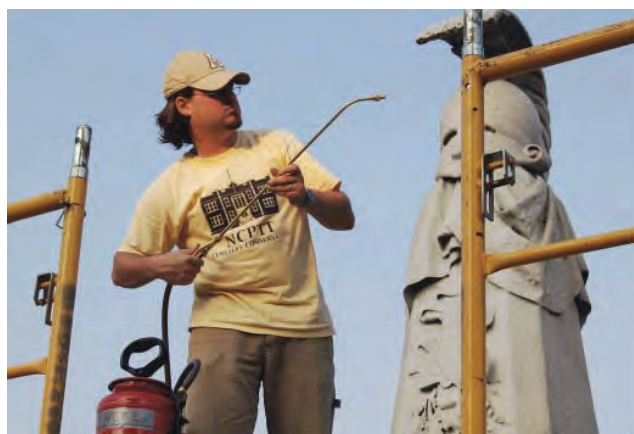

Figure 24. A severely deteriorating monument or grave marker can be treated with a stone consolidant. The treatment is usually applied using a spray system. The consolidant soaks into the stone and replaces mineral binders that hold the stone together. On-site and laboratory testing and evaluation are performed prior to using this non-reversible type of treatment. Photo: Lucas Flickinger.

Conclusion

Maintenance is the key to extending the life of historic cemetery grave markers. From ensuring that markers are not damaged by mowing equipment and excessive lawn watering, to proper cleaning and resetting, good cemetery maintenance is the key to extending the life of grave markers. Whether rescuing a long-neglected small cemetery using volunteers or operating a large active cemetery with paid staff, the cemetery's documentation, maintenance and treatment plans should include periodic inspections. Only appropriate repair materials and techniques that do not damage historic markers should be used and records should be kept on specific repair materials used on individual grave markers. A well-maintained cemetery provides an attractive setting that can be appreciated by visitors, serves as a deterrent to vandalism, and provides a respectful place for the dead. A community history recorded in stone, wood and metal markers, cemeteries are an important part of our heritage, and are deserving of preservation efforts (Fig. 25).



Figure 25. Involving the community in activities helps to develop an appreciation for the cemetery and serves to deter vandalism. Events may include children through school or scouting organizations and can help teach across the curriculum. Photo: Debbie Dietrich Smith.

Additional Reading

Stragstad, Lynette. *A Graveyard Preservation Primer*. Altamira Press; Second Edition (August 28, 2013)

Jackson, Sarah Marie, Tye Botting and Mary Striegel, "Durability of Traditional and Modified Limewashes," *APT Bulletin*, Vol. 38, No. 2/3, 2007.

Matero, Frank G. and Judy Peters. "Survey Methodology for the Preservation of Historic Burial Grounds and Cemeteries." In *APT Bulletin*, Vol. 34, No. 2/3 (2003), pp. 37-45.

Grissom, Carol A. and Ronald S. Harvey. "The Conservation of American War Memorials Made of Zinc." In *Journal of the American Institute for Conservation*. Vol. 42, No. 1, Architecture Issue (Spring, 2003), pp. 21-38

National Park Service publications, NCPTT:

Best Practice Recommendations for Cleaning Government-Issued Headstones. Mary F. Striegel, 2011.

Wooden Artifacts in Cemeteries: A Reference Manual. Ronald W. Anthony and Kimberly Dugan. 2007

Identification of Unmarked Graves. Rinita A. Dalan, Steven L. DeVore and Earl Clay. 2008

National Park Service publications, Technical Preservation Services:

A Glossary of Historic Masonry Deterioration Problems and Preservation Treatments. Anne E. Grimmer. 1984, reprinted.

Keeping It Clean. Anne E. Grimmer. 1988.

Preservation Brief 1: Cleaning and Water-Repellent Treatments for Historic Masonry Buildings. Robert C. Mack, FAIA, and Anne E. Grimmer. 2000.

Preservation Brief 2: Repointing Mortar Joints in Historic Masonry Buildings. Robert C. Mack, FAIA, and John P. Speweik. 1998.

Preservation Brief 15: Preservation of Historic Concrete. Paul Gaudette and Deborah Slaton. 2007.

Preservation Brief 22: The Preservation and Repair of Historic Stucco. Anne Grimmer. 1990.

Preservation Brief 38: Removing Graffiti from Historic Masonry. Martin E. Weaver. 1995.

Preservation Brief 42: The Maintenance, Repair and Replacement of Historic Cast Stone. Richard Pieper. 2001.

Preservation Tech Note 1: Conserving Outdoor Bronze Sculpture. Dennis Montagna. 1989.

National Park Service, National Register Bulletins:

Guidelines for Evaluating and Registering Cemeteries and Burial Places. Elisabeth Walton Potter and Beth M. Boland. 1992.

National Park Service publications, Museum Management Program:

Conserve O Gram, 10/4 Caring for Outdoor Bronze Plaques, Part I: Documentation and Inspection. 2005

Conserve O Gram, 10/5 Caring for Outdoor Bronze Plaques, Part II: Cleaning and Waxing. 2005.

About the Authors

Dr. Mary Striegel directs the Material Conservation Program at the National Park Service's National Center for Technology and Training (NCPTT) in Natchitoches, Louisiana. Frances Gale is the former Training Chief (NCPTT) and currently is a Senior Lecturer and Director of the Architectural Conservation Laboratory, University of Texas at Austin. Jason Church is a Materials Conservator with NCPTT. Debbie Dietrich-Smith is the Chief, Historic Landscape Program, NCPTT.

Acknowledgements

The authors wish to thank Francis Miller, Conservator, ConserArt LLC; Mark Wolfe, Executive Director and Jennifer McWilliams, Cemetery Preservation Program Coordinator, Texas Historical Commission; Gus Fraser, Vice President of Preservation and Facilities, Mount Auburn Cemetery; Sara Amy Leach, Senior Historian and Jennifer Perunko, Historian, National Cemetery Administration, Department of Veterans Affairs; and Jenny Parker Technical Preservation Services, National Park Service for their insightful comments in reviewing the brief. Thanks also go to Kirk Cordell, Executive Director, NCPTT, and Brian Goeken, Chief, Technical Preservation Services. Charles Fisher, Technical Preservation Services provided invaluable assistance in the editing and preparation of this brief.

This publication has been prepared pursuant to the National Historic Preservation Act, as amended, which directs the Secretary of the Interior to develop and make available information concerning historic



Whether large or small, well maintained or neglected, historic cemeteries are an important part of our cultural landscape. This historic cemetery at Cape Lookout National Seashore, NC, provides a record of the families who lived in Portsmouth Village during the 19th and early 20th centuries. Photo: Fran Gale.

properties. Additional information offered by Technical Preservation Services is available on our website at www.nps.gov/tps. Further information on the programs and resources of the National Center for Preservation Technology and Training can be found at www.ncptt.nps.gov. Comments about this publication should be made to: Technical Preservation Services, National Park Service, 1849 C Street NW, Washington, DC 20240.

This publication is not copyrighted and can be reproduced without penalty. Normal procedures for credit to the authors and the National Park Service are appreciated. Excepting for the photographs by the authors, the photographs used in this publication may not be used to illustrate other print or electronic media without permission of the owners. Photographs by the authors should be credited with author's name, NCPTT.

A
Glossary of
Historic
Masonry
Deterioration
Problems
and
Preservation
Treatments



A Glossary of Historic Masonry Deterioration Problems and Preservation Treatments

Compiled by Anne E. Grimmer

Department of the Interior
National Park Service
Preservation Assistance Division

1984

For sale by the Superintendent of Documents, U.S. Government Printing Office
Washington, D.C. 20402

**Library of Congress Cataloging in
Publication Data**

Main entry under title:

A Glossary of historic masonry deterioration
problems and preservation treatments.

Bibliography: p.

Supt. of Docs.: I 29.2:H62/19

1. Masonry—Dictionaries. 2. Historic
buildings— Conservation and restoration—
Dictionaries.

I. Grimmer, Anne E. II. United States.

National Park Service. Preservation Assistance
Division.

TH5321.G56 1984

693'.1

84-60027

Contents

Part 1: Deterioration Problems	1
Blistering	3
Chipping	4
Coving	5
Cracking	6
Crazing	7
Crumbling	8
Delamination	9
Detachment	10
Efflorescence	11
Erosion	12
Exfoliation	13
Flaking	14
Friability	15
Peeling	16
Pitting	17
Rising Damp	18
Salt Fretting	19
Spalling	20
Subflorescence	22
Sugaring	23
Surface Crust/Surface Induration	24
Weathering	25
Part 2: Preservation Treatments	27
Maintenance	
Application of Surface Coatings	
Paint	31
Parging/Pargeting	32
Stucco	33
Waterproof Coating	35
Water-repellent Coating	36
Caulking	38
Cleaning Methods	
Abrasive Cleaning	39
Chemical Cleaning	41
Paint Removal	42
Poulticing	44
Water Washing	46
Repair	
Composite Patching/Plastic Repair	50
Consolidation	52
Dampproof Course	54
Dutchman Repair	56
Epoxy Repair	57
Mechanical Repair	58
Replacement/Patching with Like or Compatible Substitute Materials	59
Repointing/Tuckpointing	61
Selected Reading List	63

Preface

In 1981, the Preservation Assistance Division of the National Park Service initiated the Census of Treated Historic Masonry Buildings in order to fulfill its responsibility to provide sound technical advice to Federal, State, and local officials concerning the preservation of historic structures. The purpose of the Census is to establish a system for documenting all types of treatments carried out on historic masonry and for keeping a record of environmental and treatment effects on the long-term preservation of the masonry. How to identify the many kinds of deterioration to which historic masonry is susceptible, and how to determine what, if any, treatment is best, or what degree of intervention might be necessary for its preservation, are not easy questions to answer. The continuing influx of new "miracle" products on the market makes these questions even more problematic. Although most of these products were originally developed for application in new construction, many are now being promoted by the manufacturer, or by architects and building contractors, as equally suitable for older and historic masonry materials. Too often, an incorrect and uninformed diagnosis of masonry deterioration results in the application of many such products—in particular water-repellent coatings and consolidants—to historic buildings without adequate, or in most cases without *any*, testing. Unfortunately, this haphazard use of inappropriate or incompatible materials often results in extensive and irreversible damage to the historic masonry.

To date, twenty historic masonry buildings have been recorded on the Census, reflecting a variety of treatments, masonry types, geographical locations, and it is estimated that the project will ultimately include one hundred structures. As the Census project has evolved, we have realized the need for a standard set of definitions for masonry deterioration as well as the preservation treatments prescribed. There is a plethora of terms used to describe problems of historic masonry deterioration and preservation treatments. Because so many of these terms originate from different sources—the architectural profession, the building trades and industry, and scientific fields such

as geology and chemistry—many of them are used interchangeably, often indiscriminately and incorrectly. As a result, the preservation architect or building conservator is left in confusion, uncertain not only how to diagnose a problem, but what to call it, and whether to recommend a treatment.

To help clarify these different, but sometimes nearly synonymous terms, we have developed this illustrated glossary. The glossary is *not* a "how to" manual; it will not supply the technical information, such as specifications, necessary to carry out a cleaning or repair project. Instead it is intended as a general reference and interpretive tool to provide an explanation of all terms likely to be used in the Census to describe conditions of masonry deterioration and repair techniques and treatments to preserve historic masonry.

For purposes of the Census and the glossary, the term "masonry" includes all types of natural stone, brick, terra cotta and adobe, as well as concrete and other cementitious materials. Preservation treatments are broadly defined to include almost everything done to or applied to historic masonry in an effort to prolong its life. The glossary is illustrated and consists of two sections: Part 1 lists and defines problems of masonry deterioration in alphabetical order. Part 2 describes preservation treatments, grouped according to maintenance or repair techniques. It is hoped that the glossary will be useful to all those who are faced with the myriad problems of evaluating, preserving, restoring and rehabilitating historic masonry buildings. This includes historic preservation specialists and architects, architectural and museum conservators, and conservation scientists, as well as representatives of the building industry—such as contractors and masons, and building product representatives.

Although gathered from a wide variety of sources, we realize this glossary is by no means conclusive. It is presented as an initial effort and is intended as the first of many expanded editions to be improved through use and application in the field. We solicit your comments and suggestions for additional terms explaining historic masonry deterioration, and, as the science of masonry conservation continues to evolve, descriptions of new, more suc-

cessful and long-lasting preservation treatments for historic masonry.

The Preservation Assistance Division would like to express its appreciation to all those who have conveyed their experience with historic masonry through the publications which were consulted in the preparation of this glossary, and which are included in the selected reading list. In addition, I would like to personally acknowledge the contribution of the following individuals who provided technical comments on the manuscript: Michael F. Lynch; Erhard M. Winkler; the AIA Committee on Historic Resources; the National Park Service Regions; and the staff of the Preservation Assistance Division, including Michael J. Auer, Bruce Doe, Susan Dynes, Charles E. Fisher, Martha A. Gutrick, Alicia Hardison, H. Ward Jandl, Sharon C. Park, Susan I. Sherwood, Mae Simon, Christopher A. Sowick, and Kay D. Weeks.

This publication has been prepared pursuant to The National Historic Preservation Act Amendments of 1980, which direct the Secretary of the Interior to make available to Federal agencies, State and local governments, private organizations, and individuals information concerning professional methods and techniques for the preservation of historic properties and for the administration of the historic preservation programs at the Federal, State, and local levels. The publication is further evidence of the National Park Service commitment to identify and assess damage to materials and cultural resources as part of its participation in Taskgroup G of the National Acid Precipitation Assessment Program. *A Glossary of Historic Masonry Deterioration Problems and Preservation Treatments* has been developed under the technical editorship of Lee H. Nelson, AIA, Chief, Preservation Assistance Division, National Park Service, U.S. Department of the Interior, Washington, D.C. 20240. Comments on the usefulness of this information are welcomed and can be sent to Mr. Nelson at the above address.

The publication is not copyrighted and can be reproduced without penalty. Normal procedures for credit to the author and the National Park Service are appreciated.

September, 1984

Part 1 Deterioration Problems

Part 1 provides definitions of the most common deterioration problems affecting historic masonry buildings. While there is an obvious similarity of meaning in a number of the terms—the terms blistering, delamination, exfoliation, flaking, peeling and salt fretting are notable examples—all possible definitions have been included in order to be comprehensive. The 22 terms include all levels of deterioration. For example, they run the gamut from lesser problems which appear to be fairly insignificant, such as blistering, to the more serious conditions of delamination or exfoliation. While it would be ideal to reference a treatment for every deterioration problem in the glossary, the very nature of masonry—the fact that stone is not a homogeneous substance, and manufactured masonry materials are not much more consistent—means that any treatment must be carried out only after testing and on a case-by-case basis. Some traditional preservation treatments have been tried and used successfully for a long time, as have some “modern scientific” treatments. But many others have not, and their application has resulted in greater damage to the masonry. Thus, it is clear that technology has not advanced to the point where there is a treatment for every problem. Where a preservation treatment or approach *can* be suggested, however, it is referenced after the description of the problem.

Finally, the reader should understand that if the degree of deterioration is minimal, it is preferable to leave the masonry alone, as long as the problem does not threaten the structural integrity of the building or detract too much from the architectural character. Historic buildings are old and they should not be expected to look perfect.

Blistering

Swelling accompanied by rupturing of a thin uniform skin both across and parallel to the bedding plane, usually a condition found on sandstone, but also on granite. Because blistering can be caused by de-icing salts and ground moisture, it is generally found on a surface close to the ground. Blistering may remain a relatively constant condition scattered over the masonry surface but, more often, it eventually results in greater surface peeling (exfoliation, delamination or spalling).

Preservation Treatment: To date, no completely effective treatment has been developed for this condition.

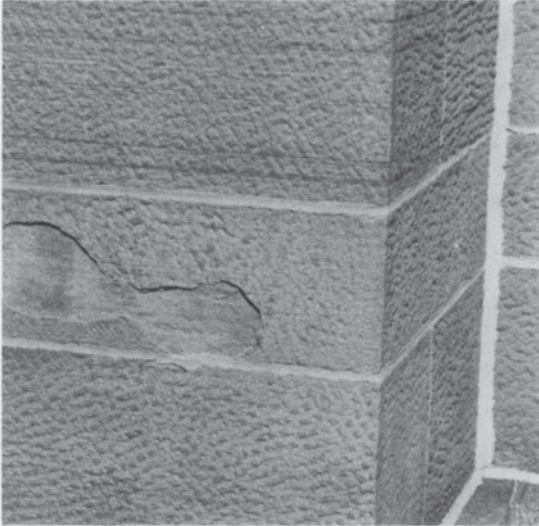

Blistering of sandstone. Photograph: Anne E. Grimmer.

Chipping

Small pieces or larger fragments of masonry separating from the masonry unit, often at corners or mortar joints. This may be the result of damage caused by later alterations or repairs, such as use of too hard a mortar, or by accident or through vandalism.

Preservation Treatment: See Dutchman Repair, p.56; Replacement/Patching with Like or Compatible Substitute Materials, p.59.



Chipping of granite sill. Photograph: Anne E. Grimmer.

Coving

The hollowing out of an adobe wall just above grade level. Coving may be caused by standing rainwater or rainwater splash off the ground. It can also be caused by salts deposited in the adobe by the evaporation of water.

Preservation Treatment: See Replacement/Patching with Like or Compatible Substitute Materials, p.59.



Coving of adobe wall. Photograph: National Park Service.

Cracking

A term describing narrow fissures from 1/16 to 1/2 inch wide in a block of masonry. Cracking may result from a variety of conditions, such as structural settlement of a building, too hard a repointing mortar, or it may be an inherent characteristic of the masonry itself, such as unfired brick or adobe. Small cracks within a single block of masonry may not be serious, but longer and wider cracks extending over a larger area may be indicative of structural problems, and should be monitored.

Preservation Treatment: See Mechanical Repair, p.58; Replacement/Patching with Like or Compatible Substitute Materials, p.59.



Cracking of limestone. Photograph: John H. Myers.

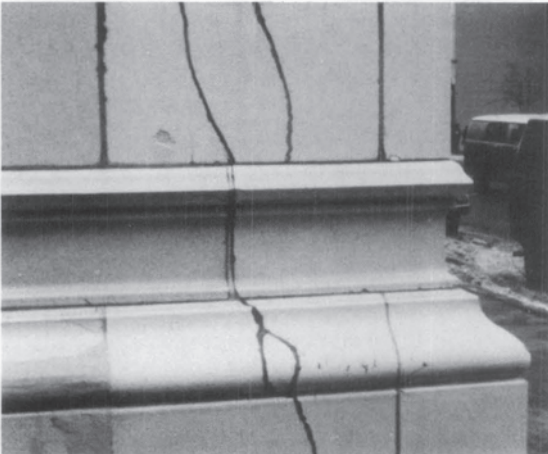

Cracking of glazed terra cotta. Photograph: National Park Service.

Crazing

The formation of a pattern of tiny cracks or crackles in the glaze of glazed terra cotta. Crazing (dunting as it is called when it occurs immediately after the firing process and is caused by too rapid cooling) may develop over time as the terra cotta is exposed to the weather. When a terra cotta unit first comes from the kiln after firing, it has dried to its smallest possible size. With the passage of time it expands as it absorbs moisture from the air. The glaze then goes into tension because it has a lesser capacity for expansion than the porous tile body; it no longer "fits" the expanding unit onto which it was originally fired. If the strength of the glaze is exceeded by this expansion, the glaze will crack or craze (sometimes called moisture crazing). Unless the cracks visibly extend into the porous tile body beneath the glaze, crazing should not be regarded as highly serious material failure. It does, however, tend to increase the water absorption capability of the glazed terra cotta unit.

Crazing can also occur on the surface of concrete, generally due to its expansion and contraction, or by excessive water or improper trowelling of a too-rich mix.

Preservation Treatment: To date, no completely effective treatment has been developed for this condition.



Crazing of glazed terra cotta. Photograph: National Park Service.

Crumbling

This condition is indicative of a certain brittleness or tendency of the masonry to break up or dissolve. It may be caused by an inherent weakness of the masonry and gradual dissolution of the binder, or it may be the result of external factors affecting the strength or durability of the masonry, such as salts or moisture entering the masonry.

Preservation Treatment: See Consolidation, p.52.



Crumbling limestone resulting primarily from excess moisture penetration. Photograph: National Park Service.

Delamination

A condition of stone in which the outer surface of the stone splits apart into laminae or thin layers and peels off the face of the stone.

Because of their layered composition, this may be a natural condition of sedimentary stones such as sandstone or limestone; and the presence of clay-rich layers can accelerate the process. Delamination differs from spalling in that it is a condition confined to natural, primarily sedimentary, stone and is not a condition that occurs in manufactured products, such as brick.

When sedimentary stones are used in building, this tendency to peel off in layers can be exacerbated by improperly laid stones. Delamination takes place along the natural bedding planes of the stones when they are laid vertically, instead of horizontally—the correct way—and, as a result, are exposed to weathering.

Preservation Treatment: See Stucco, p. 33; Composite Patching/Plastic Repair, p.50; Mechanical Repair, p.58; Replacement/Patching with Like or Compatible Substitute Materials, p.59.

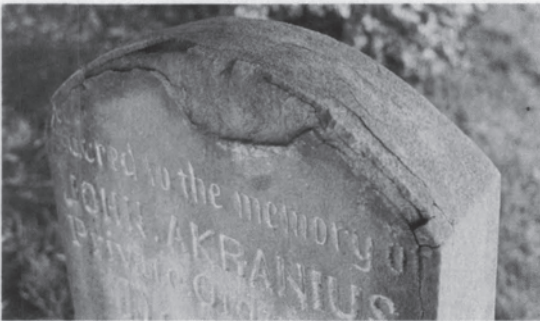

*Delamination of sandstone along the bedding planes.
Photograph: U.S. Corps of Engineers.*

Detachment

The result of a complete break (or failure of an original construction joint) in which the detached portion of masonry survives intact.

Preservation Treatment: See Mechanical Repair, p.58.

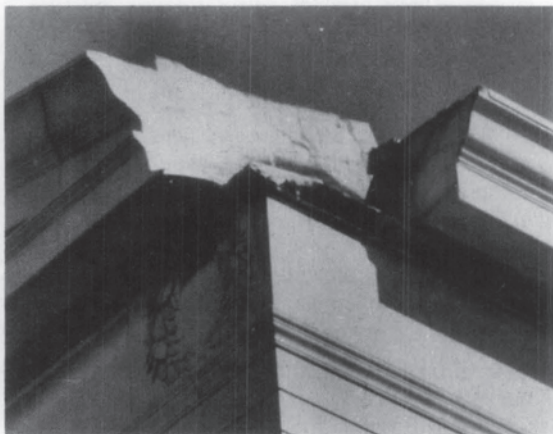

Detachment of section of marble pediment. Photograph: Walter Smalling.



Section of marble lying on the ground at base of building after it had separated from pediment above. Photograph: Walter Smalling.

Efflorescence

A whitish haze of soluble salts on masonry generally caused by excessive "pulling" of soluble salts into the masonry and out through the surface. Capillary action may pull soluble salts which result in efflorescence from the ground into the masonry, such as chlorides from salting of streets and sidewalks in winter and nitrates from fertilizers. In addition, carbonates from lime mortar and air-borne or water-deposited pollutants in the atmosphere may cause sulfates to be deposited on the surface of the masonry. Sulfates resulting from the curing and firing process are a common source of efflorescence in brick. Finally, efflorescence may be a combined salt residue left on the masonry surface by chemical cleaning, too strong a chemical solution, or improper rinsing.

Efflorescence itself may be more unsightly than harmful, but its presence on an older or historic masonry building often serves as a warning, indicating that water has found a point of entry into the structure. Once this has occurred, more serious damage can usually be predicted. Efflorescence may also indicate salt accumulations under the surface of the masonry (subflorescence) which are potentially damaging to the masonry, and are most definitely a matter of concern.

Preservation Treatment: See Poulticing, p.44; Water Washing, p.46.



Efflorescence and spalling on brick wall. Photograph: Anne E. Grimmer.

Erosion

Wearing away of the surface, edges, corners or carved details of masonry slowly and usually by the natural action of wind or windblown particles and water. Erosion is one of the most serious kinds of adobe deterioration.

Preservation Treatment: See Replacement/Patching with Like or Compatible Substitute Materials, p.59.



Differential erosion of sandstone steps follows bedding planes of greater and lesser resistance. Photograph: Anne E. Grimmer.

Exfoliation

Exfoliation, like delamination, is a term primarily used to describe natural stone deterioration. Peeling, scaling or flaking off of the surface of stone in thin layers is caused by the expansion and contraction of trapped moisture, by chemical action such as rusting of metal, or by weathering. Exfoliation most often occurs along natural bedding planes, resulting in an unevenly layered surface. Incorrectly laid stones with their bedding plane laid up parallel or perpendicular to the surface of the building thus have a natural tendency to exfoliate faster, following the lines of the bedding planes.

Preservation Treatment: See Stucco, p.33; Composite Patching/Plastic Repair, p.50; Mechanical Repair, p.58; Replacement/Patching with Like or Compatible Substitute Materials, p.59.



Exfoliation of sandstone. Photograph: Anne E. Grimmer.

Flaking

Flaking is an early stage of peeling, exfoliation, delamination or spalling, and is best explained as the detachment of small, flat, thin pieces of the outer layers of stone from a larger piece of building stone. Flaking is usually caused by capillary moisture or freeze-thaw cycles that occur within the masonry. The application of a water-repellent coating may result in flaking of the masonry when trapped moisture is forced to the surface.

Flaking also commonly occurs in masonry coatings, such as paint, or stucco, and results from a loss of adhesion between the coating and the masonry substrate.

Preservation Treatment: To date, no completely effective treatment has been developed for this condition.



Flaking of granite. Photograph: Baird M. Smith, AIA.

Friability

An inherent characteristic of some types of stone, particularly sandstone or limestone, which have a tendency to break up, crumble or powder easily.

Preservation Treatment: See Consolidation, p.52.

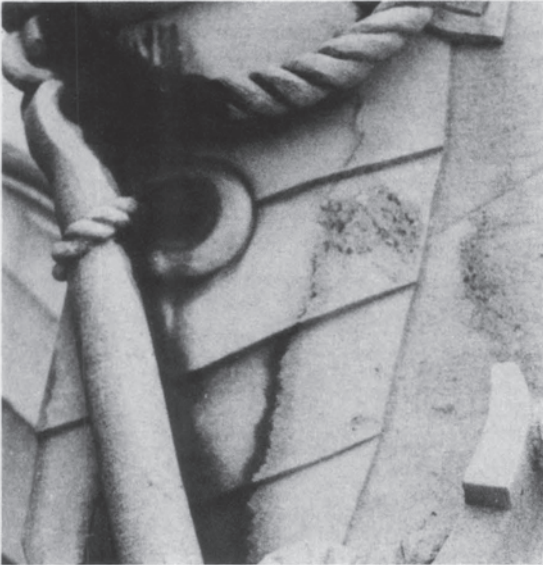

Friability in limestone. Photograph: Anne E. Grimmer.

Peeling

Peeling of stone may be caused by an inherent defect in the surface of the masonry or the result of weathering. Improper application of a masonry coating may result in a lack of adhesion to the substrate, and cause the surface of the masonry or coating to flake or peel away from the substrate in strips or layers.

Peeling may also describe a condition of terra cotta in which the glaze or slip has separated from the body of the terra cotta unit. It may be caused when slip is applied to a terra cotta unit that is too dry or a glaze is applied too thickly or to a dusty surface.

Preservation Treatment: To date, no completely effective treatment has been developed for this condition.



Peeling of granite. Photograph: Baird M. Smith, AIA.

Pitting

The development or existence of small cavities in a masonry surface which may be caused by the differential removal of individual components of the masonry and may be the result of natural weathering or erosion of an inherently porous type of masonry. Pitting may also result from a harsh or abrasive cleaning method. Pitting of concrete can be caused by improper mixing, and usually occurs during the curing period.

Preservation Treatment: To date, no completely effective treatment has been developed for this condition.

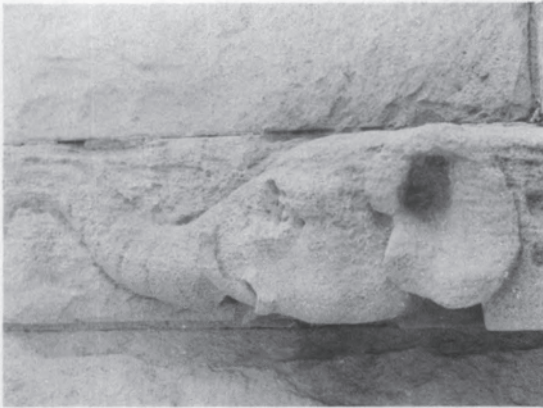

Pitting of limestone. Photograph: John H. Myers.

Rising Damp

The suction of groundwater into the base of masonry walls through capillary action is called rising damp. Moisture is drawn up into the building walls and released at the interior and exterior surfaces where a horizontal wet stain or tidemark is left. The moisture often carries with it salts in solution, which can result in efflorescence and lead to deterioration of masonry, plaster, wood and paint. Rising damp, often the result of improper drainage, is a problem common to many older masonry structures, and one that is difficult to solve completely.

Preservation Treatment: See Dampproof Course, p.54.



*Rising damp evidenced on parged foundation.
Photograph: John Stubbs.*

Salt Fretting

Sometimes called salt erosion, this condition results in an obvious pattern of erosion or etching of the stones caused by salt, usually from the salting of icy sidewalks. Unless the use of de-icing salts is discontinued, this condition can eventually result in spalling and exfoliation of the stone surface.

Preservation Treatment: To date, no completely effective treatment has been developed for this condition.

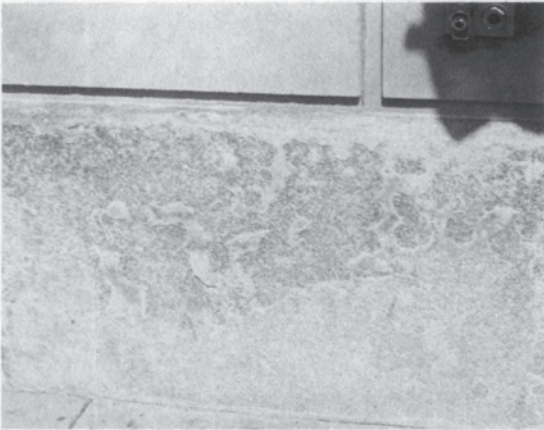

Salt fretting on granite base probably resulting from use of de-icing salts on sidewalk. Photograph: Anne E. Grimmer.

Spalling

A condition of masonry in which the outer layer or layers begin to break off (unevenly), or peel away in parallel layers from the larger block of masonry. Unlike exfoliation and delamination, spalling is not confined to natural stone, but is also common to brick, and other fabricated masonry materials such as cement products and terra cotta. Spalling is usually caused by the pressure of salts and freeze-thaw cycles of moisture trapped under the surface (subflorescence) which forces off the outer surface or layers of masonry. Spalling can also result from improper laying of stone, exposing bedding planes to weathering and consequent accelerated deterioration, or can be caused by improper repointing techniques utilizing too hard a mortar which does not allow for expansion and contraction of the masonry blocks, thus causing pieces or edges of the masonry blocks to chip or spall off. Improper cleaning techniques, especially abrasive methods, may remove the outer protective layer of brick, terra cotta, or stone, thereby hastening deterioration and spalling of masonry.

Spalling of terra cotta is of two types: glaze spalling and material spalling. Both are the result of air-borne water or water from other sources being trapped behind the glazed surface of the clay. When the water builds up in sufficient pressure to cause expansion of the clay body, the relatively impervious glaze prevents the water from escaping, and the glaze will blister or pop off from the clay surface (glaze spalling), or the clay body itself may fracture or disintegrate (material spalling). Spalling in terra cotta, as in other types of masonry, may also be caused by deterioration of the internal anchoring system which holds the units to the building structure. Water infiltration causes the metal anchors or metal reinforcement to rust which in turn creates increased internal pressure in the masonry units or concrete, resulting in spalling, and potential failure of the structural system if the anchoring fails completely.

Preservation Treatment: See Stucco, p.33; Water-Repellent Coating, p.36; Composite Patching/Plastic Repair, p.50; Consolidation, 52

p.50; Replacement/Patching with Like or Compatible Substitute Materials, p.59.

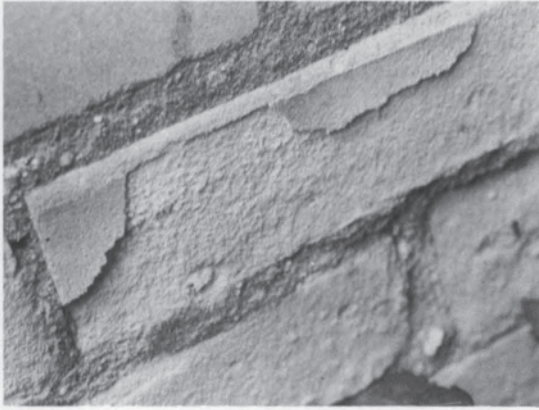

Spalling of brick. Photograph: Susan Dynes.



Glaze spalling of glazed terra cotta. Photograph: John H. Myers.

Subflorescence

Subflorescence is a potentially harmful accumulation, or hidden build-up, of soluble salts deposited under or just beneath the masonry surface as moisture in the wall evaporates. Particularly during the freeze-thaw cycle, the moisture and salts in the wall freeze and expand, building up pressure within the masonry, which, if sufficient, may cause parts of the outer surface of the masonry to spall off or delaminate. External signs of efflorescence may indicate the presence of subflorescence beneath the surface. (Subflorescence is sometimes referred to as cryptoflorescence.)

Preservation Treatment: See Dampproof Course, p. 54.

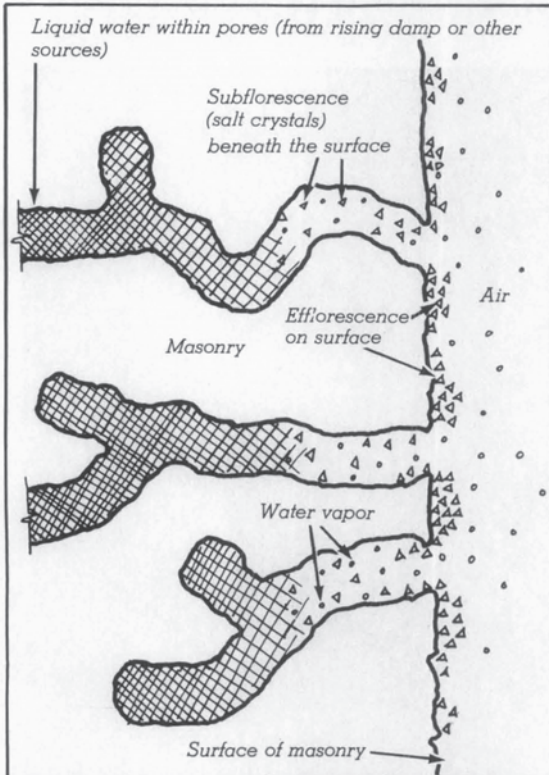

Salts dissolved in water drawn into stone through capillary action evaporate as subflorescence beneath the surface of the stone, and may be evidenced on the stone surface as efflorescence. Illustration: Christina Henry.

Sugaring

A characteristic of some masonry indicative of gradual surface disintegration, possibly caused by salts dissolved in and transported through the stone by moisture and consequent dissolution of the binder. Carbonate stones, especially fine grained marble, are particularly susceptible to this granular, sometimes powdery condition.

Preservation Treatment: See Consolidation, p.52.

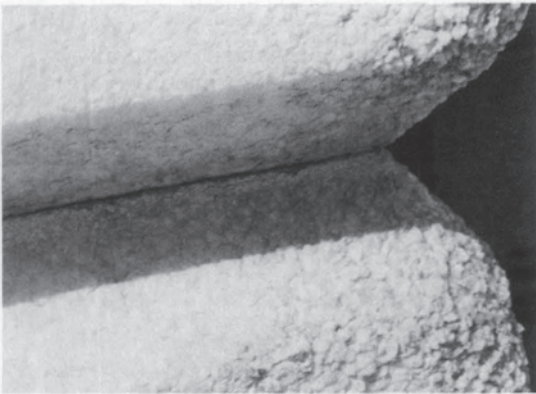

Sugaring of marble. Photograph: Anne E. Grimmer.

Surface Crust/Surface Induration

The movement of moisture toward the surface of stone and the outer edges results in the formation of a hard crust on the surface parallel to the worked surface. Some of these crusts, particularly if they are calcitic in nature, can provide a protective surface to the stone.

Other such crusts resulting from a chemical reaction of the stone to airborne pollutants leading to the dissolution of, and migration of, cementing material from within the stone, may be temporary and, in fact, could be indicative of impending disintegration of the stone (especially sandstone), when the disintegrating block of stone through spalling or exfoliation is itself creating this temporary and superficial surface. (Sometimes this phenomenon is referred to as surface hardened or quarry crust.)

Preservation Treatment: To date, no completely effective treatment has been developed for this condition.

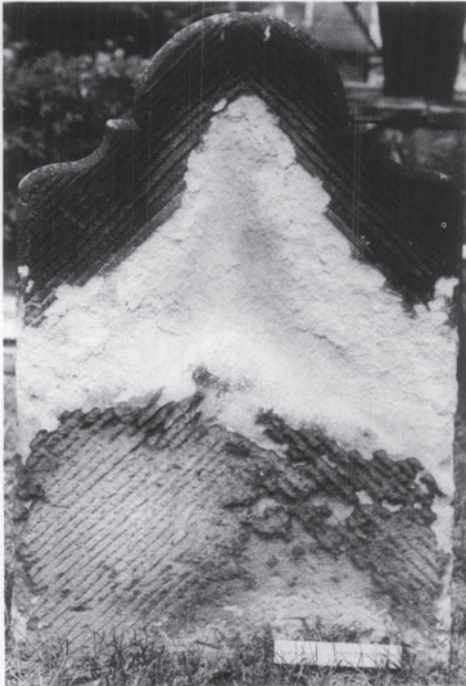

Surface crust on sandstone resulting from dissolution of the stone. Photograph: Erhard M. Winkler.

Weathering

The natural disintegration and erosion of stone caused by wind and rain, resulting in granular and rounded surfaces. Weathering is particularly pronounced on sharp corners, or highly carved or projecting architectural details. Acid rain water in particular, in contact with acid soluble, carbonate stone, can be very damaging, increasing the natural weathering rates, and also resulting in noticeable softening or loss of masonry details.

Honeycomb or alveolar weathering is a type of erosion common to sandstones and limestones, and other non-homogeneous masonry materials. It is characteristic of arid climates, but may also be found in more humid areas. Cavities (alveoles) are created in a honeycomb pattern on surfaces exposed to strong winds where evaporation of salts occurs directly below the surface.

Preservation Treatment: Replacement/Patching with Like or Compatible Substitute Materials, p.59.

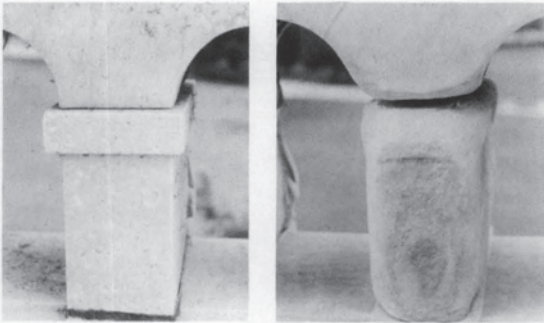

Weathering has reduced the formerly sharp edges and rounded the corners of this marble baluster. Photograph: John H. Myers.

Part 2 Preservation Treatments

The preservation treatments defined in Part 2 are divided into two general categories: *Maintenance* (such as application of surface coatings, caulking and cleaning); and *Repair* (such as consolidation, plastic repair or patching/replacement). *Maintenance* treatments described and illustrated include those basic day-to-day practical and preventive procedures that should be carried out in an effort to preserve historic building material and prevent the need for repairs. *Repair* treatments imply that a greater degree of intervention into the historic fabric is necessary and thus describe and illustrate techniques which must be undertaken when regular maintenance treatments are not adequate to halt deterioration. Often, there simply is no effective preservation treatment that has been developed to date that can be recommended; however, where an appropriate treatment has been developed for a specific masonry problem that is defined and illustrated in Part 1, it is referenced in the Part 2 text.

The reader should be aware that Part 2 includes a number of treatments (such as abrasive cleaning and the application of a water-repellent coating) which are not generally recommended preservation treatments for historic masonry. Such treatments have been included here in an effort to be as comprehensive as possible, and because they may occasionally be recommended preservation treatments, if applied under appropriate professional supervision.

Maintenance

Application of Surface Coatings

Paint

Any pigmented liquid, liquefiable, or mastic composition designed for application to a substrate in a thin layer which is converted to an opaque solid film after application. Paint is generally applied as a protective coating to poor quality or porous masonry to keep out moisture; it may also be used purely for decoration on a historic building.

Paint applied to masonry may be solvent or water based, or may be a masonry paint of a slightly cementitious nature specially formulated with various types of aggregate or thickening agents to smooth rough or uneven masonry walls. Color washes based on lime, such as whitewash, although not technically considered to be paint, and color stains which do not form a film on top of the masonry, but instead penetrate into the masonry substrate, have traditionally provided many of the same benefits as paint.

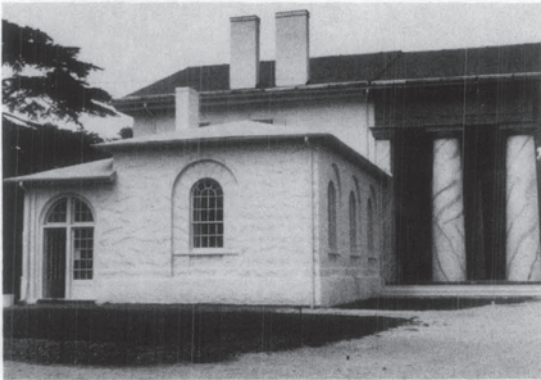

Paint used as a purely decorative aspect to simulate marble on a stucco surface. Photograph: National Park Service.

Parging/Pargeting

In masonry construction, a thin coat of cement mortar (often containing dampproofing ingredients) applied to provide a smooth surface for rough masonry, or as a dampproofing measure for rough masonry, foundation and basement walls. In Great Britian, parging or pargeting describes the traditional decorative plastering of the exterior, including timbers, with a tough lime plaster reinforced with ox-hair and decorated with impressions or patterns made with a mold or comb.



Parging over brick. Photograph: National Park Service.

Stucco

An exterior finish for masonry or frame walls, usually composed of cement, sand, and hydrated lime, which, when mixed with water and applied wet to a surface, adheres to it and subsequently sets or hardens, preserving in a rigid state the form or texture imposed during the period of elasticity. This term was originally used for all plasterwork, but now is generally confined to smooth plastering on the outside of a wall. Stucco was originally made with lime and sand, or gypsum plaster, often with the addition of mud, animal hair or other fibrous material to give color and/or body to the stucco mixture. Stucco is the term given to exterior plasterwork, which in some geographical regions may still be called plaster, in part to differentiate traditional stucco (plaster) from the more common type used today which is composed primarily of portland cement and sand. Historically, stucco was generally smooth surfaced, and often scored to imitate ashlar; however, sometimes rough cast and pebble-dashed surfaces may also be included in the category of stucco.

Rendering is a term frequently used in Great Britain to mean stucco or coats of mortar applied to an external wall to produce a smooth surface and to prevent rain penetration. When referring to exterior or interior plastering, "render" can also mean the first thick or coarse coat of plaster on a wall, usually followed by a second or third finishing coat.

(continued)



Stucco scored to resemble blocks of stone. Photograph: Anne E. Grimmer.

Stucco (continued)

Rendering can also mean the process of applying stucco with a trowel or float.

If **delamination, exfoliation, or spalling** is present, the application of a stucco coating may be an appropriate repair treatment for stone. First, however, try to determine the source of the problem, and eliminate that if possible. While there are no satisfactory treatments known to prevent further spalling, there are a number of repair techniques available which may be successful. Depending on the cause and the degree of severity of the spalling, one option is to cover the deteriorated stone surface with a stucco coating which can be painted and scored to resemble the original masonry material.

Waterproof Coating

These coatings seal the masonry surface from both liquid water and water vapor; they may be clear or opaque—and include bituminous coatings such as those applied to building foundations, and also some paints. They generally do not cause problems as long as they exclude all water from masonry, but if water does enter the wall, the coating can intensify the damage to the wall because the water will not be able to escape. Basically, waterproof coatings make a surface *impervious* to water.



A neoprene coating over a limestone cornice has trapped water (which entered through leaks in the parapet) inside these stone dentils. The built-up water pressure has finally forced the coating to pop off, taking with it pieces of the stone. Photograph: National Park Service.

Water-Repellent Coating

A clear coating which keeps liquid water from penetrating the surface but allows water vapor to enter and leave through the "pores" of the masonry; although usually colorless or transparent (such as silicone coatings), they may change the reflective property of the masonry, and therefore change its visual qualities or appearance. Since these coatings do not seal the surface against water vapor, it can enter and leave the wall. But once inside the wall, the water vapor can condense into liquid water, which will not be able to get back out through the water-repellent coating. Trapped inside the masonry by the water-repellent coating, this liquid water may do considerable damage to interior finishes, or if it freezes, to the exterior. Water-repellent coatings create a surface that *repels* water.

If **spalling** is present, and depending on the cause and the degree of its severity, the application of a water-repellent coating to a *limited* area, may—in some instances—serve to slow down the rate of deterioration. This treatment should only be employed when the masonry is completely dry before the water repellent is applied, when water is prevented from re-entering, and when all other remedial techniques have been investigated. The application of a water-repellent coating will not, however, prevent further spalling and would be, at best, a temporary solution.

A water-repellent or waterproof coating should never be applied to an already damp or wet building which may be likely to have **sub-florescence** under its surface. Such a coating would further prevent the excessive moisture (and dissolved salts) within the wall from evaporating out through the walls, thereby almost ensuring that the walls retain the water and salts, and thus increasing the possibility of spalling.



Water-repellent coating improperly applied gives a blotchy appearance to the stonework. Photograph: Walter Smalling.

Caulking

A resilient (semi-drying or slow-drying) mastic compound, usually of a synthetic composition such as silicone or acrylic, used to seal cracks, fill joints, prevent leaks and, in general, provide weatherproofing and waterproofing. Most caulking materials used today are non-historic materials (i.e., synthetic) and are used primarily in new construction. Caulking should not be used as a substitute for mortar in re-pointing; however, it does have some useful application on historic masonry, to seal between materials of different coefficients of expansion, such as caulking around wood or metal windows on a masonry building.

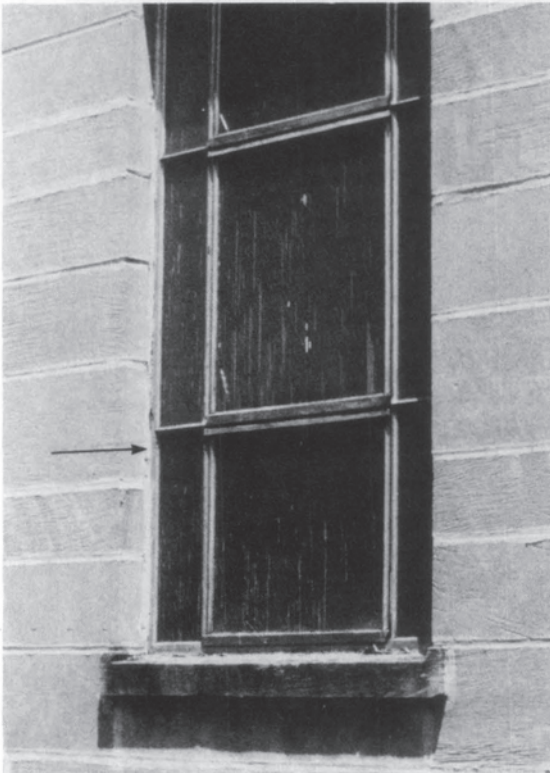

Caulking used as weatherproofing between window frame and masonry wall. Photograph: National Park Service.

Cleaning Methods

Abrasive Cleaning

Abrasive cleaning methods include all techniques that remove soil, discolorations or coatings. Such techniques involve the use of certain materials which impact and abrade the surface under pressure, or abrasive tools and equipment. Sand, because it is readily available, is probably the most commonly used type of grit material. However, many other materials may be substituted for sand and all can be classified, in varying degrees, as abrasive substances: ground slag or volcanic ash, crushed (pulverized) walnut or almond shells, rice husks, ground corncobs, ground coconut shells, crushed eggshells, silica flour, synthetic particles and glass beads, to name a few. Even water under pressure can be an abrasive substance. Tools and equipment that are abrasive and damaging to historic building materials include wire brushes, rotary wheels, power sanding disks and belt sanders. The use of water in combination with grit may also be classified as an abrasive cleaning method. Depending on the manner in which it is applied, water may soften the impact of the grit, but water that is too highly pressurized (over 400 psi) can itself be very abrasive to historic masonry. There are basically two different methods which can be referred to as "wet grit." One technique involves the addition of a stream of water to a regular sandblasting nozzle, done primarily to cut down dust, and has very little, if any, effect on reducing the cutting action of the grit particles. With the second technique, a very small amount of grit is added to a pressurized water stream. This method can be somewhat gentler, its abrasive action controlled by regulating the water pressure and the amount of grit fed into the water stream. Other more euphemistic terms, such as "hydrosilica blasting" or "silica dusting," are used to refer to some abrasive cleaning methods, usually sandblasting. Abrasive cleaning is generally not an acceptable cleaning method for historic masonry buildings except in a few very limited, and carefully controlled situations.

(continued)

Abrasive Cleaning (continued)



Photograph: National Park Service.

Chemical Cleaning

Chemical cleaners for historic masonry buildings are of two types: acidic (low pH) cleaners which are formulated for use on *most* granite, slate, sandstone, and all non-calcareous stones, and unglazed brick; and alkaline (high pH) cleaners which are used on acid-sensitive masonry materials, such as limestone and marble, glazed brick and glazed terra cotta. Common to both types of chemical cleaners is the inclusion of surfactants (organic compounds with powerful properties of detergency and wetting). Acidic cleaners must be removed from the masonry by a thorough water rinse or a "neutralizer." Alkaline cleaners are rinsed off in a two-part process: first they are given a slightly acidic wash, then a thorough water wash.

Although chemical cleaning is generally an acceptable technique for cleaning historic masonry buildings, and certainly the most effective and least damaging method of removing paint, if not carried out with adequate precautions, it can also be damaging to historic masonry. Some of the potential hazards of chemical cleaning include inappropriate or too strong a chemical solution, cleaning during cold weather or when there is a possibility of frost, insufficient rinsing of the masonry after application of the chemical mixture, and environmental or health hazards.



Chemical cleaning to remove urban dirt and pollution from granite without causing damage or abrasion to the surface of the stone.

Photograph: H. Ward Jandl.

Paint Removal

Total paint removal from masonry can usually be accomplished only with the application of chemical paint removers containing either alkalis such as sodium or potassium hydroxide, or organic solvents such as methylene chloride or combinations of other solvents. The dissolved paint is then rinsed from the masonry using a low pressure water wash. Most of these commercially prepared paint strippers also contain a thickening agent or gel that enables the remover to cling to a vertical surface.

Most paints are soluble in organic solvents; paints which have a linseed oil binder are also soluble in alkalis. Some other coatings, such as lime washes (including whitewash or color wash), are soluble in acid. None of these paint removal methods is without problems, however. Both organic solvents and alkalis can be dangerous to cleaning personnel. Organic solvents are expensive, and can also spread stains deeper into the masonry (unless used in poultice form—not always a practical method if removing paint from large areas); alkali-based cleaners can cause efflorescence unless the masonry surface is pre-soaked, and after cleaning, is thoroughly rinsed with water. Sometimes after cleaning the surface must be neutralized by rinsing with a mild acidic solution such as acetic acid, or brownish stains may occur if there are any iron compounds in the stone. Acidic cleaners can also result in efflorescence, or yellow staining, and can cause considerable damage to adjacent shrubbery, metalwork and glass.

Because of the problems inherent in any chemical removal of paint from masonry, it is not advisable to undertake such a project without first weighing the pros and cons of total paint removal, and of course, carrying out tests in an inconspicuous location on the building. Limited paint removal or removal of excess layers of paint or badly peeling paint in preparation for repainting, should be carried out by hand using natural bristle brushes and hand scrapers.

Paint which is significant as a historic finish should not be removed from those buildings which were painted initially or soon after con-

Preservation Treatments

struction, either for aesthetic reasons or to protect inherently poor quality brick.

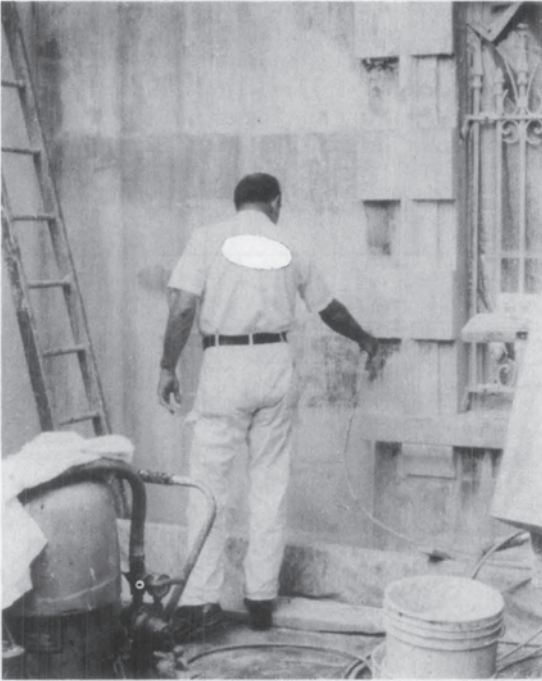

Paint removal from sandstone. Photograph: Baird M. Smith, AIA.

Poulticing

A technique used for cleaning or removal of stains from porous masonry. The principle of poulticing is to draw the stain out of the masonry, to be reabsorbed by the poultice material, while other cleaning methods would just tend to redeposit the stain in the masonry or push it deeper into the masonry. A poultice is composed of an absorbent material, such as

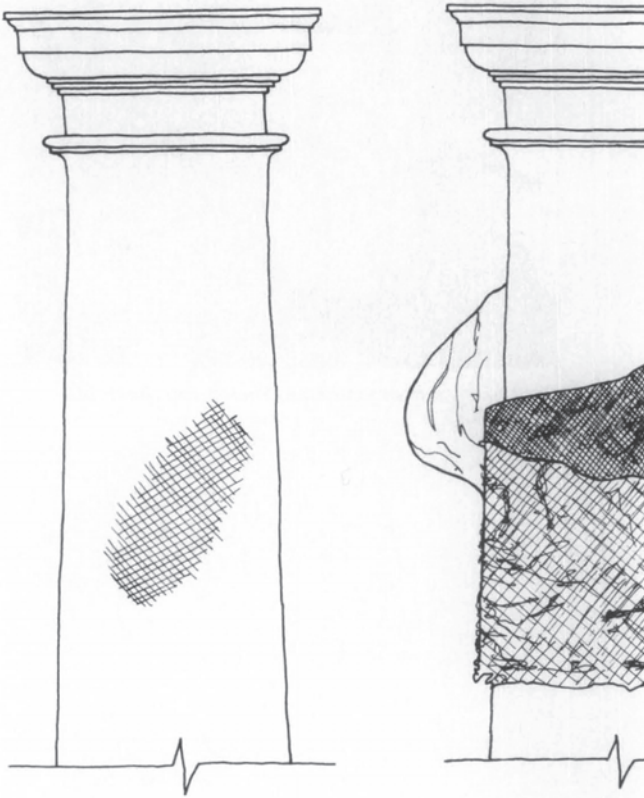

Poultice is applied (saturated with solvent appropriate to remove particular stain). Polyethylene sheet prevents too rapid drying of poultice. After poultice has dried out, the

talc, fuller's earth, whiting, or even shredded paper that has been saturated with a solvent chosen to dissolve the specific type of stain.

Poultices may be successfully applied to remove such stains as: oil, tar, plant materials (lichens and algae), graffiti (including spray paint), metallic stains such as iron and copper, and occasionally, some types of salt deposits or **efflorescence**.

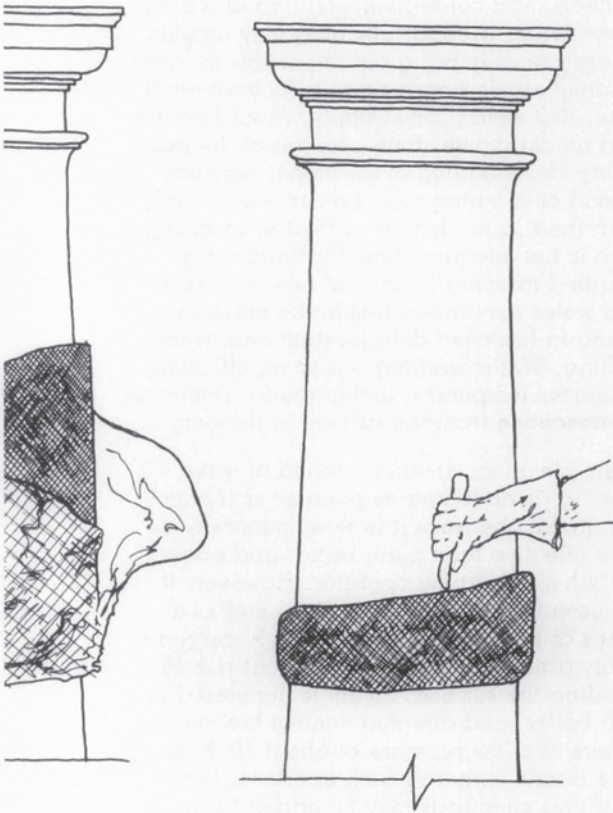

pack is removed carefully by hand with the aid of wooden spatulas. Finally, the column is rinsed with water.
Illustration: Christina Henry.

Water Washing

Water washing may be the most versatile and gentle technique used for cleaning, or dirt removal, from historic masonry buildings. Different water washing methods include: prolonged spraying using a fine mist, high or low pressure washes, steam, water in combination with detergents, and water in combination with chemicals. But even simple water-based cleaning procedures and high pressure (over 400 psi) water blasting can damage historic masonry. The large quantities of water necessary to clean a large structure can seep into the masonry, often causing corrosion of hidden metal elements, and consequent staining of the masonry. Water used for cleaning may contain minerals or may bring out impurities in stone masonry causing permanent discoloration of the stone. Soft water, for example, should not be used on carbonate stone because of the possibility of dissolution of the stone. Any wet method of cleaning must be carried out only when there is no danger of frost or freezing; if there is not adequate time for thoroughly saturated masonry to dry out before a frost, liquid water may freeze inside the masonry, resulting in hastened deterioration and eventual spalling. Water washing is also an effective, if sometimes temporary, technique for removing **efflorescence** from the surface of masonry.

Steam cleaning, another method of water washing, is no longer as popular as it once was, in part because it is slow, generally no more effective than plain water, and poses safety hazards to the operator. However, it is still useful in some stain removal and as a means of removing dirt from highly carved or highly ornamented surfaces without risk of abrading the surface. Steam is generated in a flash boiler, and directed against the masonry surface at a low pressure of about 10-30 psi using a nozzle with a ½ inch aperture. Detergents and chemicals may be added to supplement the cleaning power of the steam.

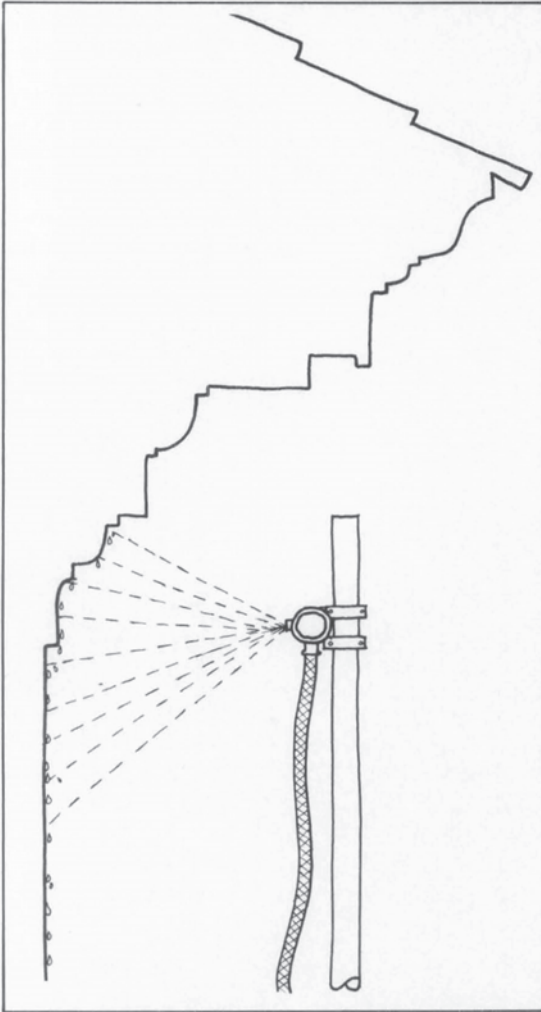

Water washing over an extended period of time using a fine spray or mist to gently soften areas of heavy dirt deposit. Water is sprayed through holes of a pipe or hose suspended from above area being washed. Illustration: Christina Henry.

Composite Patching/ Plastic Repair

A repair treatment carried out by patching selected areas of deteriorating masonry with a cementitious material. Plastic repair can be quite successful if limited to small cavities or small areas of missing stone (no larger than 1-3 inches deep). If carried out by a skilled workman, plastic repair can sometimes be less obtrusive than a replacement in natural stone, and much cheaper. Mixes vary according to the type of masonry being repaired, but are based on a cementitious mix, and should always be weaker than the masonry being repaired. Sand and/or crushed stone is the usual aggregate. Some artificial coloring may be needed to make the patch blend in with the historic masonry, but it may reduce the strength of the repair and the color may fade. While larger patches may seem to require ad-

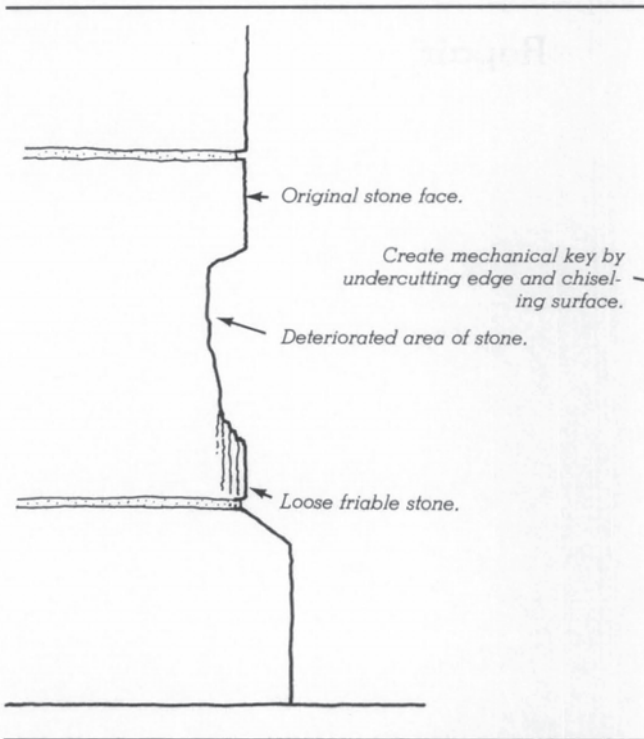

ditional support, in the form of stainless steel or polyester pins or anchors, use of such supplementary devices is not always very satisfactory. Successful composite patches should match the stone in color and texture, replicate surface tooling, adhere well to the stone substrate, and should not cause deterioration of surrounding stone. In comparison with natural stone, plastic repairs can look rather dull and lifeless, and for this reason also, should be used only in small areas; however, such repairs can sometimes be painted to match adjacent areas of masonry. If composite patching or plastic repairs are carried out using too hard a mix, they may not adhere, or may accelerate weathering and deterioration of the adjacent natural stone, partly because of the different rates of expansion. This type of repair may also be referred to as dental repair, and is sometimes appropriate for **delamination, exfoliation, or spalling.**

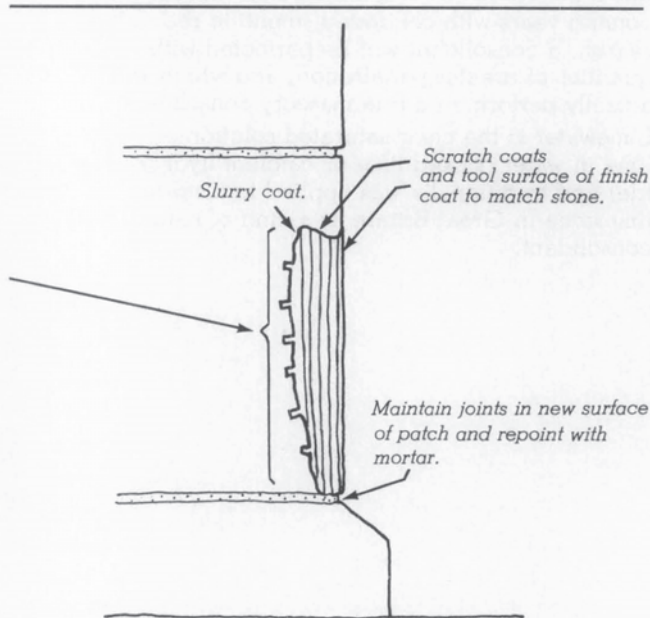

Shape cementitious patching material to match original profile of stone. Maintain joints in new patched surface and repoint with mortar. Illustration: Christina Henry.

Consolidation

Consolidation is a process carried out in a effort to strengthen masonry, particularly natural stone and concrete and is generally undertaken in an attempt to bring back together or consolidate deteriorating or disintegrating masonry (through **crumbling, friability, spalling,** or loss of binder in **sugaring**). Consolidation generally involves application of an inorganic substance such as barium hydroxide or injection of some type of a chemically-curable monomer such as methyl methacrylate and n-butyl methacrylate or a clear silicone polymer such as the group of silanes, silicones, alkoxy silanes, and silicone esters. Silicone surface coatings, wax or other water-repellent coatings are also often tried as consolidants—often without success. The difficulty or near impossibility of achieving a deep enough penetration or impregnation of the masonry with a consolidant makes the application of consolidants of somewhat dubious value at this time. However, it is anticipated that in coming years with continued scientific research, a consolidant will be perfected with qualities of greater penetration, and which will actually perform as a true masonry consolidant. Limewater is the clear saturated solution of lime in water (slaked lime or calcium hydroxide) and traditionally was applied to historic limestone in Great Britain as a kind of natural consolidant.

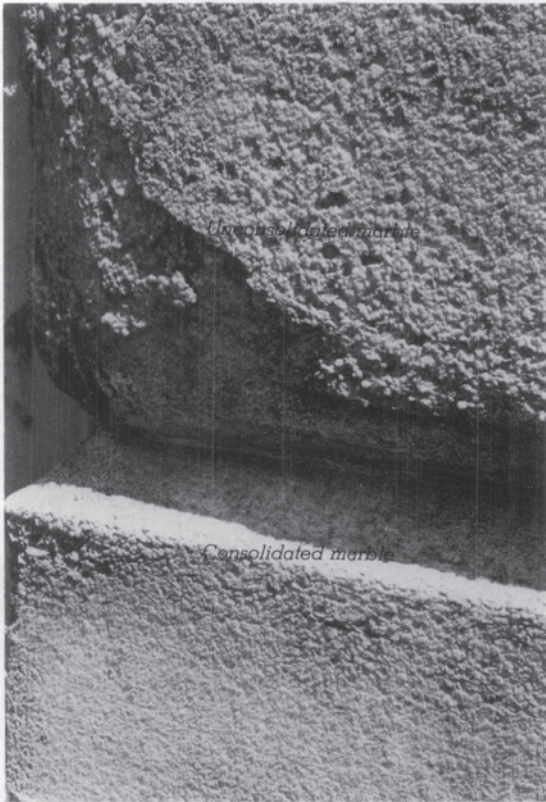

A barium hydroxide consolidant (nearly invisible in the photograph) has been applied here in an attempt to consolidate this sugaring marble. Photograph: Christina Henry.

Dampproof Course

Installation in masonry of a horizontal layer of material which is impervious to water, such as tile, slate, lead-cored bituminous sheet or bituminized felt, polyethylene sheeting, or metal, to prevent the capillary rise of moisture—**rising damp**—from the ground into the masonry wall. Historically, some masonry buildings were constructed with a dampproof course, but usually dampproof courses must be added later as a remedial measure to correct problems caused by rising damp. A traditional dampproof course is not installed without difficulty, as a continuous horizontal course must be cut out of the mortar or brick at a level just above the ground and below first floor joists, and the dampproofing material inserted in an uninterrupted horizontal course. This system



The horizontal row of white dots in the brick headers indicates that a chemical dampproof course has been injected. Photograph: Baird M. Smith, AIA.

can be utilized on walls that are regularly coursed and stable. If the mortar is severely deteriorated, the wall may be too unstable to cut out the joint without dislodging masonry units above. For walls more than eight inches thick, it may be necessary to work from both sides. Because of the difficulty of inserting this type of dampproofing, in recent years other techniques have been devised such as injection of a chemical dampproof course, insertion of a synthetic or plastic course, and a system based on electro-osmosis to create a dampproof barrier.

Some type of dampproofing treatment may be necessary to minimize **subflorescence**, or to eliminate the source of moisture which is carrying harmful salts into the building.



Dutchman Repair

This type of partial replacement or "piecing-in" can be done either with natural stone or with a pre-cast imitation as a treatment for **chipping** stone. It involves replacing a small area of damaged stone with a new unit. The new stone is either wedged in place or secured with an adhesive. The joint between new and old should be kept as narrow as possible to maintain the appearance of a continuous surface.

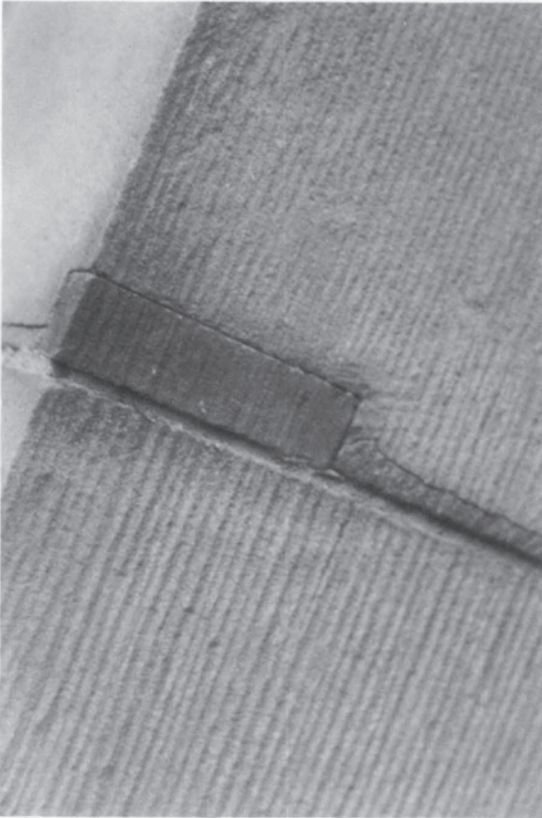

Dutchman repair using sandstone to match original tooled sandstone. Photograph: Anne E. Grimmer.

Epoxy Repair

Repair carried out by patching selected areas of deteriorating masonry using an epoxy mixture, which is part of a class of synthetic, thermosetting resins which produce tough, hard, chemically resistant coatings and excellent adhesives. Epoxy resins can be used for repairing broken stones, and are particularly good for putting back together small, carved or other decorative details. Epoxies can also sometimes be used to repair small defects, imperfections, or thin pieces of detached stone by veneering or "gluing" on new replacement pieces.

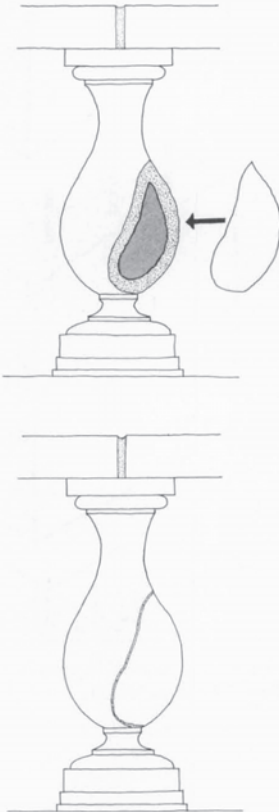

*Epoxy repair of broken terra cotta baluster in which epoxy is applied to the break. The broken piece is reattached and the joint smoothed so repair is not visible.
Illustration: Christina Henry.*

Mechanical Repair

This treatment may be defined as the use of cutting back, drilling, reinforcement pinning, and grouting methods to fasten together fractured masonry. This type of repair may be appropriate for use on the following kinds of deterioration: **cracking, delamination, detachment,** and **exfoliation.** Each of these problems merits a slightly different variation of mechanical repair.

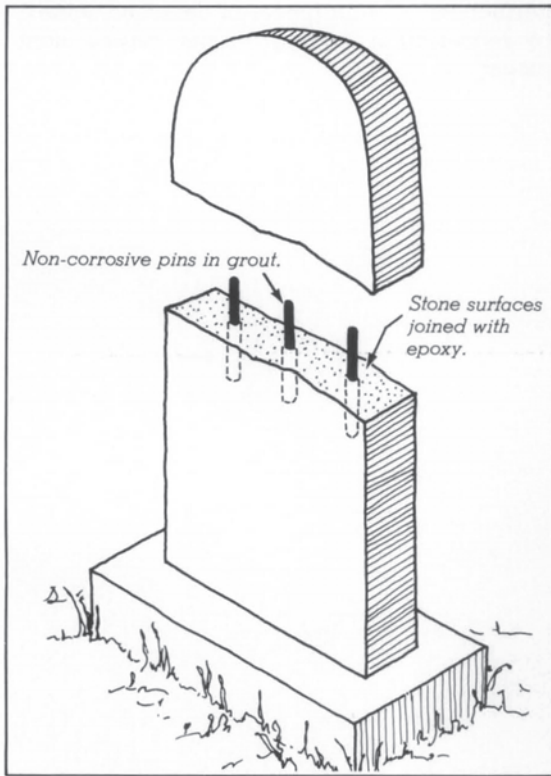

Mechanical repair of detached tombstone using grout and pins. Illustration: Christina Henry.

Replacement/Patching with Like or Compatible Substitute Materials

The replacement of missing, broken, cracked or otherwise deteriorated historic masonry units with a new piece or pieces of the same material, such as stone, terra cotta, brick or adobe. This repair technique is generally preferable to repair with a non-matching or synthetic material, if suitable matching materials are available.

Areas of adobe that have been subject to **coving** should be patched with adobe, using clay with a texture and color close to the original, after improving the drainage and eliminating, if possible, the moisture problem. **Cracking** in adobe may be repaired using a procedure similar to repointing. It is necessary to rake out the cracks to a depth of 2 or 3 times the width of a mortar joint to obtain a good "key", and patch with adobe mud.

(continued)

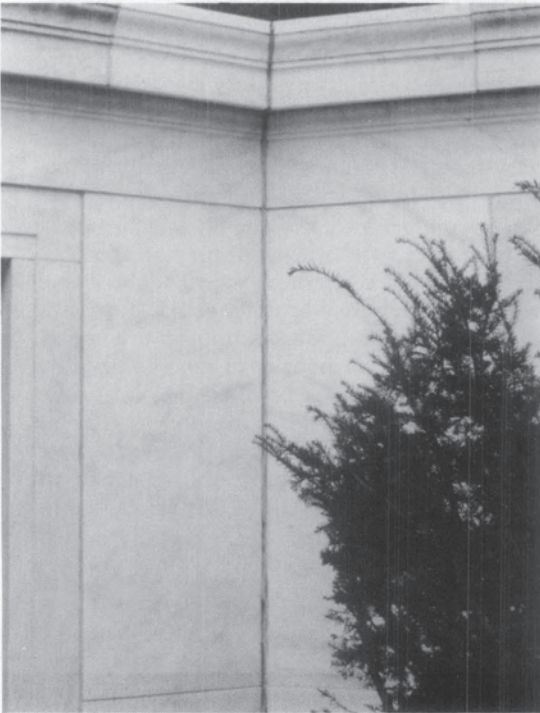

The two sections in the center have been replaced with marble matching the original. Photograph: Anne E. Grimmer.

Replacement/Patching (continued)

Once stone **delamination** or **exfoliation** has begun, there are at this time no methods of consolidation or of preventing further deterioration known to be completely successful. If the degree of delamination is only slight, it may be best to leave the stone as it is. In some instances however, there are several primarily cosmetic repair techniques which may be successful. If the block of stone is thick enough (and does not have decorative detailing), one method is to cut back the delaminating layers to sound stone, or another approach might be to remove the delaminating stones, then reverse and replace them on the facade. If these techniques are not feasible, it may be necessary to replace the deteriorating stone, either with matching stone, or a stone-like substitute (such as precast concrete or cast stone); or patch individual stones with a cementitious mixture; or cover the deteriorating stone facade with a stucco coating and scoring the surface to resemble blocks of stone, after cutting back to sound stone. Individual masonry units, badly damaged or disfigured by **chipping**, **erosion**, or **weathering**, may have to be replaced with a matching masonry material, an appropriate substitute material, or patched with a cementitious mixture. Like delamination, there are no satisfactory treatments known to prevent further **spalling**, but there are a number of repair techniques available which may sometimes be at least temporarily successful. Depending on the cause, and the degree of severity of the spalling, there are a number of options. If deterioration is severe, the historic masonry can be resurfaced with natural stone or brick veneer; or the deteriorated masonry units patched with like or compatible substitute materials (such as cast stone or concrete).

Repointing/Tuckpointing

Repointing, or tuckpointing, is the process of removing deteriorated mortar by hand from the joints of a masonry wall to a depth of 1/2 to one inch, replacing the deteriorated mortar with new mortar, and finishing the joints with a profile to match the original. Ideally, repointing mortar should duplicate the original as closely as possible. This frequently means using a soft, high-lime content mortar that is softer (measured in compressive strength) than the bricks or stone and no harder than the historic mortar. Repointing mortar for most historic buildings (constructed before the 20th century) should ideally be composed only of lime and sand in water. White portland cement may be substituted for up to 20% of the lime to achieve workability or plasticity without adversely affecting the most desirable qualities of lime mortar. It may also be necessary to add pigment, crushed shells or colored sand to achieve a mortar that resembles the original.

In British usage, tuckpointing refers to a method of pointing in which a lime putty or

(continued)

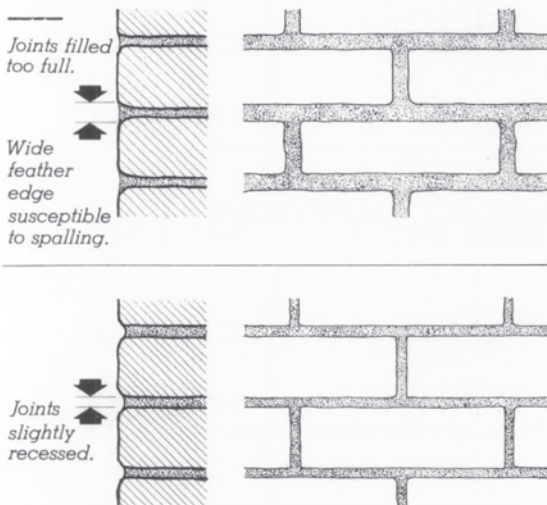

Comparison of visual effect of full mortar joints vs. slightly recessed joints. Filling joints too full hides the actual joint thickness and changes the character of the original brickwork. Illustration: National Park Service.

Repointing/Tuckpointing (continued)

mortar (white or black) is placed over a regular mortar joint as a decorative treatment to give the illusion of very fine joints.

Use of a scrub coating or face grouting is generally not an appropriate treatment for historic masonry and should not be substituted for repointing.

Selected Reading List

- Amoroso, Giovanni G., and Vasco Fassina. *Stone Decay and Conservation: Atmospheric Pollution, Cleaning, Consolidation and Protection*. Materials Science Monographs, 11. Amsterdam, The Netherlands: Elsevier Science Publishers B. V., 1983.
- Ashurst, John, and Francis G. Dimes. *Stone in Building: Its Use and Potential Today*. London: The Architectural Press, Ltd., 1977.
- Berryman, Nancy D., and Susan M. Tindall. *Terra Cotta: Preservation of an Historic Building Material*. Chicago: Landmarks Preservation Council of Illinois, 1984.
- Borchelt, J. Gregg (compiler). "Glossary of Masonry Terms." *The Masonry Society Journal*. Vol. 1, No. 1 (January - June 1981), pp. G13-G21.
- Brunskill, Ronald, and Alec Clifton-Taylor. *Brickwork*. London: Van Nostrand Reinhold Company, 1982.
- Clark, Elizabeth J., Paul G. Campbell, and Geoffrey Frohnsdorff. *Waterproofing Materials for Masonry*. NBS Technical Note 883. National Bureau of Standards, U.S. Department of Commerce, Washington, D.C.: 1975.
- Conservation of Historic Stone Buildings and Monuments*. Report of the Committee on the Conservation of Historic Stone Buildings and Monuments. Washington, D.C.: National Academy Press, 1982.
- Construction Dictionary: Construction Terms and Tables*. Phoenix: Greater Phoenix, Arizona Chapter #98 of The National Association of Women in Construction, 1981.
- Davey, Andy, Bob Heath, Desmond Hodges, Roy Milne, and Mandy Palmer. *The Care and Conservation of Georgian Houses: A Maintenance Manual*. London: The Architectural Press, with Edinburgh New Town Conservation Committee, revised 1980.
- Fielden, Bernard M. *Conservation of Historic Buildings*. London: Butterworth & Co., 1982.
- Gilder, Cornelia Brooke. *Property Owner's Guide to the Maintenance and Repair of Stone Buildings*. Technical Series/No. 5. Albany, New York: The Preservation League of New York State, 1977.
- Harris, Cyril M. (ed.). *Dictionary of Architecture and Construction*. New York: McGraw-Hill, Inc., 1975.
- International Masonry Institute. *The Masonry Glossary*. Boston: CBI Publishing Company, Inc., 1981.

- Lynch, Michael F., and William J. Higgins. *The Maintenance and Repair of Architectural Sandstone*. New York: New York Landmarks Conservancy, 1982.
- Matero, Frank G., and Jo Ellen Freese. "Notes on the Treatment of Oil and Grease Staining on a Masonry Surface." *Association for Preservation Technology Bulletin*, Vol. X, No. 2 (1978), pp. 132-141.
- McKee, Harley J., FAIA. *Introduction to Early American Masonry: Stone, Brick, Mortar and Plaster*. National Trust / Columbia University Series on the Technology of Early American Building 1. Washington, D.C.: National Trust for Historic Preservation and Columbia University, 1973.
- Preservation Briefs*, National Park Service, Department of the Interior, Washington, D.C.:
1. *The Cleaning and Waterproof Coating of Masonry Buildings*. Robert C. Mack, AIA. November, 1975.
 2. *Repointing Mortar Joints in Historic Brick Buildings*. Robert C. Mack, AIA, de Teel Patterson Tiller, and James S. Askins. August, 1980.
 5. *The Preservation of Historic Adobe Buildings*. August, 1978.
 6. *Dangers of Abrasive Cleaning to Historic Buildings*. Anne E. Grimmer. June, 1979.
 7. *The Preservation of Historic Glazed Architectural Terra-Cotta*. de Teel Patterson Tiller. June, 1979.
- Scott, John S. *A Dictionary of Building*. Baltimore: Penguin Books, Ltd., 1969.
- Sleater, Gerald A. *A Review of Natural Stone Preservatives*. NBSIR 74-444. Center for Building Technology, Institute for Applied Technology, National Bureau of Standards, U.S. Department of Commerce, Washington, D.C.: 1973.
- _____. *Stone Preservatives: Methods of Laboratory Testing and Preliminary Performance Criteria*. NBS Technical Note 941. Center for Building Technology, Institute for Applied Technology, National Bureau of Standards, U.S. Department of Commerce, Washington, D.C.: 1977.
- Strangstad, Lynette. "Patching Limestone and Marble: A Step-by-Step Guide." *The Old-House Journal*. Vol. X, No. 7 (July 1982), pp. 133, 143-147.
- _____. "Patching Brownstone." *The Old-House Journal*. Vol. X, No. 8 (August 1982), pp. 161-164.

- Weaver, Martin. "Cleaning Masonry: A Look at Water and Chemical Treatments." *Canadian Heritage* (December 1981), pp. 39-42.
- Weiss, Norman, Jeanne Teutonico, Frank Matero and Raymond Pepi. *Sandstone Conservation Study*. Sponsored by the New York Landmarks Conservancy, with a matching grant-in-aid from the Department of the Interior through the New York State Office of Parks, Recreation and Historic Preservation. Unpublished manuscript and undated (c. 1981-82).
- Winkler, E. M. *Stone: Properties, Durability in Man's Environment*. New York: Springer-Verlag, 1973.

See discussions, stats, and author profiles for this publication at: <https://www.researchgate.net/publication/282662395>

Striegel, Mary F., and Jason W. Church. "Best Practice Recommendations for Cleaning Government Issued Headstones." Natchitoches, Louisiana: National Center for Preservation Technol...

Technical Report · May 2011

CITATIONS
0

READS
24

2 authors:

 **Mary Striegel**
Northwestern State University
10 PUBLICATIONS 155 CITATIONS
[SEE PROFILE](#)

 **Jason W. Church**
National Park Service
2 PUBLICATIONS 0 CITATIONS
[SEE PROFILE](#)

Some of the authors of this publication are also working on these related projects:

 Resilience of Traditional Materials to flooding [View project](#)

 Graffiti Removal [View project](#)

All content following this page was uploaded by [Mary Striegel](#) on 18 November 2015.

The user has requested enhancement of the downloaded file.



Best Practice Recommendations for Cleaning Government Issued Headstones¹

This document was developed as general guidance for the cleaning of government issued headstones based on research undertaken by the National Park Service National Center for Preservation Technology and Training and funded by the Department of Veterans Affairs National Cemetery Administration. Recommendations are intended to be used by cemetery directors, operations staff, foremen, maintenance staff, contractors and headquarters staff. The document focuses on general cleaning and regular maintenance of marble headstones that are soiled from dirt and biological growth. Recommendations do not address cleaning needs from unusual events such as removal of road tar, mower scars, vandalism, or other accidental damage. Cleaning recommendations for other stone types such as granite, sandstone, or limestone are not presented here.

One of the critical components of maintaining the appearance of a national cemetery is the cleaning of headstones. Many of the more than 3 million gravesites in 131 national cemeteries are historic headstones and markers which should be protected and treasured. Also, today's new headstone will be tomorrow's historic grave marker.

Headstone cleaning must take into consideration the operational standards set forth by the National Cemetery Administration. [1] The following standards are among those designated for headstones:

- Headstones, markers, and niche covers are clean, free of debris and objectionable accumulations.
- Headstones, markers, and niche covers are not damaged by cemetery operations (e.g., interment, grounds maintenance, headstone, marker, niche cover, maintenance, and facility maintenance operations).

Maintenance practices must have an eye toward the future. Many cleaning methods may be able to remove soiling from headstones. Some will be more effective than others. But the long-term effects must also be considered. Anyone developing a cleaning method must look at the soiling agent to be removed, the potential threats caused by the soiling, and the possible unintended results of cleaning.

¹ This document, released for distribution on May 23, 2011, is part of a forthcoming report of research undertaken by the National Park Service's National Center for Preservation Technology and Training for the Department of Veterans Affairs National Cemetery Administration.

Soiling Agents or Accumulations

Soiling agents are accumulations on stone that alter the appearance of the stone and may cause additional damage. Different soiling agents may respond better to a particular cleaning method. Soiling agents include:

- **Dirt**, including soil and mud, often arises from transferring the topsoil to headstone surface. Dirt can lead to dark staining on the surface or an overall dingy appearance. Dirt can penetrate into the pores of the stone and be difficult to remove. Minerals containing iron can leach into the marble surface and leave rust colored stains behind. If the headstone has sunk into the ground over time, then is raised and realigned, a distinct line of soiling can be seen. Dirt can retain moisture after rainfall and lead to the growth of mold or mildew on the stone surface.
- **Air pollution**, including particles from vehicle exhaust, can deposit on the surface of marble. Nearby factories or industrial activities can generate pollutants that can change the appearance of the stone or chemically interact with the stone over time. For example, sulfur dioxide produced through manufacturing processes and vehicle exhaust can interact with marble surfaces to cause gypsum crusts. These crusts can capture soil and pollution particles to create rough, gray surfaces.[2]
- **Biological organisms**, such as bacteria, mold, mildew, algae, mosses, or lichen can adhere to the headstone and result in appearance changes. Microorganisms are capable of establishing a biofilm on the surface of the stone. Biofilms include proteins and sugars that are hard to remove through standard cleaning practices and provide food for regrowth of organisms.[3] Bacteria can consume air pollutants and produce acids that can attack the stone. Fungi can penetrate the pore system of stone and carry bacteria further into the stone.[4]
- **Bird droppings** or other animal secretions can stain the stone. Depending on the animal's diet, the stains may be difficult to remove. Urine seeps into porous materials and with time produces yellow stains.
- **Plant or tree sap** is a sticky substance that drips from overhanging trees. The material may contain resins that are not easily dissolved in water. The sugars in the sap may attract insects or provide food for molds and mildews. Shrubs have falling berries that can stain surfaces.

Other threats to headstones

- **Salt damage** can cause disintegration of a stone surface. The presence of salts within the stone, in the grounds surrounding the stone, in irrigation water, in some herbicides, and in some cleaners, can migrate through the stone's porous network and cause damage. Salts are dissolved and transported by water. They can recrystallize and exert pressures in the pores that may exceed the strength of the stone.[5, 6] Thus, do not use cleaners that leave behind salts to clean marble headstones.
- **Freeze thaw cycles** can increase stone weathering. Water can enter into openings, cracks, and pores of stone. If freezing temperatures exist, the water can freeze and expand. With many freeze thaw cycles, water can damage stone.[7] Since most cleaning efforts require saturating the stone with water or liquids, do not clean headstones during freezing temperatures or when a freeze is expected within 48 hours of the cleaning.
- **Improper cleaning** can stain the surface or accelerate stone deterioration. Well-meaning but ill-informed custodians of cemetery headstones do damage through poor selection of cleaning methods. This would include use of power-washing equipment too close to the stone, not rinsing after application of cleaner, and using products in a greater strength than the manufacturer recommends.

Important factors to consider

- **Use the gentlest, least invasive method**
Select cleaning methods and materials that, to the best of your knowledge, do not affect the headstone. Chemicals and physical treatments should be undertaken using the gentlest means possible to insure the longevity of the headstone and to minimize the need to replace the stone.
- **Do no harm to the stone**
Do no harm to the headstone during its care or the care of the cemetery. A headstone is placed on a soldier's grave as a marker to identify burial site, but serves other roles as well. It is intended to honor the deceased and thus should be treated with respect. Over time the headstone takes on meaning to the loved ones who visit. By its very nature, it possesses added value and association to the veteran's service.

- ***Consider long-term effects***

Recognize that cleaning efforts are part of a continuum of cleaning that will be applied to the headstone. All efforts to clean headstones affect the surface in ways that are not always obvious. Marble is made up of interlocking grains of carbonate mineral which is bound together in a network that includes varying amounts of pores. When the surfaces are cleaned, some of the grains can be loosened and lost. Sometimes the mineral binder that holds the stone together can be affected. Over time and many cleaning campaigns, the surface can be altered noticeably and result in a sugaring appearance. Some marble is more prone to this type of deterioration than others. For example, Colorado Yule marble is more affected by cleaning than Cherokee White marble from Georgia.
- ***Don't remove the original surface***

The original surface may be polished and smooth. The inscriptions are generally carved into the headstone. If the original surface is altered, the way the headstone subsequently weathers may be changed. As the surface roughens, it will soil more easily. The inscriptions can be eroded away, making the headstone harder to read. Never aggressively scrub the surface, or use wire brushes or mechanical methods such as sanders or grinders to clean the surface. See also –mechanical cleaning: power tools, below.
- ***Minimize cleaning impacts***

Minimize the number of times a headstone is cleaned in its lifetime. While a cyclic maintenance plan is needed to maintain the appearance of the headstone, over-cleaning should be avoided. If possible, historic headstones should not be cleaned more frequently than once a year.
- ***Test cleaner first***

ALWAYS TEST the cleaner for suitability and results before overall cleaning. Conduct the test using the recommended application procedures. Let test area dry thoroughly before inspection. When using a biocidal cleaner, it may take several days before the full cleaning effect is realized. When practical, allow two or more weeks for biological soiling to disappear.

- ***Consider Environmental Conditions***

Environmental conditions may dictate the frequency of cleaning. For example, headstones that are located in shady and damp areas under trees may need to be cleaned more frequently than headstones in sunny areas.

Cleaning techniques known to damage stone

- ***Bleach or bleach-like products***

Household bleach or other oxidizing cleaners, such as Daybreak cleaner or HTH Shock 'N Swim pool treatment may chemically react with the stone surface and leave soluble salts in the pores of the stone which will lead to decay. Check the label of the cleaner or the Materials Safety Data Sheet (MSDS) for active cleaning ingredients. If the products contain sodium hypochlorite (NaClO), sodium perborate, sodium percarbonate, sodium persulfate, tetrasodium pyrophosphate, calcium hypochlorite or urea peroxide, do not use them for cleaning the headstone. For example, Daybreak cleaner contains 14% sodium hypochlorite and is not recommended.

- ***Strong acids or bases***

Strong acids, including muriatic acid, hydrochloric acid, or others are too harsh and will dissolve the stone surface. Because they are corrosive, they can also be hazardous to workers. Strong bases, such as concentrated ammonia, sodium hydroxide, calcium hydroxide, potassium hydroxide, or others may be aggressive on the surface of the stone and may be hazardous to workers.

- ***Mechanical cleaning: Power tools***

Harsh mechanical devices such as sand blasting, or power tools such as sanders or drills equipped with a wire brush remove the original material of the grave marker.

- ***Mechanical cleaning: High-pressure washing***

Pressure washing systems are mechanical sprayers that use water under high pressures to clean surfaces. Commercially available pressure washers operate at pressures between 750 psi and 30,000 psi that will damage marble headstones. This technique can cut into and mar the surface of the stone. The appropriate distance and pressure needed to properly clean an individual headstone is generally about 12 inches with a pressure of 500 psi or less. Some stones may not be able to tolerate these conditions depending on their condition. A test patch in a small unobtrusive area on the headstone is recommended prior to cleaning.

Cleaning methodology

A cleaning regimen for headstones should be based on environmental considerations such as humidity, biological growth rates, tree cover and vegetation, precipitation and other factors that influence the frequency of cleaning necessary to maintain an appropriate appearance.

- ***Choosing the cleaner***

Cleaning should be undertaken with the mildest, least-abrasive method. Improper cleaning can lead to accelerated deterioration or loss of original materials. Always begin by reviewing the Materials Data Safety Sheet (MSDS) for any chemical product to be used. The MSDS may be found by searching online or by contacting the manufacturer or distributor. The MSDS contains important chemical information and necessary safety precautions needed for use of the product.

Make sure to note the manufacturer's application recommendations. The two most important features to note are the dilution ratio and the dwell time. If the manufacturer recommends diluting the cleaner, use the recommended dilution ratio. A small amount of the cleaner should be added to water to create the required ratio. Using the cleaner in a more concentrated form may increase the risk of damage to the headstone. The dwell time is the amount of time that the cleaner is left on the surface of the stone before scrubbing and rinsing the stone. The dwell time varies depending on the cleaner.

Biocidal cleaners are available for use on stones that have biological growth, such as algae, mildew, moss, and lichen. Most biocidal additives also help to keep biological from returning to the stone for an extended period of time. Recommended biocidal cleaners include D/2 Biological Solution manufactured by Sunshine Makers,² Enviro Klean® BioWash®,³ or other cleaners that contain quaternary ammonium compounds. Consult with the product manufacturer to determine if the biocidal cleaner contains buffers that may leave salts behind on the stone. Follow directions as specified by the biocide manufacturer, making sure to rinse thoroughly. It is important to know that marble cleaned with biocides should continue to lighten over the next few days. The advantage of a biocidal cleaner is that it helps remove a wide range of soiling including

² Exclusively distributed by Cathedral Stone® Products, Inc., 7266 Park Circle Drive, Hanover, MD 21076, Telephone: 410-782-9150, Fax: 410-782-9155.

³ Manufactured and distributed by PROSOCO, Inc., 3741 Greenway Circle, Lawrence, KS 66046. Telephone: 800-255-4255; Fax: 785-830-9797. E-mail: CustomerCare@prosoco.com.

biological growth. The disadvantage is that the cleaners are more expensive than other products on the market.

- ***Equipment needed***

- Personal Protective Equipment*

- While no special equipment is required under normal use, gloves and eye protection are recommended. Avoid eye contact where splashing of the cleaner may occur, such as during spray applications. Wash hands thoroughly after handling any cleaner and before eating, drinking or smoking.

- Brushes*

- Soft bristle brushes are required when cleaning stones. They can have natural or synthetic bristles. Vegetable brushes or soft grooming brushes for large animals are a few that can be found in chain or farm supply stores. All rough or metal edges must be covered with tape to reduce the chance of scratching the stone.

- Hand or Backpack Sprayers*

- A variety of hand-pump sprayers can be used for cleaning headstones. Make sure that the sprayer is dedicated to the cleaners to be used and not used for other functions like applying pesticides. Backpack sprayers are useful when cleaning a large number of headstones typical in the national cemeteries. These consist of a holding tank, hose, and wand with adjustable nozzle. The sprayers generally operate in a 15-80 psi pressure range.

- Clean Water*

- One of the most important things to locate in the cemetery is the nearest source of water. It takes a lot of water to properly clean stone. If the cemetery does not have clean running water then it is important to bring barreled or bucketed water to the site.

- ***Pre-wetting the stone***

- Soak the stone liberally with water before applying the cleaner with a hand or backpack sprayer. Stone is a very porous material and will absorb the cleaner. By soaking it beforehand, the cleaner will stay on the surface of the stone and minimize penetration of the cleaner in to the stone. This action minimizes potential adverse effects by the cleaner, such as salt crystallization in the pores of the stone. It makes it easier to rinse the cleaner from the stone surface.

- **Applying the cleaner**
Always keep the stone wet during cleaning and thoroughly rinse afterwards. Do not allow the cleaner to dry on the stone. Apply the cleaner according to the manufacturer's recommendations. Changes to the dilution or dwell time are considered "off-label" and the effectiveness of the cleaning method cannot be guaranteed. Evenly apply the cleaner with a sprayer to saturate the surface.
- **Agitating the surface**
Agitate the surface gently in a circular motion using a soft bristle brush. Work in small areas, starting from the bottom and moving toward the top of the headstone. Agitation will loosen soiling from the surface of the stone.
- **Rinsing the stone**
Remember to rinse after cleaning each area and to thoroughly rinse the stone at the end to make sure that no cleaner is left behind.

A typical cleaning regime may include a three-person team. The first person thoroughly wets the stone with clean water using a hose or a portable backpack sprayer. A second person sprays the stone surface with the biocidal cleaner. After the appropriate dwell time, a third person gently agitates the cleaner on the stone surface with a soft bristle brush, then rinses the stone with clean tap water.

Glossary of Terms

Ionic cleaner: A substance that aids in the removal of dirt and serves as an emulsifier by bridging between water and oil. The substance is a long chain chemical that has a charge on one terminal.

Non-ionic cleaner: A substance that is similar to an ionic cleaner, except that it does not have a charge.

Surfactant: A compound that is a surface active agent. It reduces the surface tension between liquids that do not normally mix together. It aids in the cleaning of a surface.

Biocide: A chemical capable of killing living organisms.

Pressure washer: a mechanical sprayer that uses high-pressure water to clean and remove dirt and other accretions from surfaces and objects.

Dilution ratio: reduction of the concentration of a chemical by mixing with water or another solvent by a specific portion. A useful reference chart for specific dilution ratios can be found at http://www.tomorrowchemicals.com/files/Dilution_Ratios_TC.pdf.

Dwell time: The time a cleaner remains on the surface of a stone before agitation or rinsing.

References

1. *National Cemetery Administration, National Shrine Commitment, Operational Standards and Measures*. October 2009, Department of Veterans Affairs: Washington, DC. p. 32.
2. Charola, A.E., *Review of the Literature on the Topic of Acidic Deposition on Stone*. 1998, NCPTT Publication 1998-09: Natchitoches, La. p. 85.
3. Hall-Stoodley, L., J.W. Costerton, and P. Stoodley, *Bacterial biofilms: from the Natural environment to infectious diseases*. *Nat Rev Micro*, 2004. **2**(2): p. 95-108.
4. Mitchell, R., *The role of microorganisms in the deterioration of atmospheric pollutants of stone used in historic buildings and monuments*. 1998-1999, NCPTT Grant number MT-2210-8-NC-23: Harvard University. p. 23.
5. Rodriguez-Navarro, C. and E. Doehne, *Salt weathering: influence of evaporation rate, supersaturation and crystallization pattern*. *Earth Surface Processes and Landforms*, 1999. **24**(3): p. 191-209.
6. Scherer, G.W., *Controlling Salt Damage*. 2009, NCPTT Grant No. MT-2210-09-NC-03: Princeton University. p. 20.
7. Hall, C. and W.D. Hoff, *Water Transport in Brick, Stone, and Concrete*. 2002, New York: Taylor & Francis.

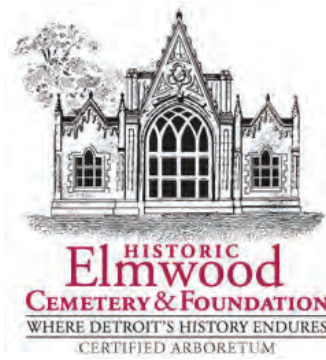

HISTORIC ELMWOOD CEMETERY & FOUNDATION
WHERE DETROIT'S HISTORY ENDURES



[Cemetery Services](#)

[Historic Elmwood Foundation](#)

[Events/News/Tours](#)

[Home](#) > [Cemetery Services](#) > Rules and Regulations

Rules and Regulations

ELMWOOD CEMETERY

(Revised February, 2007)

Purpose

The following rules and regulations have been adopted as a guide to the use and management of the Cemetery. The rules and regulations will help protect all who have interest here. All owners of interment rights, visitors and contractors performing work within the Cemetery shall be subjected to said rules and regulations, amendments or alterations as shall be adopted by the Trustees of Elmwood Cemetery from time to time.

Definitions

Crypt is a casket space in a mausoleum used for or intended to be used for the entombment of human remains.

Family Lot is an area of six lots or more restricted to a group of persons related by blood or marriage.

Lawn Crypt is an interment space in the Cemetery that contains a pre-constructed and pre-buried vault capable of holding a casket.

Lot is a grave, crypt or niche.

Memorial is a monument, tombstone, grave marker or headstone identifying a grave or graves or a nameplate with inscription identifying a crypt or niche.

Monument is an upright memorial made principally of stone.

Niche is a space in a mausoleum or columbarium used or intended to be used for the inurnment of cremated human remains.

Owner(s) is the person or persons to whom the Cemetery has conveyed a burial right or rights or a person or persons who have acquired such rights by transfer in accordance with the rules of the Cemetery or a person or persons who hold such burial right or rights by inheritance.

Single grave is a grave for one person.

Urn is a container used for cremated remains.

General Rules and Regulations

1. Rules and Regulations of the Cemetery and prices for burial spaces and services are made by the Cemetery and become effective upon approval by the Cemetery.

The Cemetery may, and it hereby expressly reserves the right, at any time, with or without notice to lot owners, to adopt new rules and regulations or to amend, alter and/or repeal any rule, regulation and/or article, section or paragraph in these Rules and Regulations. Special cases may arise in which the literal enforcement of the rule may impose unnecessary hardship. The Cemetery, therefore, reserves the right, without notice, to make exceptions, suspensions or modifications in any of the Rules and Regulations when, in its judgment, the same appear advisable, and such temporary exceptions, suspensions or modifications shall in no way be construed as affecting the general application of such.

2. The Cemetery retains to itself, for the benefit of all interment right owners, full and complete supervision, control and management of the land, buildings, improvements, roads, walks, utilities, development, books and records, and the full and complete authority, rights and privileges to make, change administer and enforce all rules and regulations and restrictions not inconsistent with the laws of this State wherein this Cemetery is located.

3. All lots in the Cemetery are sold in accordance with the provisions of the laws of the State of Michigan and shall not be used for any other purpose than as a burial place for dead human beings. All lots sold after 1949 are sold with permanent maintenance provision.

4. Lots must be paid in full before a burial is made. Full purchase price must be paid before a certificate of ownership is issued.

5. Visiting hours:

Cemetery Hours

Grounds

October 1 – April 30

8:30am – 4pm Daily

May 1 – September 30

7:00am – 7:00pm Daily

Office Hours

9:00am – 4pm Weekdays

9:00am – noon Saturdays
Closed Sunday

Any person found on the Cemetery grounds after closing will be considered a trespasser.

6. The Cemetery issues to each owner of the rights of burial for its lots, crypts or niches a Certificate of Ownership describing the location and naming the owner or owners of the said location. The naming of more than one owner is indicative of joint ownership in common with rights of survivorship.

The issuance of such certificate is the Cemetery's sole form of recognition of ownership. Possession of the Certificate by a person whom is not listed on the Certificate is not in itself evidence of ownership. Purchasers of lots, crypts or niches simply acquire the right of burial.

7. The owner of interment rights hereunder may dispose of same by will or, should the owner die in testate, such interment rights shall pass according to laws of this State governing intestacy provided, however, the Cemetery shall not be bound by such transfers unless and until an exemplification of record of same has been presented to it and such change has been recorded on the books and records of the Cemetery. Any plot, crypt or niche in which there are no burials, entombments or inurnments may be transferred to a new owner, providing the original Certificate of Ownership is submitted to the Cemetery together with proper transfer agreement, upon payment of transfer fee in accordance with the Cemetery's established schedule of charges.

8. In the event of loss or destruction of a Certificate of Ownership and upon the presentation of a written request, accompanied by a properly executed affidavit by the owner setting forth the circumstances of the loss or destruction and indemnification for the Cemetery, the Cemetery will prepare a duplicate Certificate from its records.

9. Lot owners are prohibited from allowing interments to be made on their lots for compensation.

10. If a lot owner sells or transfers title to his or her lot, as provided by these regulations, he or she must pay any and all indebtedness due the Cemetery before such transfer of title will be allowed.

11. All lot owners are required to notify the Cemetery of any change of address. All notices required to be sent shall be sent to the last recorded address and such notices shall be deemed adequate.

12. No person, other than employees of the Cemetery, shall be allowed to perform any work within the Cemetery without permission from the Cemetery.

13. The Cemetery shall direct all improvements within the grounds and upon all lots before and after interments have been made herein.

14. Charges for work and services performed by the Cemetery or for materials purchased from the Cemetery will be at rates as approved by the Cemetery.

15. The Cemetery will take all reasonable precautions to protect lot owners and their property within the Cemetery from loss, damage or injury but it shall not be responsible for any loss, damage or injury.

16. The use of the Cemetery land as a thoroughfare will not be permitted.

17. The right to use automobiles or other vehicles in the Cemetery is authorized solely and exclusively for the purpose of transporting persons to visit burial plots. The speed limit within the Cemetery is fifteen (15) miles per hour. Parking and/or driving on any gardens or grassy areas are prohibited for purposes other than those obtained from the Cemetery.

18. Bicycles, skates, snowmobiles, motorcycles, horses, etc., may not be used on Cemetery lands except with the approval of the Cemetery. Dogs are not permitted except when kept on a leash or in a vehicle.

19. Bringing alcoholic beverages or illegal drugs into the Cemetery is strictly prohibited.

20. The Cemetery shall have the right to enter upon or use any adjoining lot or lots to carry out its duties as to interments, erection of monuments or markers, etc., without prior notice to the lot owner.

21. No signs, notices or advertisements of any kind shall be allowed in the Cemetery unless placed by the Cemetery.

22. Peddling of any kind or soliciting the sale of any commodity, other than by the Cemetery, is prohibited within the confines of the Cemetery.

Interment & Funeral Regulations

23. Interments into a lot are restricted to those entitled to burial therein according to these rules and regulations.

24. The Cemetery shall be in no way liable for any delay in the interment of a body where a protest to the interment has been made or where the rules and regulations have not been complied with; and, further, the Cemetery reserves the right, under such circumstances, to place the body in the receiving vault until the full rights have been determined.

25. The use of one grave space shall be limited to interments as follows unless otherwise permitted by the Cemetery:

- a) One adult burial, or
- b) One adult burial and one infant burial, or
- c) One adult burial and three urns of cremated remains, or
- d) Four urns of cremated remains

The use and placement of memorials shall be governed by Rule 53 below.

26. No burial of a casket over three feet in length will be made unless there has been provided an outer container or receptacle of concrete or such other material which the Cemetery will deem to have comparable strength or resistance to deterioration.

27. Funerals are to be at the Cemetery by 3:00 p.m., Monday through Friday and by 2:00 p.m. on Saturday or be subject to overtime fees.

28. No disinterment will be allowed without permission of next of kin, the lot owner, the Cemetery and the proper authorities.

29. The Cemetery shall in no way be liable for any container, receptacle or urn of cremated remains placed in any lot, crypt or niche. A permanent type of urn or vault is required for ground interment of cremated remains. The scattering of cremated remains over a family lot is prohibited.

Flower & Decoration Regulations

30. The Cemetery reserves the right to remove all flowers, wreaths or other decorations from lots as soon as they become unsightly. The grounds will be cleared of decorations twice a year. Spring cleanup begins March 1, and Fall cleanup begins October 1. In order for a family to save any decorations placed on a grave, the decoration should be removed prior to these dates. New decorations may be placed beginning April 1 and November 1 respectively.

31. Fresh flower arrangements are allowed on lots in a disposable vase. Artificial flowers and glass containers are prohibited.

32. Grave blankets and wreaths are allowed as winter decorations from November 15 until the spring cleanup beginning March 1.

33. Items not allowed to be placed on a lot within the Cemetery include, but are not limited to, the following: shepherd's hooks, standup decorations, coping, curbing, decorative rocks, fencing, hedging, grave mounds, borders or enclosures. No decorations of any type are permitted in trees or Cemetery plantings.

34. Flags may be placed on graves on Memorial Day, the Fourth of July, Flag Day, and Veterans Day. Flags should be kept to 12" by 18" in size or smaller. Flags are subject to removal by Cemetery within ten (10) days of the Holiday.

35. Trees and shrubs are placed throughout the Cemetery by the Cemetery for overall beauty and serenity of the grounds. Individual graves are not permitted to have trees or shrubs. Any such tree or shrub not approved by the Cemetery may be removed without notice to the lot owner.

36. Certain lots embrace a tree that may interfere with space that otherwise might be used for burial. In such a case, the Cemetery recognizes that right to the retention of the trees as prior to the right of use of such space for burial. Should any such tree die naturally, the Cemetery will remove it at its own expense.

37. Glass is prohibited at all times.

38. Devotional lights of any type are prohibited in the Cemetery.

39. The Cemetery shall have the right to remove all objects whose appearance and condition warrant removal and/or violate the Cemetery's rules and regulations. The Cemetery also will not be liable for any flower or decoration removed or lost by any cause.

Planting Policies

Individual Burial Spaces

40. Planting will not be permitted to cover substantially an entire grave space or even the center or end of a grave away from the headstone.

41. Planting will be permitted in the area the length and width of a headstone and directly below the same.

42. Artificial flowers, displays and designs will not be permitted anywhere except artificial wreaths simulating dark green or dark brown leaves with modest use of contrasting berries will be permitted if maintained in slightly condition and in proper position.

43. Winter blankets and sprays made of artificial flowers and material will not be permitted. They must be of balsam or pine and decorations confined to red ruscus, natural or silvered pinecones and red berries. Removal tags must be attached or purchased at the Cemetery office.

Family Burial Lots

44. The foregoing regulations relative to plants on single grave spaces will apply also to family burial lots except that family lot proprietors may obtain approval from the General Manager or his or her designee (to be given only in writing) of other forms of planting if considered consistent with the general landscaping of the particular part of the Cemetery and if adequate arrangements are made for the care of the planting and for any added cost of maintaining surrounding grass areas.

Family Monuments

45. Monuments are not permitted except on a lot (consisting of six or more single grave spaces) and except in accordance with these rules. Where the configuration of the lot permits a family monument, the size, material and design of the monument must be submitted for prior approval by the Trustees of Elmwood Cemetery. No monument on any lot, other than those so designated in the prior rules, shall be installed without first being reviewed and approved by the Trustees.

Markers and Monuments

46. All memorials must be made of the highest quality standard bronze or of granite approved by the Cemetery except on the monument lots where all monuments shall be made of granite. All markers on individual graves shall be set flush except in limited designated area. The granites which will be accepted at Elmwood are limited to quality granites and in colors approved by the Cemetery. The following granites and colors have been pre-approved as of the date hereof: Barre Gray, Ebony Mist Black, Mahogany, Missouri Red, Dominion Pink, Mountain Rose Pink, Blue Pearl and Waussau.

47. The Cemetery shall have the authority to reject any memorial that, on account of its size, type, design, inscription, quality, color or method of construction is unsuitable for the particular lot or grave on which it is to be placed. The Cemetery reserves the right to prevent the placing or to remove any marker or other objects that do not comply with the standards of the Cemetery. Also, the Cemetery reserves the right to require the purchase of any and all markers from the Cemetery or approved producers or retail dealers.

48. No marker or monument will be accepted by the Cemetery for installation unless a sketch has been furnished defining the dimensions, material content and lettering and permission of the lot owner or proper agent of the person having burial rights in the grave to be marked. All markers and monument foundations shall be placed by employees or agents of the Cemetery only.

49. All fees or encumbrances due on a lot must be paid in full prior to any memorial being placed on the lot, including any installation fee.

50. Corner markers are allowed on all lots and must be installed at grade level.

51. In the event a memorial is placed where it is necessary to remove it for an interment or disinterment, the Cemetery shall have the right to remove such memorial without notice to the lot owner.

52. The Cemetery may, at its own expense, without any liability, correct any error that may occur in the placing of a foundation or memorial.

53. Memorials shall be set in accordance with the general plan of the Cemetery. Not more than two (2) memorials may be placed on a grave, one at the head and the other at the foot, unless otherwise approved by the Cemetery.

54. No photographs or porcelain material may be incorporated into any memorial. No protective glass or breakable material of any kind will be allowed on the memorial.

55. Monuments cannot exceed one-half of the width of the lot or a six-foot maximum. The tablet must be at least eight inches thick. The base and tablet together cannot exceed five feet in height except on lots specifically plotted for larger family monuments or family mausoleums.

56. Marker Regulations: Sections 7, 6, 2; On lots as designated on maps of the Cemetery, respectively, will permit slant style markers made of Gray granite to all be 24 inches by 10 inches in length and 16 inches high. All the slant style memorials will have rock pitch sides, back and top. This is the only style, size and material permitted on these lots.

57. Monument Regulations: Sections R and T; On lots as designated on maps of the Cemetery. Upright family monuments or lawn level memorials are permitted on these lots. The upright family monuments must be made of quality granite and in colors approved by the Cemetery. The following granites and colors have been pre-approved as of the date hereof: Barre Gray, Ebony Mist Black, Mahogany, Missouri Red, Dominion Pink, Mountain Rose Pink, Blue Pearl and Waussau. The monument base must be rock pitched on all four sides with a polished or steeled top. The tablet, or die, must have a polished or steeled front, back and top. The sides must be rock pitched. The monuments may only be one of the following two sizes:

Tablet 30 inches by 8 inches by 20 inches high

Base 40 inches by 14 inches by 8 inches high

Tablet 36 inches by 8 inches by 24 inches high

Base 46 inches by 14 inches by 8 inches high

Mausoleum

58. All entombments or inurnments in the mausoleum must be performed by regular employees of the Cemetery. All bodies to be entombed in the mausoleum must be embalmed.

59. Such entombments must be made in a casket understanding the crypt dimensions are 2' 8" wide by 2' 2" high by 7' 8" deep.

60. The Cemetery will provide all inscriptions, lettering or crypt plates on the crypt or niche fronts to ensure uniformity. Either a floral tribute area or vase will be provided for each crypt.
61. The Cemetery reserves the right to limit floral tributes. Only one floral tribute per crypt or niche is allowed to be placed on the benches or other holders where provided.
62. The Cemetery reserves the right to remove all flowers, wreaths or other decorations from the mausoleum as soon as they become unsightly. The mausoleum will be cleared of decorations once a year. The annual cleanup will begin March 1. In order for a family to save any decorations placed in the mausoleum, the decorations should be removed prior to these dates. New decorations may be placed beginning April 1.
63. Visiting hours are as posted in the Cemetery. Any person found in the mausoleum after closing without permission will be considered a trespasser.
64. No decorative objects or photos may be affixed to the crypt fronts by tape or other means. No toys, glass containers, ceramic containers or like objects shall be permitted in the mausoleum. All such unauthorized items will be removed by the Cemetery without notice.
65. All niche spaces in the mausoleum are intended for an individual inurnment. A container of suitable material is required.

©2019 Historic Elmwood Cemetery & Foundation • 1200 Elmwood Avenue • Detroit, Michigan 48207 • Phone: 313-567-3453 • Fax: 313-567-8861

Cemetery Services

About Us
 Preplanning
 Services
 Traditional Burial
 Mausoleum Entombment
 Cremation
 Schedule of Charges
 Markers and Memorials
 Markers and Monument Memorial Cleaning
 Floral and Holiday Tributes
 Genealogy Inquiries
 Cemetery Map
 Contact Us
 Rules and Regulations
 Elmwood Family of Cemeteries
 Greenwood Historic Cemetery
 Glenwood Cemetery
 Lafayette Cemetery of Temple Beth El

Historic Elmwood Foundation

Mission
 History of Elmwood Cemetery
 History of Elmwood Foundation
 Community Events
 Donate Today!
 Donors
 Bequests
 Elmwood Grants

Events/News/Tours

Events
 Newsletters
 Photo Gallery
 Biographies
 African-American Heritage Audio Tour
 Leadership Legacies Audio Tour
 Business Visionaries Audio Tour
 Sign Up For Our e-Newsletter

[Home](#) > [How to Preserve](#) > [Preservation Briefs](#) > 2 Repointing Mortar Joints

Some of the web versions of the Preservation Briefs differ somewhat from the printed versions. Many illustrations are new and in color; Captions are simplified and some complex charts are omitted. To order hard copies of the Briefs, see [Printed Publications](#).

PRESERVATION BRIEFS

2



Soft mortar for repointing. Photo: John P. Speweik.

Repointing Mortar Joints in Historic Masonry Buildings

Robert C. Mack, FAIA, and John P. Speweik

- Historical Background
- Identifying the Problem Before Repointing
- Finding an Appropriate Mortar Match
- Properties of Mortar
- Mortar Analysis
- Components of Mortar
- Mortar Type and Mix
- Budgeting and Scheduling
- Contractor Selection
- Execution of the Work
- Visually Examining the Mortar and the Masonry Units
- Summary and References
- Reading List
- Download the PDF

Masonry—brick, stone, terra-cotta, and concrete block—is found on nearly every historic building. Structures with all-masonry exteriors come to mind immediately, but most other buildings at least have masonry foundations or chimneys. Although generally considered "permanent," masonry is subject to deterioration, especially at the mortar joints. Repointing, also known simply as "pointing" or—somewhat inaccurately—"tuck pointing"* , is the process of removing deteriorated mortar from the joints of a masonry wall and replacing it with new mortar. Properly done, repointing restores the visual and physical integrity of the masonry. Improperly done, repointing not only detracts from the appearance of the building, but may also cause physical damage to the masonry units themselves.

The purpose of this Brief is to provide general guidance on appropriate materials and methods for repointing historic masonry buildings and it is intended to benefit building owners, architects, and contractors. The Brief should serve as a guide to prepare specifications for repointing historic masonry buildings. It should also help develop sensitivity to the particular needs of historic masonry, and to assist historic building owners in working cooperatively with architects, architectural conservators and historic preservation consultants, and contractors. Although specifically intended for historic buildings, the guidance is appropriate for other masonry buildings as well. This publication updates *Preservation Briefs 2: Repointing Mortar Joints in Historic Brick Buildings* to include all types of historic unit masonry. The scope of the earlier Brief has also been expanded to acknowledge that the many buildings constructed in the first half of the 20th century are now historic and eligible for listing in the National Register of Historic Places, and that they may have been originally constructed with portland cement mortar.

** Tuckpointing technically describes a primarily decorative application of a raised mortar joint or lime putty joint on top of flush mortar joints.*

Historical Background [return to top ▲](#)

Mortar consisting primarily of lime and sand has been used as an integral part of masonry structures for thousands of years. Up until about the mid-19th century, lime or quicklime (sometimes called lump lime) was delivered to construction sites, where it had to be slaked, or combined with water. Mixing with water caused it to boil and resulted in a wet lime putty that was left to mature in a pit or wooden box for several weeks, up to a year. Traditional mortar was made from lime putty, or slaked lime, combined with local sand, generally in a ratio of 1 part lime putty to 3 parts sand by volume. Often other ingredients, such as crushed marine shells (another source of lime), brick dust, clay, natural cements, pigments, and even animal hair were also added to mortar, but the basic formulation for lime putty and sand mortar remained unchanged for centuries until the advent of portland cement or its forerunner, Roman cement, a natural, hydraulic cement.

Portland cement was patented in Great Britain in 1824. It was named after the stone from Portland in Dorset which it resembled when hard. This is a fast-curing, hydraulic cement which hardens under water. Portland cement was first manufactured in the United States in 1871, although it was imported before this date. But it was not in common use throughout the country until the early 20th century. Up until the turn of the century portland cement was considered primarily an additive, or "minor ingredient" to help accelerate mortar set time. By the 1930s, however, most masons used a mix of equal parts portland cement and lime putty. Thus, the mortar found in masonry structures built between 1871 and 1930 can range from pure lime and sand mixes to a wide variety of lime, portland cement, and sand combinations.

In the 1930s more new mortar products intended to hasten and simplify masons' work were introduced in the U.S. These included **masonry cement**, a premixed, bagged mortar which is a combination of portland cement and ground limestone, and **hydrated lime**, machine-slaked lime that eliminated the necessity of slaking quicklime into putty at the site.

Identifying the Problem Before Repointing [return to top ▲](#)

The decision to repoint is most often related to some obvious sign of deterioration, such as disintegrating mortar, cracks in mortar joints, loose bricks or stones, damp walls, or damaged plasterwork. It is, however, erroneous to assume that repointing alone will solve deficiencies that result from other problems. The root cause of the deterioration—leaking roofs or gutters, differential settlement of the building, capillary action causing rising damp, or extreme weather exposure—should always be dealt with prior to beginning work.



Masons practice using lime putty mortar to repair historic marble. Photo: NPS files.

Without appropriate repairs to eliminate the source of the problem, mortar deterioration will continue and any repointing will have been a waste of time and money.

Use of Consultants

Because there are so many possible causes for deterioration in historic buildings, it may be desirable to retain a consultant, such as a historic architect or architectural conservator, to analyze the building. In addition to determining the most appropriate solutions to the problems, a consultant can prepare specifications which reflect the particular requirements of each job and can provide oversight of the work in progress. Referrals to preservation consultants frequently can be obtained from State Historic Preservation Offices, the American Institute for Conservation of Historic and Artistic Works (AIC), the Association for Preservation Technology (APT), and local chapters of the American Institute of Architects (AIA).

Finding an Appropriate Mortar Match [return to top ▲](#)

Preliminary research is necessary to ensure that the proposed repointing work is both physically and visually appropriate to the building. Analysis of unweathered portions of the historic mortar to which the new mortar will be matched can suggest appropriate mixes for the repointing mortar so that it will not damage the building because it is excessively strong or vapor impermeable.

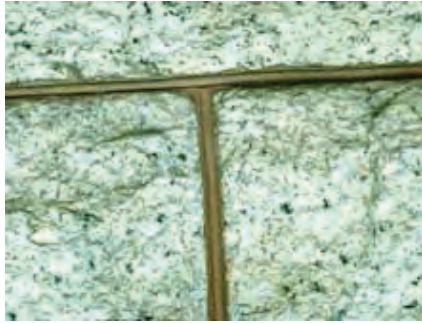

This late 19th century granite has recently been repointed with the joint profile and mortar color carefully matched to the original. Photo: NPS files.

Examination and analysis of the masonry units—brick, stone or terra cotta—and the techniques used in the original construction will assist in maintaining the building's historic appearance. A simple, non- technical, evaluation of the masonry units and mortar can provide information concerning the relative strength and permeability of each—critical factors in selecting the repointing mortar—while a visual analysis of the historic mortar can provide the information necessary for developing the new mortar mix and application techniques.

Although not crucial to a successful repointing project, for projects involving properties of special historic significance, a mortar analysis by a qualified laboratory can be useful by providing information on the original ingredients. However, there are limitations with such an analysis, and replacement mortar specifications should not be based solely on laboratory analysis. Analysis requires interpretation, and there are important factors which affect the condition and performance of the mortar that cannot be established through laboratory analysis. These may include: the original water content, rate of curing, weather conditions during original construction, the method of mixing and placing the mortar, and the cleanliness and condition of the sand. *The most useful information that can come out of laboratory analysis is the identification of sand by gradation and color.* This allows the color and the texture of the mortar to be matched with some accuracy because sand is the largest ingredient by volume.

In creating a repointing mortar that is compatible with the masonry units, the objective is to achieve one that matches the historic mortar as closely as possible, so that the new material can coexist with the old in a sympathetic, supportive and, if necessary, sacrificial capacity. The exact physical and chemical properties of the historic mortar are not of major significance as long as the new mortar conforms to the following criteria:

- The new mortar must match the historic mortar in **color, texture and tooling**. (If a laboratory analysis is undertaken, it may be possible to match the binder components and their proportions with the historic mortar, if those materials are available.)

- The **sand must match the sand** in the historic mortar. (The color and texture of the new mortar will usually fall into place if the sand is matched successfully.)
- The new mortar must have **greater vapor permeability** and be **softer** (measured in compressive strength) than the masonry units.
- The new mortar must be **as vapor permeable** and **as soft or softer** (measured in compressive strength) than the historic mortar. (Softness or hardness is not necessarily an indication of permeability; old, hard lime mortars can still retain high permeability.)



This mortar is the proper consistency for repointing historic brick. Photo: John P. Speweik.

Mortar Analysis [return to top ▲](#)

Methods for analyzing mortars can be divided into two broad categories: **wet chemical** and **instrumental**. Many laboratories that analyze historic mortars use a simple **wet-chemical** method called acid digestion, whereby a sample of the mortar is crushed and then mixed with a dilute acid. The acid dissolves all the carbonate-containing minerals not only in the binder, but also in the aggregate (such as oyster shells, coral sands, or other carbonate-based materials), as well as any other acid-soluble materials. The sand and fine-grained acid-insoluble material is left behind. There are several variations on the simple acid digestion test. One involves collecting the carbon dioxide gas given off as the carbonate is digested by the acid; based on the gas volume the carbonate content of the mortar can be accurately determined (Jedrzejska, 1960). Simple acid digestion methods are rapid, inexpensive, and easy to perform, but the information they provide about the original composition of a mortar is limited to the color and texture of the sand. The gas collection method provides more information about the binder than a simple acid digestion test.

Instrumental analysis methods that have been used to evaluate mortars include polarized light or thin-section microscopy, scanning electron microscopy, atomic absorption spectroscopy, X-ray

diffraction, and differential thermal analysis. All instrumental methods require not only expensive, specialized equipment, but also highly-trained experienced analysts. However, instrumental methods can provide much more information about a mortar. Thin-section microscopy is probably the most commonly used instrumental method. Examination of thin slices of a mortar in transmitted light is often used to supplement acid digestion methods, particularly to look for carbonate-based aggregate. For example, the new ASTM test method, ASTM C 1324-96 "Test Method for Examination and Analysis of Hardened Mortars" which was designed specifically for the analysis of modern lime-cement and masonry cement mortars, combines a complex series of wet chemical analyses with thin-section microscopy.

The drawback of most mortar analysis methods is that mortar samples of known composition have not been analyzed in order to evaluate the method. Historic mortars were not prepared to narrowly defined specifications from materials of uniform quality; they contain a wide array of locally derived materials combined at the discretion of the mason. While a particular method might be able to accurately determine the original proportions of a lime-cement-sand mortar prepared from modern materials, the usefulness of that method for evaluating historic mortars is questionable unless it has been tested against mortars prepared from materials more commonly used in the past.

Properties of Mortar [return to top ▲](#)

Mortars for repointing should be softer or more permeable than the masonry units and no harder or more impermeable than the historic mortar to prevent damage to the masonry units. It is a common error to assume that hardness or high strength is a measure of appropriateness, particularly for lime-based historic mortars. Stresses within a wall caused by expansion, contraction, moisture migration, or settlement must be accommodated in some manner; in a masonry wall, these stresses should be relieved by the mortar rather than by the masonry units. A mortar that is stronger in compressive strength than the masonry units will not "give," thus causing stresses to be relieved through the masonry units—resulting in permanent damage to the masonry, such as cracking and spalling, that cannot be repaired easily.



This early 19th century building is being repointed with lime mortar. Photo: Travis McDonald.

While stresses can also break the bond between the mortar and the masonry units, permitting water to penetrate the resulting hairline cracks, this is easier to correct in the joint through repointing than if the break occurs in the masonry units.

Permeability, or rate of vapor transmission, is also critical. High lime mortars are more permeable than denser cement mortars. Historically, mortar acted as a bedding material—not unlike an expansion joint—rather than a "glue" for the masonry units, and moisture was able to migrate through the mortar joints rather than the masonry units. When moisture evaporates from the masonry it deposits any soluble salts either on the surface as *efflorescence* or below the surface as *subflorescence*. While salts deposited on the surface of masonry units are usually relatively harmless, salt crystallization within a masonry unit creates pressure that can cause parts of the outer surface to spall off or delaminate. If the mortar does not permit moisture or moisture vapor to migrate out of the wall and evaporate, the result will be damage to the masonry units.

Components of Mortar [return to top ▲](#)

Sand

Sand is the largest component of mortar and the material that gives mortar its distinctive color, texture and cohesiveness. Sand must be free of impurities, such as salts or clay. The three key characteristics of sand are: particle shape, gradation and void ratios.

When viewed under a magnifying glass or low-power microscope, particles of sand generally have either rounded edges, such as found in beach and river sand, or sharp, angular edges, found in crushed or manufactured sand. For repointing mortar, rounded or natural sand is

preferred for two reasons. It is usually similar to the sand in the historic mortar and provides a better visual match. It also has better working qualities or plasticity and can thus be forced into the joint more easily, forming a good contact with the remaining historic mortar and the surface of the adjacent masonry units. Although manufactured sand is frequently more readily available, it is usually possible to locate a supply of rounded sand.

The gradation of the sand (particle size distribution) plays a very important role in the durability and cohesive properties of a mortar. Mortar must have a certain percentage of large to small particle sizes in order to deliver the optimum performance. Acceptable guidelines on particle size distribution may be found in ASTM C 144 (American Society for Testing and Materials). However, in actuality, since neither historic nor modern sands are always in compliance with ASTM C 144, matching the same particle appearance and gradation usually requires sieving the sand.

A scoop of sand contains many small voids between the individual grains. A mortar that performs well fills all these small voids with binder (cement/lime combination or mix) in a balanced manner. Well-graded sand generally has a 30 per cent void ratio by volume. Thus, 30 per cent binder by volume generally should be used, unless the historic mortar had a different binder: aggregate ratio. This represents the 1:3 binder to sand ratios often seen in mortar specifications.

For repointing, sand generally should conform to ASTM C 144 to assure proper gradation and freedom from impurities; some variation may be necessary to match the original size and gradation. Sand color and texture also should match the original as closely as possible to provide the proper color match without other additives.

Lime

Mortar formulations prior to the late-19th century used lime as the primary binding material. Lime is derived from heating limestone at high temperatures which burns off the carbon dioxide, and turns the limestone into quicklime. There are three types of limestone—calcium, magnesium, and dolomitic—differentiated by the different levels of magnesium carbonate they contain which impart specific qualities to mortar. Historically, calcium lime was used for mortar rather than the dolomitic lime (calcium magnesium carbonate) most often used today. But it is also important to keep in mind the fact that the historic limes, and other components of mortar, varied a great deal because they were natural, as opposed to modern lime which is manufactured and, therefore, standardized. Because some of the kinds of lime, as well as other components of mortar, that were used historically are no longer readily available, even when a conscious effort is made to replicate a "historic" mix, this may not be achievable due to the differences between modern and historic materials.



Caulking was inappropriately used here in place of mortar on the top of the wall. As a result, it has not been durable. Photo: NPS files.

Lime, itself, when mixed with water into a paste is very plastic and creamy. It will remain workable and soft indefinitely, if stored in a sealed container. Lime (calcium hydroxide) hardens by carbonation absorbing carbon dioxide primarily from the air, converting itself to calcium carbonate. Once a lime and sand mortar is mixed and placed in a wall, it begins the process of carbonation. If lime mortar is left to dry too rapidly, carbonation of the mortar will be reduced, resulting in poor adhesion and poor durability. In addition, lime mortar is slightly water soluble and thus is able to re-seal any hairline cracks that may develop during the life of the mortar. Lime mortar is soft, porous, and changes little in volume during temperature fluctuations thus making it a good choice for historic buildings. *Because of these qualities, high calcium lime mortar may be considered for many repointing projects, not just those involving historic buildings.*

For repointing, lime should conform to ASTM C 207, Type S, or Type SA, Hydrated Lime for Masonry Purposes. This machine-slaked lime is designed to assure high plasticity and water retention. The use of quicklime which must be slaked and soaked by hand may have advantages over hydrated lime in some restoration projects if time and money allow.

Lime Putty

Lime putty is slaked lime that has a putty or paste-like consistency. It should conform to ASTM C 5. Mortar can be mixed using lime putty according to ASTM C 270 property or proportion specification.

Portland Cement

More recent, 20th-century mortar has used portland cement as a primary binding material. A straight portland cement and sand mortar is extremely hard, resists the movement of water, shrinks upon setting, and undergoes relatively large thermal movements. When mixed with

water, portland cement forms a harsh, stiff paste that is quite unworkable, becoming hard very quickly. (Unlike lime, portland cement will harden regardless of weather conditions and does not require wetting and drying cycles.) Some portland cement assists the workability and plasticity of the mortar without adversely affecting the finished project; it also provides early strength to the mortar and speeds setting. Thus, it may be appropriate to add some portland cement to an essentially lime-based mortar even when repointing relatively soft 18th or 19th century brick under some circumstances when a slightly harder mortar is required. The more portland cement that is added to a mortar formulation the harder it becomes—and the faster the initial set.

For repointing, portland cement should conform to ASTM C 150. White, non-staining portland cement may provide a better color match for some historic mortars than the more commonly available grey portland cement. But, it should not be assumed, however, that white portland cement is always appropriate for all historic buildings, since the original mortar may have been mixed with grey cement. The cement should not have more than 0.60 per cent alkali to help avoid efflorescence.

Masonry Cement

Masonry cement is a preblended mortar mix commonly found at hardware and home repair stores. It is designed to produce mortars with a compressive strength of 750 psi or higher when mixed with sand and water at the job site. It may contain hydrated lime, but it always contains a large amount of portland cement, as well as ground limestone and other workability agents, including air-entraining agents. Because masonry cements are not required to contain hydrated lime, and generally do not contain lime, they produce high strength mortars that can damage historic masonry. *For this reason, they generally are not recommended for use on historic masonry buildings.*

Lime Mortar (pre-blended)

Hydrated lime mortars, and pre-blended lime putty mortars with or without a matched sand are commercially available. Custom mortars are also available with color. In most instances, pre-blended lime mortars containing sand may not provide an exact match; however, if the project calls for total repointing, a pre-blended lime mortar may be worth considering as long as the mortar is compatible in strength with the masonry. If the project involves only selected, "spot" repointing, then it may be better to carry out a mortar analysis which can provide a custom pre-blended lime mortar with a matching sand. In either case, if a preblended lime mortar is to be used, it should contain Type S or SA hydrated lime conforming to ASTM C 207.

Water

Water should be potable—clean and free from acids, alkalis, or other dissolved organic materials.

Other Components

Historic components

In addition to the color of the sand, the texture of the mortar is of critical importance in duplicating historic mortar. Most mortars dating from the mid-19th century on—with some exceptions—have a fairly homogeneous texture and color. Some earlier mortars are not as uniformly textured and may contain lumps of partially burned lime or "dirty lime", shell (which often provided a source of lime, particularly in coastal areas), natural cements, pieces of clay, lampblack or other pigments, or even animal hair. The visual characteristics of these mortars can be duplicated through the use of similar materials in the repointing mortar.

Replicating such unique or individual mortars will require writing new specifications for each project. If possible, suggested sources for special materials should be included. For example, crushed oyster shells can be obtained in a variety of sizes from poultry supply dealers.

Pigments

Some historic mortars, particularly in the late 19th century, were tinted to match or contrast with the brick or stone. Red pigments, sometimes in the form of brick dust, as well as brown, and black pigments were commonly used. Modern pigments are available which can be added to the mortar at the job site, but they should not exceed 10 per cent by weight of the portland cement in the mix, and carbon black should be limited to 2 per cent. Only synthetic mineral oxides, which are alkali-proof and sun-fast, should be used to prevent bleaching and fading.

Modern Components

Admixtures are used to create specific characteristics in mortar, and whether they should be used will depend upon the individual project. *Air entraining agents*, for example, help the mortar to resist freeze-thaw damage in northern climates. *Accelerators* are used to reduce mortar freezing prior to setting while *retarders* help to extend the mortar life in hot climates. Selection of admixtures should be made by the architect or architectural conservator as part of the specifications, not something routinely added by the masons.

Generally, modern chemical additives are unnecessary and may, in fact, have detrimental effects in historic masonry projects. The use of antifreeze compounds is not recommended. They are not very effective with high lime mortars and may introduce salts, which may cause efflorescence later. A better practice is to warm the sand and water, and to protect the completed work from freezing. No definitive study has determined whether air-entraining additives should be used to resist frost action and enhance plasticity, but in areas of extreme exposure requiring high-strength mortars with lower permeability, air-entrainment of 10-16 percent may be desirable

(see formula for "severe weather exposure" in Mortar Type and Mix). Bonding agents are not a substitute for proper joint preparation, and they should generally be avoided. If the joint is properly prepared, there will be a good bond between the new mortar and the adjacent surfaces. In addition, a bonding agent is difficult to remove if smeared on a masonry surface.

Mortar Type and Mix [return to top ▲](#)

Mortars for repointing projects, especially those involving historic buildings, typically are custom mixed in order to ensure the proper physical and visual qualities. These materials can be combined in varying proportions to create a mortar with the desired performance and durability. The actual specification of a particular mortar type should take into consideration all of the factors affecting the life of the building including: current site conditions, present condition of the masonry, function of the new mortar, degree of weather exposure, and skill of the mason.



Here, a hammer and chisel are being correctly used to prepare a joint for repointing. Photo: John P. Speweik.

Thus, no two repointing projects are exactly the same. Modern materials specified for use in repointing mortar should conform to specifications of the American Society for Testing and Materials (ASTM) or comparable federal specifications, and the resulting mortar should conform to ASTM C 270, Mortar for Unit Masonry.

Specifying the proportions for the repointing mortar for a specific job is not as difficult as it might seem. Five mortar types, each with a corresponding recommended mix, have been established by ASTM to distinguish high strength mortar from soft flexible mortars. The ASTM designated them in decreasing order of approximate general strength as Type M (2,500 psi), Type S (1,800 psi), Type N (750 psi), Type O (350 psi) and Type K (75 psi). (The letters identifying the types are from the words MASON WORK using every other letter.) Type K has the highest lime content of the mixes that contain portland cement, although it is seldom used today, except for some historic preservation projects. The designation "L" in the accompanying chart identifies a straight

lime and sand mix. Specifying the appropriate ASTM mortar by proportion of ingredients, will ensure the desired physical properties. Unless specified otherwise, measurements or proportions for mortar mixes are always given in the following order: cement-lime-sand. Thus, a Type K mix, for example, would be referred to as 1-3-10, or 1 part cement to 3 parts lime to 10 parts sand. Other requirements to create the desired visual qualities should be included in the specifications.

The strength of a mortar can vary. If mixed with higher amounts of portland cement, a harder mortar is obtained. The more lime that is added, the softer and more plastic the mortar becomes, increasing its workability. A mortar strong in compressive strength might be desirable for a hard stone (such as granite) pier holding up a bridge deck, whereas a softer, more permeable lime mortar would be preferable for a historic wall of soft brick. Masonry deterioration caused by salt deposition results when the mortar is less permeable than the masonry unit. A strong mortar is still more permeable than hard, dense stone. However, in a wall constructed of soft bricks where the masonry unit itself has a relatively high permeability or vapor transmission rate, a soft, high lime mortar is necessary to retain sufficient permeability.

Budgeting and Scheduling [return to top ▲](#)

Repointing is both expensive and time consuming due to the extent of handwork and special materials required. It is preferable to repoint only those areas that require work rather than an entire wall, as is often specified. But, if 25 to 50 per cent or more of a wall needs to be repointed, repointing the entire wall may be more cost effective than spot repointing.



When repairing this stone wall, the mason matched the raised profile of the original tuckpointing. Photo: NPS files.

Total repointing may also be more sensible when access is difficult, requiring the erection of expensive scaffolding (unless the majority of the mortar is sound and unlikely to require replacement in the foreseeable future). Each project requires judgement based on a variety of factors. Recognizing this at the outset will help to prevent many jobs from becoming prohibitively expensive.

In scheduling, seasonal aspects need to be considered first. Generally speaking, wall temperatures between 40 and 95 degrees F (8 and 38 degrees C) will prevent freezing or excessive evaporation of the water in the mortar. Ideally, repointing should be done in shade, away from strong sunlight in order to slow the drying process, especially during hot weather. If necessary, shade can be provided for large-scale projects with appropriate modifications to scaffolding.

The relationship of repointing to other work proposed on the building must also be recognized. For example, if paint removal or cleaning is anticipated, and if the mortar joints are basically sound and need only selective repointing, it is generally better to postpone repointing until after completion of these activities. However, if the mortar has eroded badly, allowing moisture to penetrate deeply into the wall, repointing should be accomplished before cleaning. Related work, such as structural or roof repairs, should be scheduled so that they do not interfere with repointing and so that all work can take maximum advantage of erected scaffolding.



A mechanical grinder improperly used to cut out the horizontal joint and incompatible repointing have seriously damaged the 19th century brick. Photo: NPS files.

Building managers also must recognize the difficulties that a repointing project can create. The process is time consuming, and scaffolding may need to remain in place for an extended period of time. The joint preparation process can be quite noisy and can generate large quantities of dust which must be controlled, especially at air intakes to protect human health, and also where it might damage operating machinery. Entrances may be blocked from time to time making access difficult for both building tenants and visitors. Clearly, building managers will need to coordinate the repointing work with other events at the site.

Contractor Selection [return to top ▲](#)

Contractor Selection The ideal way to select a contractor is to ask knowledgeable owners of recently repointed historic buildings for recommendations. Qualified contractors then can provide

lists of other repointing projects for inspection. More commonly, however, the contractor for a repointing project is selected through a competitive bidding process over which the client or consultant has only limited control. In this situation it is important to ensure that the specifications stipulate that masons must have a minimum of five years' experience with repointing historic masonry buildings to be eligible to bid on the project. Contracts are awarded to the lowest responsible bidder, and bidders who have performed poorly on other projects usually can be eliminated from consideration on this basis, even if they have the lowest prices.

The contract documents should call for unit prices as well as a base bid. Unit pricing forces the contractor to determine in advance what the cost addition or reduction will be for work which varies from the scope of the base bid. If, for example, the contractor has fifty linear feet less of stone repointing than indicated on the contract documents but thirty linear feet more of brick repointing, it will be easy to determine the final price for the work. Note that each type of work—brick repointing, stone repointing, or similar items—will have its own unit price. The unit price also should reflect quantities; one linear foot of pointing in five different spots will be more expensive than five contiguous linear feet.

Execution of the Work [return to top ▲](#)

Test Panels

These panels are prepared by the contractor using the same techniques that will be used on the remainder of the project. Several panel locations—preferably not on the front or other highly visible location of the building—may be necessary to include all types of masonry, joint styles, mortar colors, and other problems likely to be encountered on the job.



Unskilled repointing has negatively impacted the character of this late-19th century building.
Photo: NPS files.

If cleaning tests, for example, are also to be undertaken, they should be carried out in the same location. Usually a 3 foot by 3 foot area is sufficient for brickwork, while a somewhat larger area may be required for stonework. These panels establish an acceptable standard of work and serve as a benchmark for evaluating and accepting subsequent work on the building.

Joint Preparation

Old mortar should be removed to a minimum depth of 2 to 2-1/2 times the width of the joint to ensure an adequate bond and to prevent mortar "popouts." For most brick joints, this will require removal of the mortar to a depth of approximately Ω to 1 inch; for stone masonry with wide joints, mortar may need to be removed to a depth of several inches. Any loose or disintegrated mortar beyond this minimum depth also should be removed.

Although some damage may be inevitable, careful joint preparation can help limit damage to masonry units. The traditional manner of removing old mortar is through the use of hand chisels and mash hammers. Though labor-intensive, in most instances this method poses the least threat for damage to historic masonry units and produces the best final product.

The most common method of removing mortar, however, is through the use of power saws or grinders. The use of power tools by unskilled masons can be disastrous for historic masonry, particularly soft brick. Using power saws on walls with thin joints, such as most brick walls, almost always will result in damage to the masonry units by breaking the edges and by overcutting on the head, or vertical joints.

However, small pneumatically-powered chisels generally can be used safely and effectively to remove mortar on historic buildings as long as the masons maintain appropriate control over the equipment. Under certain circumstances, thin diamond-bladed grinders may be used to cut out *horizontal* joints only on hard portland cement mortar common to most early-20th century masonry buildings. Usually, automatic tools most successfully remove old mortar without damaging the masonry units when they are used in combination with hand tools in preparation for repointing. Where horizontal joints are uniform and fairly wide, it may be possible to use a power masonry saw to assist the removal of mortar, such as by cutting along the middle of the joint; final mortar removal from the sides of the joints still should be done with a hand chisel and hammer. Caulking cutters with diamond blades can sometimes be used successfully to cut out joints without damaging the masonry. Caulking cutters are slow; they do not rotate, but vibrate at very high speeds, thus minimizing the possibility of damage to masonry units. Although mechanical tools may be safely used in limited circumstances to cut out horizontal joints in preparation for repointing, they should never be used on vertical joints because of the danger of slipping and cutting into the brick above or below the vertical joint. Using power tools to remove mortar without damaging the surrounding masonry units also necessitates highly skilled masons

experienced in working on historic masonry buildings. Contractors should demonstrate proficiency with power tools before their use is approved.

Using any of these power tools may also be more acceptable on hard stone, such as quartzite or granite, than on terra cotta with its glass-like glaze, or on soft brick or stone. The test panel should determine the acceptability of power tools. If power tools are to be permitted, the contractor should establish a quality control program to account for worker fatigue and similar variables.

Mortar should be removed cleanly from the masonry units, leaving square corners at the back of the cut. Before filling, the joints should be rinsed with a jet of water to remove all loose particles and dust. At the time of filling, the joints should be damp, but with no standing water present. For masonry walls—limestone, sandstone and common brick—that are extremely absorbent, it is recommended that a continual mist of water be applied for a few hours before repointing begins.

Mortar Preparation

Mortar components should be measured and mixed carefully to assure the uniformity of visual and physical characteristics. Dry ingredients are measured by volume and thoroughly mixed before the addition of any water. Sand must be added in a damp, loose condition to avoid over sanding. Repointing mortar is typically pre-hydrated by adding water so it will just hold together, thus allowing it to stand for a period of time before the final water is added. Half the water should be added, followed by mixing for approximately 5 minutes. The remaining water should then be added in small portions until a mortar of the desired consistency is reached. The total volume of water necessary may vary from batch to batch, depending on weather conditions. It is important to keep the water to a minimum for two reasons: first, a drier mortar is cleaner to work with, and it can be compacted tightly into the joints; second, with no excess water to evaporate, the mortar cures without shrinkage cracks. Mortar should be used within approximately 30 minutes of final mixing, and "retempering," or adding more water, should not be permitted.

Using Lime Putty to Make Mortar

Mortar made with lime putty and sand, sometimes referred to as roughage or course stuff, should be measured by volume, and may require slightly different proportions from those used with hydrated lime. No additional water is usually needed to achieve a workable consistency because enough water is already contained in the putty. Sand is proportioned first, followed by the lime putty, then mixed for five minutes or until all the sand is thoroughly coated with the lime putty. But mixing, in the familiar sense of turning over with a hoe, sometimes may not be sufficient if the best possible performance is to be obtained from a lime putty mortar. Although the old practice of chopping, beating and ramming the mortar has largely been forgotten, recent

field work has confirmed that lime putty and sand rammed and beaten with a wooden mallet or ax handle, interspersed by chopping with a hoe, can significantly improve workability and performance. The intensity of this action increases the overall lime/sand contact and removes any surplus water by compacting the other ingredients. It may also be advantageous for larger projects to use a mortar pan mill for mixing. Mortar pan mills which have a long tradition in Europe produce a superior lime putty mortar not attainable with today's modern paddle and drum type mixers.

For larger repointing projects the lime putty and sand can be mixed together ahead of time and stored indefinitely, on or off site, which eliminates the need for piles of sand on the job site. This mixture, which resembles damp brown sugar, must be protected from the air in sealed containers with a wet piece of burlap over the top or sealed in a large plastic bag to prevent evaporation and premature carbonation. The lime putty and sand mixture can be recombined into a workable plastic state months later with no additional water.

If portland cement is specified in a lime putty and sand mortar—Type O (1:2:9) or Type K (1:3:11)—the portland cement should first be mixed into a slurry paste before adding it to the lime putty and sand. Not only will this ensure that the portland cement is evenly distributed throughout the mixture, but if dry portland cement is added to wet ingredients it tends to "ball up," jeopardizing dispersion. (Usually water must be added to the lime putty and sand anyway once the portland cement is introduced.) Any color pigments should be added at this stage and mixed for a full five minutes. The mortar should be used within 30 minutes to 1½ hours and it should not be retempered. Once portland cement has been added the mortar can no longer be stored.

Filling the Joint

Where existing mortar has been removed to a depth of greater than 1 inch, these deeper areas should be filled first, compacting the new mortar in several layers. The back of the entire joint should be filled successively by applying approximately 1/4 inch of mortar, packing it well into the back corners. This application may extend along the wall for several feet. As soon as the mortar has reached thumb-print hardness, another 1/4 inch layer of mortar—approximately the same thickness—may be applied. Several layers will be needed to fill the joint flush with the outer surface of the masonry. It is important to allow each layer time to harden before the next layer is applied; most of the mortar shrinkage occurs during the hardening process and layering thus minimizes overall shrinkage.

When the final layer of mortar is thumb-print hard, the joint should be tooled to match the historic joint. Proper timing of the tooling is important for uniform color and appearance. If tooled when too soft, the color will be lighter than expected, and hairline cracks may occur; if

tooled when too hard, there may be dark streaks called "tool burning," and good closure of the mortar against the masonry units will not be achieved.

If the old bricks or stones have worn, rounded edges, it is best to recess the final mortar slightly from the face of the masonry. This treatment will help avoid a joint which is visually wider than the actual joint; it also will avoid creation of a large, thin featheredge which is easily damaged, thus admitting water. After tooling, excess mortar can be removed from the edge of the joint by brushing with a natural bristle or nylon brush. Metal bristle brushes should never be used on historic masonry.

Curing Conditions

The preliminary hardening of high-lime content mortars—those mortars that contain more lime by volume than portland cement, i.e., Type O (1:2:9), Type K (1:3:11), and straight lime/sand, Type "L" (0:1:3)—takes place fairly rapidly as water in the mix is lost to the porous surface of the masonry and through evaporation. A high lime mortar (especially Type "L") left to dry out too rapidly can result in chalking, poor adhesion, and poor durability. Periodic wetting of the repointed area after the mortar joints are thumb-print hard and have been finish tooled may significantly accelerate the carbonation process. When feasible, misting using a hand sprayer with a fine nozzle can be simple to do for a day or two after repointing. Local conditions will dictate the frequency of wetting, but initially it may be as often as every hour and gradually reduced to every three or four hours. Walls should be covered with burlap for the first three days after repointing. (Plastic may be used, but it should be tented out and not placed directly against the wall.) This helps keep the walls damp and protects them from direct sunlight. Once carbonation of the lime has begun, it will continue for many years and the lime will gain strength as it reverts back to calcium carbonate within the wall.



This 18th century pediment and surrounding wall exhibit distinctively different mortar joints.
Photo: NPS files.

Aging the Mortar

Even with the best efforts at matching the existing mortar color, texture, and materials, there will usually be a visible difference between the old and new work, partly because the new mortar has been matched to the unweathered portions of the historic mortar. Another reason for a slight mismatch may be that the sand is more exposed in old mortar due to the slight erosion of the lime or cement. Although spot repointing is generally preferable and some color difference should be acceptable, if the difference between old and new mortar is too extreme, it may be advisable in some instances to repoint an entire area of a wall, or an entire feature such as a bay, to minimize the difference between the old and the new mortar. If the mortars have been properly matched, usually the best way to deal with surface color differences is to let the mortars age naturally. Other treatments to overcome these differences, including cleaning the non-repointed areas or staining the new mortar, should be carefully tested prior to implementation.

Staining the new mortar to achieve a better color match is generally not recommended, but it may be appropriate in some instances. Although staining may provide an initial match, the old and new mortars may weather at different rates, leading to visual differences after a few seasons. In addition, the mixtures used to stain the mortar may be harmful to the masonry; for example, they may introduce salts into the masonry which can lead to efflorescence.

Cleaning the Repointed Masonry

If repointing work is carefully executed, there will be little need for cleaning other than to remove the small amount of mortar from the edge of the joint following tooling. This can be done with a stiff natural bristle or nylon brush after the mortar has dried, but before it is initially set (1-2 hours). Mortar that has hardened can usually be removed with a wooden paddle or, if necessary, a chisel.

Further cleaning is best accomplished with plain water and natural bristle or nylon brushes. If chemicals must be used, they should be selected with extreme caution. Improper cleaning can lead to deterioration of the masonry units, deterioration of the mortar, mortar smear, and efflorescence. New mortar joints are especially susceptible to damage because they do not become fully cured for several months. Chemical cleaners, particularly acids, should never be used on dry masonry. The masonry should always be completely soaked once with water before chemicals are applied. After cleaning, the walls should be flushed again with plain water to remove all traces of the chemicals.

Several precautions should be taken if a freshly repointed masonry wall is to be cleaned. First, the mortar should be fully hardened before cleaning. Thirty days is usually sufficient, depending on weather and exposure; as mentioned previously, the mortar will continue to cure even after it has hardened. Test panels should be prepared to evaluate the effects of different cleaning methods. Generally, on newly repointed masonry walls, only very low pressure (100 psi) water

washing supplemented by stiff natural bristle or nylon brushes should be used, except on glazed or polished surfaces, where only soft cloths should be used.**

New construction "bloom" or efflorescence occasionally appears within the first few months of repointing and usually disappears through the normal process of weathering. If the efflorescence is not removed by natural processes, the safest way to remove it is by dry brushing with stiff natural or nylon bristle brushes followed by wet brushing. Hydrochloric (muriatic) acid, is generally ineffective, and it should not be used to remove efflorescence. It may liberate additional salts, which, in turn, can lead to more efflorescence.

Surface grouting is sometimes suggested as an alternative to repointing brick buildings, in particular. This process involves the application of a thin coat of cement-based grout to the mortar joints and the mortar/brick interface. To be effective, the grout must extend slightly onto the face of the masonry units, thus widening the joint visually. The change in the joint appearance can alter the historic character of the structure to an unacceptable degree. In addition, although masking of the bricks is intended to keep the grout off the remainder of the face of the bricks, some level of residue, called "veiling," will inevitably remain. Surface grouting cannot substitute for the more extensive work of repointing, and it is not a recommended treatment for historic masonry.

*** Additional information on masonry cleaning is presented in Preservation Briefs 1: Assessing Cleaning and Water-Repellent Treatments for Historic Masonry Buildings, Robert C. Mack, FAIA, and Anne E. Grimmer, Washington, D.C.: Technical Preservation Services, National Park Service, U.S. Department of the Interior, 2000; and Keeping it Clean: Removing Exterior Dirt, Paint, Stains & Graffiti from Historic Masonry Buildings, Anne E. Grimmer, Washington, D.C.: Technical Preservation Services, National Park Service, U.S. Department of the Interior, 1988.*

Visually Examining the Mortar and the Masonry Units [return to top ▲](#)

A simple *in situ* comparison will help determine the hardness and condition of the mortar and the masonry units. Begin by scraping the mortar with a screwdriver, and gradually tapping harder with a cold chisel and mason's hammer. Masonry units can be tested in the same way beginning, even more gently, by scraping with a fingernail. This relative analysis which is derived from the 10-point hardness scale used to describe minerals, provides a good starting point for selection of an appropriate mortar. It is described more fully in "The Russack System for Brick & Mortar Description" referenced in [Reading List](#) at the end of this Brief.

Mortar samples should be chosen carefully, and picked from a variety of locations on the building to find unweathered mortar, if possible. Portions of the building may have been repointed in the

past while other areas may be subject to conditions causing unusual deterioration. There may be several colors of mortar dating from different construction periods or sand used from different sources during the initial construction. Any of these situations can give false readings to the visual or physical characteristics required for the new mortar. Variations should be noted which may require developing more than one mix.

1. Remove with a chisel and hammer three or four unweathered samples of the mortar to be matched from several locations on the building. (Set the largest sample aside--this will be used later for comparison with the repointing mortar). Removing a full representation of samples will allow selection of a "mean" or average mortar sample.
2. Mash the remaining samples with a wooden mallet, or hammer if necessary, until they are separated into their constituent parts. There should be a good handful of the material.
3. Examine the powdered portion—the lime and/or cement matrix of the mortar. Most particularly, note the color. There is a tendency to think of historic mortars as having white binders, but grey portland cement was available by the last quarter of the 19th century, and traditional limes were also sometimes grey. Thus, in some instances, the natural color of the historic binder may be grey, rather than white. The mortar may also have been tinted to create a colored mortar, and this color should be identified at this point.
4. Carefully blow away the powdery material (the lime and/or cement matrix which bound the mortar together).
5. With a low power (10 power) magnifying glass, examine the remaining sand and other materials such as lumps of lime or shell.
6. Note and record the wide range of color as well as the varying sizes of the individual grains of sand, impurities, or other materials.

Other Factors to Consider

Color

Regardless of the color of the binder or colored additives, the sand is the primary material that gives mortar its color. A surprising variety of colors of sand may be found in a single sample of historic mortar, and the different sizes of the grains of sand or other materials, such as incompletely ground lime or cement, play an important role in the texture of the repointing mortar. Therefore, when specifying sand for repointing mortar, it may be necessary to obtain sand from several sources and to combine or screen them in order to approximate the range of sand colors and grain sizes in the historic mortar sample.

Pointing Style

Close examination of the historic masonry wall and the techniques used in the original construction will assist in maintaining the visual qualities of the building. Pointing styles and the methods of producing them should be examined. It is important to look at both the horizontal and the vertical joints to determine the order in which they were tooled and whether they were the same style. Some late-19th and early-20th century buildings, for example, have horizontal joints that were raked back while the vertical joints were finished flush and stained to match the bricks, thus creating the illusion of horizontal bands. Pointing styles may also differ from one facade to another; front walls often received greater attention to mortar detailing than side and rear walls. **Tuckpointing** is not true repointing but the application of a raised joint or lime putty joint on top of flush mortar joints. **Penciling** is a purely decorative, painted surface treatment over a mortar joint, often in a contrasting color.

Masonry Units

The masonry units should also be examined so that any replacement units will match the historic masonry. Within a wall there may be a wide range of colors, textures, and sizes, particularly with hand-made brick or rough-cut, locally-quarried stone. Replacement units should blend in with the full range of masonry units rather than a single brick or stone.

Matching Color and Texture of the Repointing Mortar

New mortar should match the unweathered interior portions of the historic mortar. The simplest way to check the match is to make a small sample of the proposed mix and allow it to cure at a temperature of approximately 70 degrees F for about a week, or it can be baked in an oven to speed up the curing; this sample is then broken open and the surface is compared with the surface of the largest "saved" sample of historic mortar.

If a proper color match cannot be achieved through the use of natural sand or colored aggregates like crushed marble or brick dust, it may be necessary to use a modern mortar pigment.

During the early stages of the project, it should be determined how closely the new mortar should match the historic mortar. Will "quite close" be sufficient, or is "exactly" expected? The specifications should state this clearly so that the contractor has a reasonable idea how much time and expense will be required to develop an acceptable match.

The same judgment will be necessary in matching replacement terra cotta, stone or brick. If there is a known source for replacements, this should be included in the specifications. If a source cannot be determined prior to the bidding process, the specifications should include an

estimated price for the replacement materials with the final price based on the actual cost to the contractor.

Mortar Types (Measured by volume)

Designation	Cement	Hydrated Lime or Lime Putty	Sand
M	1	1/4	3 - 3 3/4
S	1	1/2	4-4 1/2
N	1	1	5-6
O	1	2	8-9
K	1	3	10-12
"L"	0	1	2 1/4-3

Suggested Mortar Types for Different Exposures

Exposure

Masonry Material	Sheltered	Moderate	Severe
Very durable: granite, hard-cored brick, etc.	O	N	S
Moderately durable: limestone, durable stone, molded brick	K	O	N
Minimally durable: soft hand-made brick	"L"	K	O

Summary and References [return to top ▲](#)

For the Owner/Administrator

The owner or administrator of a historic building should remember that repointing is likely to be a lengthy and expensive process. First, there must be adequate time for evaluation of the building and investigation into the cause of problems. Then, there will be time needed for preparation of the contract documents. The work itself is precise, time-consuming and noisy, and scaffolding may cover the face of the building for some time. Therefore, the owner must carefully plan the work to avoid problems. Schedules for both repointing and other activities will thus require careful coordination to avoid unanticipated conflicts. The owner must avoid the tendency to rush the work or cut corners if the historic building is to retain its visual integrity and the job is to be durable.

For the Architect/Consultant

Because the primary role of the consultant is to ensure the life of the building, a knowledge of historic construction techniques and the special problems found in older buildings is essential. The consultant must assist the owner in planning for logistical problems relating to research and construction. It is the consultant's responsibility to determine the cause of the mortar deterioration and ensure that it is corrected before the masonry is repointed. The consultant must also be prepared to spend more time in project inspections than is customary in modern construction.

For the Masons

Successful repointing depends on the masons themselves. Experienced masons understand the special requirements for work on historic buildings and the added time and expense they require. The entire masonry crew must be willing and able to perform the work in conformance with the specifications, even when the specifications may not be in conformance with standard practice. At the same time, the masons should not hesitate to question the specifications if it appears that the work specified would damage the building.

Conclusion

A good repointing job is meant to last, at least 30 years, and preferably 50- 100 years. Shortcuts and poor craftsmanship result not only in diminishing the historic character of a building, but also in a job that looks bad, and will require future repointing sooner than if the work had been done correctly. The mortar joint in a historic masonry building has often been called a wall's "first line of defense." Good repointing practices guarantee the long life of the mortar joint, the wall, and the historic structure. Although careful maintenance will help preserve the freshly repointed mortar joints, it is important to remember that mortar joints are intended to be sacrificial and will probably require repointing some time in the future. Nevertheless, if the historic mortar joints proved durable for many years, then careful repointing should have an equally long life, ultimately contributing to the preservation of the entire building.

Useful Addresses

Brick Institute of America

11490 Commerce Park Drive
Reston, VA 22091

National Lime Association

200 N. Glebe Road, Suite 800
Arlington, VA 22203

Portland Cement Association

5420 Old Orchard Road
Skokie, IL 60077

Acknowledgments

Robert C. Mack, FAIA, is a principal in the firm of MacDonald & Mack, Architects, Ltd., an architectural firm that specializes in historic buildings in Minneapolis, Minnesota. **John P.**

Speweik, CSI, Toledo, Ohio, is a 5th-generation stonemason, and principal in U.S. Heritage Group, Inc., Chicago, Illinois, which does custom historic mortar matching. **Anne E. Grimmer**, Senior Architectural Historian, National Park Service, was responsible for developing and coordinating the revision of this Preservation Brief, incorporating professional comments, and the technical editing.

The authors and the editor wish to thank the following for the professional and technical review they provided: Mark Macpherson and Ron Peterson, Masonry Restoration Contractors, Macpherson-Towne Company, Minneapolis, MN; Lorraine Schnabel, Architectural Conservator, John Milner Associates, Inc., Philadelphia, PA; Lauren B. Sickels-Taves, Ph.D., Architectural Conservator, Biohistory International, Huntington Woods, MI; and the following National Park Service professional staff, including: E. Blaine Cliver, Chief, Historic American Buildings Survey/Historic American Engineering Record; Douglas C. Hicks, Deputy Superintendent, Historic Preservation Training Center, Frederick, MD; Chris McGuigan, Supervisory Exhibits Specialist, Historic Preservation Training Center, Frederick, MD; Charles E. Fisher, Sharon C. Park, FAIA, John Sandor, Technical Preservation Services Branch, Heritage Preservation Services, and Kay D. Weeks, Heritage Preservation Services.

The original version of this brief, *Repointing Mortar Joints in Historic Brick Buildings*, was written by Robert C. Mack in 1976, and was revised and updated in 1980 by Robert C. Mack, de Teel Patterson Tiller, and James S. Askins.

This publication has been prepared pursuant to the National Historic Preservation Act of 1966, as amended, which directs the Secretary of the Interior to develop and make available information concerning historic properties. Technical Preservation Services (TPS), National Park Service prepares standards, guidelines, and other educational materials on responsible historic preservation treatments for a broad public.

October 1998

Reading List [return to top ▲](#)

Ashurst, John & Nicola. *Practical Building Conservation. Vol. 3: Mortars, Plasters and Renders*. New York: Halsted Press, a Division of John Wiley & Sons, Inc., 1988.

Cliver, E. Blaine. "Tests for the Analysis of Mortar Samples." *Bulletin of the Association for Preservation Technology*. Vol. 6, No. 1 (1974), pp. 68-73.

Coney, William B., AIA. *Masonry Repointing of Twentieth-Century Buildings*. Illinois Preservation Series. Number 10. Springfield, IL: Division of Preservation Services, Illinois Historic Preservation Agency, 1989.

Davidson, J.I. "Masonry Mortar." *Canadian Building Digest*. CBD 163. Ottawa, ONT: Division of Building Research, National Research Council of Canada, 1974.

Ferro, Maximillian L., AIA, RIBA. "The Russack System for Brick and Mortar Description: A Field Method for Assessing Masonry Hardness." *Technology and Conservation*. Vol. 5, No. 2 (Summer 1980), pp. 32-35.

Hooker, Kenneth A. "Field Notes on Repointing." *Aberdeen's Magazine of Masonry Construction*. Vol. 4, No. 8 (August 1991), pp. 326-328.

Jedrzejska, H. "Old Mortars in Poland: A New Method of Investigation." *Studies in Conservation*. Vol. 5, No. 4 (1960), pp. 132-138.

"Lime's Role in Mortar." *Aberdeen's Magazine of Masonry Construction*. Vol. 9, No. 8 (August 1996), pp. 364-368.

Phillips, Morgan W. "Brief Notes on the Subjects of Analyzing Paints and Mortars and the Recording of Moulding Profiles: The Trouble with Paint and Mortar Analysis." *Bulletin of the Association for Preservation Technology*. Vol. 10, No. 2 (1978), pp. 77-89.

Preparation and Use of Lime Mortars: An Introduction to the Principles of Using Lime Mortars. Scottish Lime Centre for Historic Scotland. Edinburgh: Historic Scotland, 1995.

Schierhorn, Carolyn. "Ensuring Mortar Color Consistency." *Aberdeen's Magazine of Masonry Construction*. Vol. 9, No. 1 (January 1996), pp. 33-35.

"Should Air-Entrained Mortars Be Used?" *Aberdeen's Magazine of Masonry Construction*. Vol. 7, No. 9 (September 1994), pp. 419-422.

Sickels-Taves, Lauren B. "Creep, Shrinkage, and Mortars in Historic Preservation." *Journal of Testing and Evaluation, JTEVA*. Vol. 23, No. 6 (November 1995), pp. 447-452.

Speweik, John P. *The History of Masonry Mortar in America, 1720-1995*. Arlington, VA: National Lime Association, 1995.

Speweik, John P. "Repointing Right: Why Using Modern Mortar Can Damage a Historic House." *Old-House Journal*. Vol. XXV, No. 4 (July-August 1997), pp. 46-51.

Technical Notes on Brick Construction. Brick Institute of America, Reston, VA.

"Moisture Resistance of Brick Masonry: Maintenance." 7F. February 1986.

"Mortars for Brick Masonry." 8 Revised II. November 1989.

"Standard Specification for Portland Cement-Lime Mortar for Brick Masonry." 8A Revised. September 1988.

"Mortar for Brick Masonry-Selection and Controls." 8B Reissued. September 1988. (July/August 1976).

"Guide Specifications for Brick Masonry, Part V Mortar and Grout." 11E Revised. September 1991.

"Bonds and Patterns in Brickwork." 30 Reissued. September 1988.



nps.gov

EXPERIENCE YOUR AMERICA™



nps.gov

EXPERIENCE YOUR AMERICA™

- [DOI](#)
- [Frequently Asked Questions](#)
- [Website Policies](#)
- [TPS Home](#)
- [Contact TPS](#)

[Home](#) > [How to Preserve](#) > [Preservation Briefs](#) > 38 Removing Graffiti

Some of the web versions of the Preservation Briefs differ somewhat from the printed versions. Many illustrations are new and in color; Captions are simplified and some complex charts are omitted. To order hard copies of the Briefs, see [Printed Publications](#).

PRESERVATION BRIEFS

38



Poultice to remove pig graffiti. Photo: NPS files.

Removing Graffiti from Historic Masonry

Martin E. Weaver

- [Identifying the Graffiti and the Masonry](#)

- [Graffiti Removal Methods and Materials](#)
- [Testing](#)
- [Health and Safety Considerations](#)
- [Environmental Considerations](#)
- [Barrier Coatings](#)
- [Preventing and Controlling Graffiti](#)
- [Development of a Treatment Plan](#)
- [Selecting a Barrier Coating](#)
- [Tips for Successful Graffiti Removal](#)
- [Summary and References](#)
- [Reading List](#)
- [Download the PDF](#)

Removing graffiti as soon as it appears is the key to its elimination—and recurrence.

Thus, the intent of this Preservation Brief is to help owners and managers of historic masonry structures find the best way to remove exterior, surface-applied graffiti* quickly, effectively, and safely. The Brief will discuss the variety of materials used to apply graffiti, and offer guidance on how to remove graffiti from all types of historic masonry without harming either the surface or the substrate. Suggestions will also be given regarding the use of physical barriers to protect masonry surfaces from graffiti, and the application of barrier coatings to facilitate graffiti removal. Building managers and owners of historic properties will be advised on the importance of being prepared for rapid graffiti removal by testing different cleaning techniques in advance in order to select the most appropriate and sensitive cleaning technique. Health and safety and environmental concerns are addressed, as well as regulatory matters. Removing graffiti without causing damage to historic masonry is a job for trained maintenance crews, and in some cases, professional conservators, and generally should not be attempted by untrained workers, property owners or building managers. Although the focus of this Preservation Brief is on historic masonry, the same guidance may be applied equally to removing graffiti from non-historic masonry.

Identifying the Graffiti and the Masonry [return to top ▲](#)

Successful graffiti removal from historic masonry depends on achieving a balance between breaking the bond between the graffiti and the masonry surface without damaging the masonry. This generally requires knowledge both of the materials used to make the graffiti and the masonry on which the graffiti has been executed, as well as knowledge of cleaning methods and materials. Without this, masonry surfaces can be badly disfigured or damaged during graffiti removal.

*The word *graffito* (*graffiti*, plural)—is derived from the old Italian diminutive of *graffio*-to scratch, and the Latin *graphire*-to write. *Graffiti* in contemporary usage has come to mean an inscription, drawings, or markings. Except in very formal or technical applications, graffiti is generally considered a "mass" noun and paired with a singular verb.



Inappropriate abrasive blasting to remove the graffiti has permanently etched the graffiti into the stone. Photo: NPS files.

Graffiti

Most graffiti is made with spray paints. Although a number of solvents and paint strippers are capable of dissolving or breaking down these paints, some may permanently discolor or stain the masonry surface if not used correctly. As a result, the remaining paint may become more difficult, or even impossible, to remove. Poorly thought-out and generally hasty attempts to remove graffiti using harsh chemicals or abrasives can also cause permanent damage to the masonry that may be worse than the graffiti.



Removing this densely painted graffiti will require several applications of paint remover. Photo: NPS files.

The ability to identify the graffiti material is an important step in successful removal. Numerous kinds of spray paint (polyurethanes, lacquers, and enamels), and brush-applied paints (oils and synthetic resins such as vinyls, acrylics, acetates, methacrylates, or alkyds), as well as permanent felt markers are the materials most often used to make graffiti. But other materials are also used for graffiti, including water-soluble felt markers, ballpoint pens, chalk, graphite and colored pencils, pastels, wax and oil crayons, liquid shoe polish, and lipstick. The range of materials adopted by graffitiists continues to expand.

Paints are composed of pigments that provide color and hiding power; binder that holds the pigments together and to the substrate; and a solvent that allows the pigment/binder mixture to flow. Some spray paints and markers may contain dyes instead of pigments. Paints are applied wet. Generally, as the solvent evaporates, the binder solidifies. The greater the solvent content of the paint, the greater the flow rate, and thus, the greater the ability of the paint to penetrate into masonry pores.

The two primary components contained in most graffiti materials—pigment or dye, and binder—may simply remain on the masonry surface, or penetrate into the masonry to varying depths depending on a number of factors, including the surface tension of the substrate and viscosity of the solvent or vehicle. Thus, even the total removal of the pigment or the binder may leave residues of the other component actually in, or below, the surface of the stone. Residual stains, or graffiti "ghosts," such as those from any kind of red paint or the fine black pigments used in spray paints, may be particularly difficult to remove.

With painted graffiti, it is helpful to establish how long it has been on the surface. For most paints that have been on the surface for several weeks or months, hardening processes are likely to be complete or well-advanced; the solubility of the paint is proportionately reduced and it will be more difficult to remove.

Masonry

The historic masonry substrate must also be identified. As used here, the term *masonry* encompasses all types of natural stones; manufactured clay materials, including brick and terra cotta; and cementitious materials, such as cast stone, concrete and mortar. The common factor among masonry materials is that they are porous, to a greater or lesser extent, and sensitive to abrasion. After identifying the masonry, its condition, including fragility, porosity and permeability, must also be assessed prior to beginning graffiti removal. For example, a smooth, newly-polished granite surface is comparatively easy to clean because it is relatively impermeable and paint vehicles tend to stay on the surface rather than penetrate into microscopic pores. A very smooth, polished surface also has no pits or crevices that will retain particles of pigment or binder. In contrast, weathered marble or limestone may be extremely porous and permeable, with a rough surface on which particles of pigment can easily lodge. The

fragility of such a surface can make it impossible to clean the surface even with a bristle brush without risking severe surface loss. A difference in surface texture or finish may also be the reason that a particular cleaning agent will work in one situation but not another.



Spray painted graffiti defaces this historic brick building. Photo: NPS files.

Some types of masonry may react adversely to contact with the various cleaning agents required to break or dissolve the bond between the graffiti and the masonry surface. Thus, for purposes of cleaning, masonry types are often categorized according to whether they are acid-sensitive, non-acid sensitive, or alkali-sensitive. *Acid-sensitive* stones consisting of carbonate materials may be damaged or even destroyed by contact with acids. Although, in many instances, acidic cleaning compounds are not effective for graffiti removal and generally should not be used for this purpose, it is useful to know that some acid-sensitive materials include: stones such as limestone, marble, travertine, calcareous sandstones and shales; most polished stones; and glazed architectural terra cotta and glazed brick. Non-acid sensitive masonry materials include slate, granite, unglazed architectural terra cotta and unglazed brick. Alkali-sensitive stones may contain silicates, or ferrous, soluble iron compounds that can react with alkalis or water to form severe staining. *Alkali-sensitive* stones include some granites, Indiana limestone, and many types of sandstone, especially those that are green or grey in color. Glazed and polished surfaces tend to be damaged by both strong acids and strong alkalis.

Graffiti Removal Methods and Materials [return to top ▲](#)



A poultrice is often the preferred method of graffiti removal. Photo: NPS files.

A variety of treatments are available from which to choose the most appropriate method of graffiti removal that will not damage the surface of historic masonry. Removal techniques, which are chosen according to the type of graffiti and the masonry, range from simply erasing pencilled graffiti with soft erasers, or removing chalked graffiti with soft brushes, to poulticing with water (with or without detergents), poulticing with organic solvents or alkali-based paint removers, or applying bleach to remove painted graffiti. In very limited situations, it may mean using very delicate and controlled abrasive means. Successful graffiti removal often requires a combination of cleaning materials and methods.

Poulticing

The most effective method of removing graffiti from masonry usually involves the use of a poultice. A poultice consists of an absorbent material or powder-inert clays such as kaolin or sepiolite, diatomaceous earth (fuller's earth); or cellulose products such as fluff pulp cellulose or shredded paper-mixed with a cleaning solution (a liquid reagent such as water, organic solvent, paint stripper or bleach) to form a paste or slurry. The purpose of a poultice is twofold: it enables a cleaning solution to be kept in contact with the stained area as long as possible, while allowing the cleaning solution to pull the staining material out of the substrate via the poultice without redepositing it in, or restaining, the masonry. A poultice is often covered with a plastic sheet to retard evaporation. With some extremely porous types of stone, such as marble, although a poultice may remove a stain from one side of the stone, stains can pass completely through the stone and be redeposited on the other side of the masonry slab. Thus, caution should always be exercised in stain and graffiti removal.



Painting over graffiti on stone is not a recommended maintenance treatment. Photo: NPS files.

Water and Detergent

Graffiti removal from historic masonry should always begin with the gentlest means possible. In some instances, this means low-pressure water washing. Fresh graffiti—one or two days old—made with water-soluble markers may sometimes be removed with water, possibly aided by a neutral or non-ionic detergent. (Non-ionic detergents which do not ionize in solution, do not deposit a solid, visible residue.) Ammonia can also be effective in removing fresh graffiti. Any detergent should be approached with caution and tested before using because most commercial laundry detergents are not neutral and contain substances which may leave undesirable residues on masonry materials. Usually, the water and detergent should be mixed with an absorbent material and applied in the form of a poultice. Although water washing is often likely to be the gentlest cleaning method for historic masonry, it may not be as effective for removing graffiti because many graffiti materials are not soluble in water.

Organic Solvents and Paint Removers

Most graffiti can be removed without damaging the masonry with proprietary graffiti-removal products and commercial paint strippers containing organic solvents. But, these products should always be tested and used in accordance with manufacturer's instructions included in the product literature. Normally, solvents should be used in a poultice form to prevent them from penetrating into the substrate, and permanently discoloring or staining the masonry. A number of paint-removers are manufactured as thick gels or pastes that cling to the surface, and some commercial paint-removal products include a tough fiber-reinforced paper or cloth backing that retards evaporation and also facilitates neat and clean removal of the used stripper. The advantage of using organic solvents is that they evaporate completely, leaving no residual material in the masonry. However, organic solvents may present a severe health hazard, and workers using them must wear adequate protection. "Off-the-shelf" aerosol graffiti removers generally should not be used because the dissolved paint being removed may run down the wall

"staining" a previously clean area; or pigments may also be redistributed by the rinsing and scrubbing recommended by the product manufacturer.

Alkaline Compounds

Alkaline compounds may be used to remove some oils and greases, and waxes from *non-alkali sensitive* masonry. Like organic solvents, alkaline compounds should generally be used in conjunction with a poultice when removing graffiti. The use of alkaline compounds should always be followed by a weak acid wash and a water rinse in order to neutralize-or remove-all the alkaline residues from the masonry. Strong alkalies (pH13-14), such as sodium hydroxide-based paint removers (caustic soda or lye), generally should not be used as they can cause efflorescence and staining on masonry surfaces, if not properly neutralized. Potassium and other hydroxide paint removers may react with iron compounds in some masonry, particularly Indiana limestone, to form dark brown (rust-colored), or black ferric hydroxide stains, which are very difficult to remove.

Bleaches

Alkali-based bleaches such as calcium hypochlorite can sometimes be used very successfully in a poultice to bleach or decolorize certain dyes contained in some paints and inks that cannot readily be removed by other means.



Damaging graffiti removal methods have scarred the marble. Photo: NPS files.

Mechanical or Abrasive Methods

Mechanical treatments include dry or wet blasting, using abrasive grits, such as sand, dolomite powder, aluminum oxide, ground-walnut shells, sodium bicarbonate (baking soda), and others; high-pressure water washing; and mechanical sanding or grinding. All of these abrasive methods will cause damage to masonry and, in most instances, should never be considered as a method

of removing graffiti from historic masonry. Abrasive methods used mistakenly by untrained workers to remove graffiti usually result in etching the outline of the graffiti permanently into the masonry. Some historic masonry materials can be easily damaged by pressure washing even at low or moderate pressures (100-400 psi). Occasionally, however, under very controlled circumstances, a micro-abrasive technique may be appropriate for removing graffiti from delicate masonry surfaces, if used at low pressures of 35-40 psi with fine abrasives. This treatment, which must be done very slowly and carefully to avoid damaging the masonry, should be tested first, and undertaken only by a professional conservator. Another exception, even though it is not strictly an abrasive treatment, is using a razor blade as a first step to remove spray paint or felt-tip marker from polished granite. However, this too, should be undertaken only by a *professional conservator*, and only on *polished granite*, which is very hard and generally impervious to scratches.

Laser Cleaning

Although not in general use as a cleaning technique, laser technology offers great promise in the future as a non-damaging method of graffiti removal.

Testing [return to top ▲](#)

Before selecting a removal method, all cleaning materials and techniques for removing graffiti from a historic masonry building should be tested on mock-ups or areas of the resource that are not highly visible, but which are representative of typical conditions. Visual observation should be supplemented by the use of a magnifying glass, and spot tests should be carried out with various solvents to help identify the specific graffiti medium, which will aid in its removal. More complex testing using laboratory equipment and more scientific analytical processes may sometimes be necessary in complex situations. Sample areas that represent the desired degree of "cleanliness" should be approved in writing by client, architect, conservator or other appropriate authority. The materials and all the other data necessary to reproduce the desired cleaning results should be meticulously recorded and the accepted sample area preserved for reference until the end of the job. The existence of a "clean" sample for comparison and a signed agreement can avoid unpleasant surprises, misunderstandings, and perhaps legal actions.

When a type of graffiti appears for the first time that was executed with a material not immediately recognizable and for which no countermeasures have been developed, tests may need to be carried out by an architectural conservator to identify the material and to determine effective removal treatments. Agencies with large inventories of graffiti-prone buildings and structures should watch for graffiti made with new materials and experiment with different cleaning methods in order to be prepared when it appears. Such early action can save large sums of money in the long term. (See "Development of a Treatment Plan.")

Health and Safety Considerations

[return to top ▲](#)

Most of the chemicals used for graffiti removal are dangerous to workers, as well as to others who may be in the vicinity. Organic solvents are toxic by ingestion, inhalation, and skin contact. Material Safety Data Sheets (MSDS), available from the product manufacturer for all paint-removal products, should always be consulted and followed. Identification of hazardous components and checking with chemical reference works will help assure that the least hazardous, but most effective, products are selected.

Generally speaking, it is a sensible policy to carry out all graffiti removal in well-ventilated conditions. Some solvents can be used only outdoors, and sometimes forced ventilation may be necessary even there, requiring workers to use air-fed respiratory equipment to avoid wind-blown fumes. Smoking, eating or drinking must not be allowed when cleaning is in progress.

Some materials used for graffiti removal are so corrosive that accidental contact can cause serious, permanent scarring and painful injuries. Wearing appropriate protective clothing must be strictly enforced. Mandatory personal protective equipment (PPE) normally includes face shields or safety glasses; long, chemical-resistant gloves; face masks with respirators for organic solvents; and possibly, full protective clothing with an independent air supply.

All smoking and open flames should be rigorously excluded from work areas; many solvents are flammable or highly explosive in vapor or liquid form when mixed with air. Solvent residue, used swabs, cloths, overalls and all other solvent-contaminated items should be safely and legally disposed of, or properly stored-even overnight-away from potential sources of fire. Electrical equipment may require explosion-proof fittings when used with certain solvents.

When electric pumps and pressure-spraying equipment are used, it is especially important that all necessary precautions be taken to avoid electric shock. Water sprays and puddles on the ground present a potentially dangerous situation, if they come into contact with temporary wiring at worksites where graffiti is being removed. Such hazards must be carefully monitored and controlled.

As with any construction project, attention should always be directed toward the general safety of the workers and passers-by, but also toward possible damage to the resource itself that might result from careless placement of ladders, or scaffolding. Chemicals used for masonry cleaning can also damage adjacent metals, glass, and painted surfaces, as well as vegetation. Product manufacturers' instructions should always be closely followed to avoid such inadvertent "collateral" damage.

Environmental Considerations [return to top ▲](#)

To protect against environmental contamination, including the formation of unwanted ozone at ground level and damage to the ozone layer in the earth's outer atmosphere, legislation has been enacted in some states making it illegal to use even moderate quantities of some solvents—*volatile organic compounds* (VOCs) contained in paint removers. In response to this legislation, many new products are being developed that do not contain VOCs.

After completing graffiti removal, the disposal of chemical products and rinsing effluent must be taken into account. Arrangement for disposal of the cleaning waste should be made prior to beginning graffiti removal, especially if it is a project of considerable size. In many places it is illegal to discharge solvents and/or paint residues into sewers or storm drains. The owner or manager of a historic property, or in some cases the individual or firm doing the cleaning or graffiti removal, is responsible for being informed of, and complying with, relevant laws and regulations. Under provisions of the National Historic Preservation Act of 1966, as amended, approval may be required from a state or federal preservation agency before any work can be undertaken on buildings or structures listed in or eligible for listing in the National Register of Historic Places, if such a project involves federal funding or licensing. Many state and local historic district commissions and review boards have their own regulations that require approval for cleaning or graffiti removal work that is undertaken on landmarks or properties in locally designated historic districts.

Barrier Coatings [return to top ▲](#)

Anti-graffiti or barrier coatings are intended to facilitate the removal of graffiti from porous as well as non-porous surfaces. These coatings are most commonly transparent, but may also be pigmented. They are available in a variety of formulations designed to serve different needs. The use of barrier coatings to protect graffiti-prone historic masonry surfaces may seem to be an easy preventive solution to a persistent graffiti problem. However, for the most part, these coatings are not the panacea that some advertising might suggest. Some of them simply do not work, and others may cause physical or aesthetic changes or damage to the masonry.

Transparent Coatings

Transparent coatings serve as a barrier between the masonry surface and graffiti, preventing graffiti from penetrating into the masonry. They are also intended to make graffiti removal easier since most graffiti does not adhere well to them. Generally, graffiti applied over transparent barrier coatings can be removed with low-pressure water and a detergent, or with a solvent.



The difference in color between the bottom and the top of the stone spandrel is the only clue to the presence of a clear barrier coating. Photo: NPS files.

There are basically two kinds of transparent barrier coatings: temporary and permanent. Temporary, or "sacrificial" coatings are removed when graffiti is removed and then must be reapplied. Permanent transparent barrier coatings are more resistant to the water or solvents used to remove graffiti, and remain on the masonry surface when graffiti is removed (although this type of coating also must usually be reapplied after several cleanings). A third type of transparent barrier coating combines temporary and permanent coatings, based on a two-part system. A water-based acrylic sealer is first applied to the masonry surface, after which a sacrificial layer consisting of a polyethylene wax emulsion or dispersion coat is applied over the sealer. When graffiti is removed, the sealer coat remains on the masonry, but the sacrificial coat dissolves and is removed with the graffiti, and thus must be reapplied. (With this two-part system, even the first coat will eventually wear off after multiple cleanings, and must also be reapplied.)

Unfortunately, in application, there are a number of negative aspects of transparent barrier coatings that generally prevent their being recommended for use on historic masonry. First, clear coatings may alter the color of the masonry surface and add a gloss that may be highly visible, or apparent only in certain lighting conditions or when it rains. Second, clear coatings may reduce the water-vapor permeability of the masonry, thereby contributing to possible water-related deterioration. Third, the coating may discolor and change over time. Exposure to ultra-violet light can cause a coating to yellow; dirt build-up may darken the treated surface; and some coatings acquire a sheen when rubbed or brushed against. Such changes are especially noticeable when only a portion of the building has been coated. Furthermore, if coatings are not maintained on a regular basis, usually through periodic removal and reapplication, many coatings tend to fail. What often results is an uneven, "patchy" look to the masonry that can have a very negative impact on the character of the historic building.

Despite these potential drawbacks, there may be some instances in which the graffiti problem or frequency of occurrence is so severe that application of a transparent barrier coating on historic

masonry may be worth considering. Some water-base polysaccharide coatings, and silicone and silicone-base coatings have been used with success on masonry structures. They are essentially invisible, and do not change the natural appearance of the masonry. Although less durable than solvent-borne coatings, they are water-vapor permeable (breathable), and may be reapplied to the masonry surface immediately after removing graffiti, while the surface is still damp.

However, extreme caution must be exercised before applying a transparent barrier coating. Experimental test applications should always be tried first on discrete areas that are not highly visible, and the treated areas evaluated over a period of time. Laboratory test results on the performance of coatings applied to samples of like masonry types may be useful to some extent. But because the tests are carried out in a controlled environment, they may not be as accurate or reliable as tests actually carried out on-site where the factors of weather and pollution are the same as those at the location where the coating will be used. If circumstances warrant, and the use of a barrier coating is determined necessary, an architectural conservator should evaluate the test performance of a variety of coatings before selecting one to be applied to historic masonry. Because of the potential for disfigurement, owners of landmark-designated buildings are required by some preservation review boards and landmark commissions to obtain approval before they apply a barrier coating.

Pigmented Coatings

A pigmented barrier coating may be used on masonry as a *permanent*, preventive barrier coating, or as a *temporary* means of concealing graffiti until it can be removed.



This formerly clear barrier coating is very shiny and has discolored as it has aged. Photo: NPS files.

Like a transparent barrier coating, a pigmented barrier coating facilitates the removal of graffiti because graffiti does not adhere well to it. Pigmented barrier coatings that are water-vapor

permeable may sometimes be used as a permanent barrier coating on non-historic masonry where there is frequent recurrence of graffiti, and when constant surveillance is not possible. Although there are some instances in which pigmented barrier coatings may be appropriate on painted historic masonry, they are not recommended for unpainted historic masonry because they will change the appearance of the masonry. There is also another kind of pigmented coating that is specially formulated to be used as a temporary measure to conceal graffiti that cannot be removed right away. This temporary, vapor-permeable paint is removed when the graffiti is removed.

Pigmented coatings are also not generally recommended as a permanent measure to cover up graffiti. Some graffiti materials, particularly felt markers, bleed through the coating; and repeated applications of the coating or paint can result in a heavy paint build-up on a masonry surface. Another disadvantage of using paint or a pigmented coating to hide graffiti is that it usually appears as an obvious patch on unpainted masonry and tends to attract more graffiti unless the paint can be applied in a discrete, and well-defined area. If incompatible with either the masonry or the graffiti, such a coating may peel off the masonry surface in an unsightly manner. Like transparent coatings, pigmented coatings may be difficult or impossible to remove completely once their performance or appearance is no longer satisfactory.

Preventing and Controlling Graffiti

[return to top ▲](#)

Experience shows that prompt removal of graffiti is one of the most effective measures against its recurrence. Graffiti that is not removed quickly tends to attract more graffiti. Often motivated by a need to have their work seen, graffiti artists tend to be discouraged from repeating their efforts in a location where their work is quickly removed.

Apart from removal, effective graffiti-prevention measures can be considered under two headings. The first consists of physical measures involving maintenance, lighting, security and the erection of barriers on or around the property itself. The second focuses on community awareness programs that include neighborhood patrols, community service programs and educational programs in the schools.

Maintenance and Security

Neglect invites vandalism, whereas a well-maintained property encourages civic pride. Thus, careful attention should be given to establishing regular maintenance programs which do not allow properties to reach a point of obvious deterioration or abandonment. Cyclical maintenance also makes good sense economically.

Graffiti is less likely to occur if graffitists can be clearly seen. It is often recommended that accessible, graffiti-prone areas be illuminated with floodlighting or spotlights. Graffiti may also be reduced or prevented by the presence of security guards, park rangers or police officers, or by the visible presence of surveillance cameras. Publicity about arrests and punitive measures against the graffitists, and the general vigilance of the security system may also reduce graffiti.

If they are historically appropriate and compatible with the historic property, soft barriers in the form of low, possibly thorny, shrubs and bushes or other forms of landscaping and planting may be effective deterrents. Such plantings can make it difficult to reach the property by any route other than the approved secure one. Hard barriers provided by fences and transparent screens or shields, such as clear acrylic or other polycarbonate sheets, may also afford some degree of protection. But these can have a negative aesthetic impact on the property's appearance, particularly if the barriers themselves become disfigured by graffiti.

Community Awareness

Community action and education often play an important role in a successful anti-graffiti program. Neighborhood watches can effectively deter graffitists, and can help police and other security agencies in the detection and prevention of graffiti. Intensive public campaigns against graffiti, including presentations in schools, developing programs to foster community pride, and sentencing offenders to remove graffiti in their own community can also be useful. Publicity concerning arrests of graffitists can be a useful preventive tool. (But, on the other hand, frequent newspaper coverage of graffiti outbreaks or even of new community efforts at deterring graffiti can sometimes have the opposite effect by challenging the "creativity" of graffitists.) Community groups trained in proper cleaning techniques can also assist property owners in prompt and non-damaging graffiti removal.

Development of a Treatment Plan

[return to top ▲](#)

For managers or owners of historic masonry buildings, or agencies responsible for large inventories of graffiti-prone properties, including parks, highway and railroad bridges and viaducts, bus, train and subway stations, and cemeteries, the development of a treatment plan may be the first step toward an effective graffiti-removal program. It is becoming increasingly common for large or important historic properties to have regular maintenance and disaster plans that include graffiti removal.

When feasible, a separate treatment plan should be prepared for each structure. However, if this is not possible, it is advisable to prepare a variety of treatment plans for specific masonry types.

Plans should be prepared to cover all types of masonry that fall under one jurisdiction, management or ownership that are potential targets for graffiti.

Guidance contained in treatment plans should be based on the results of carefully controlled testing to remove a wide variety of common graffiti materials safely, and without damaging the various types of masonry. Individual treatment plans should address all parts of the building or structure that could be disfigured by graffiti, and any features too fragile to be cleaned by anyone other than a conservator should be noted on the plan.

A treatment plan is essentially a cleaning specification, but it should also include information on the following:

- the types and conditions of masonry likely to be targeted by graffiti;
- methods, materials and techniques known to work most successfully in the removal of specific types of graffiti from the surface of each type of masonry;
- sources for materials;
- a list of contractors with expertise in graffiti removal, including names, telephone numbers, information on emergency access to the property, and storage location of materials;
- graffiti-removal methods which may be harmful to the masonry surface;
- contractors or consultants who are **not acceptable** and should not be considered for graffiti removal;
- scaffolding, pumps, or safety equipment that might be required, where it is available, and costs involved; and
- health and safety concerns regarding specific removal treatments, product literature and Material Safety Data Sheets (MSDS).

Criteria to Consider Before Selecting a Barrier Coating as the Primary Protective Means of Combating Graffiti [return to top ▲](#)

What to look for in a Barrier Coating:

- Water-vapor permeable, or "breathable".
- "Invisible" without gloss or sheen, when applied to masonry.

- No change in appearance from uncoated areas when masonry is wet.
- Does not discolor or attract dirt.
- Weathers evenly.

Questions to Ask:

- Will the coating last long enough to offset its cost?
- Will the application and reapplication of the coating be cost effective?
- Will the coating be effective against more than one type of graffiti?
- Can the coating be completely and thoroughly removed, so that, if necessary, paint, or another coating will adhere to the masonry surface?
- Will the building ever need to be repointed or patched? A barrier coating may make this difficult or even impossible.

Before Application:

- Seek advice of an architectural conservator.
- Test coating on an inconspicuous area of masonry, or study the success/failure of the coating in other locations where it has been used.

Tips for Successful Graffiti Removal [return to top ▲](#)

- It is important to pre-wet the masonry surface when using an alkaline paint remover; it is also advisable to pre-wet the masonry surrounding a graffitied area to dilute the effect of any cleaning agents that might be inadvertently splashed or spilled on the unsoiled surface. **Do not wet the area to be cleaned if the cleaning agent is solvent-based or incompatible with water.**
- Always rinse the cleaning agent off the masonry surface starting at the bottom and moving up. This prevents the cleaning agent from running down and staining a lower surface.
- Air temperature can be a factor in graffiti removal. Most paint removers do not work when the air temperature is either very cold or very hot. This may sometimes explain why a method that worked in one instance may not be effective again in another, similar situation.

- Variations within the same type of stone, such as bedding planes, density, finish, or degree of weathering, may explain why some areas of the same stone sometimes clean better than others.
- Even if advance testing has been done and a treatment plan exists, at least some on-the-spot testing will probably be necessary.
- Mortar joints react differently from masonry units, and may require a different cleaning material and/or method to be cleaned effectively.
- Graffiti removal may result in an obviously "clean" spot. Always clean the entire masonry unit that is bounded by mortar joints (but not the joints themselves, unless necessary). The prominence of the clean spot may be minimized by fanning the cleaning out from the spot, and "feathering" it by gradually reducing the strength or thoroughness of the cleaning.
- If it is not possible to completely remove all traces of graffiti without removing some of the masonry surface, it may be preferable to leave the masonry alone. Some graffiti ghosts become less noticeable with time due to fading of the dyes used in paints and markers. Sometimes it may be possible to conceal more obvious graffiti ghosts with carefully-matched paint.
- After graffiti removal, the masonry surface should always be tested with Ph strips to make sure all the cleaning materials have been completely removed. Non-staining Ph strips, available from chemical supply companies, will indicate whether acids or alkalis remain on the masonry surface.
- Although alkaline paint removers are sometimes ineffective on modern formulations of aerosol paints, they can work well in removing multi-layered graffiti because they last longer.
- What removes graffiti in one instance may not always work again even in what appears to be an identical situation.
- More than one cleaning material and technique may be required to clean a heavily graffitied area if different materials were used to make the graffiti. For example, shapes are often outlined with broad-tipped felt markers and then filled in with spray paint.
- Effective graffiti removal often depends on trial-and-error testing, as well as a knowledge of masonry materials, graffiti materials and cleaning techniques.

Summary and References [return to top ▲](#)

Although rapid graffiti removal is the most effective weapon in eliminating graffiti and preventing its recurrence in the same location, hasty, untested removal attempts can disfigure and cause harm to historic masonry. Thus, it is important that the owner or manager of a historic masonry building or structure be prepared with a plan to ensure the prompt removal of graffiti when it occurs. Regularly scheduled maintenance and cleaning programs to eliminate graffiti from historic masonry properties may be assisted by the installation of physical barriers, security systems and lighting, as well as increased community involvement. Successful graffiti removal from historic masonry requires knowledge of a variety of cleaning methods and materials, and an awareness that what works to remove graffiti from one kind of masonry surface may not remove it from another. By testing different cleaning methods in advance, treatment plans will be available, when needed, to provide guidance for safe and sensitive graffiti removal from historic masonry.

Acknowledgements

This Preservation Brief was developed under a cooperative agreement between the New York Landmarks Conservancy and the National Park Service. **Mark A. Weber**, Director, Technical Services Center, served as project coordinator for the Conservancy. The author, **Martin E. Weaver**, is the Director of the Center for Preservation Research at Columbia University. He is an internationally recognized expert in the conservation of architectural and cultural resources, a noted lecturer, and author of *Conserving Buildings: A Guide to Techniques and Materials*, as well as numerous articles on the subject.

Anne E. Grimmer, Senior Architectural Historian, Technical Preservation Services, Preservation Assistance Division, National Park Service, coordinated the development of this Preservation Brief and served as Technical Editor. Technical review of this publication by the following is gratefully acknowledged: Frances Gale, Training Coordinator, National Center for Preservation Technology and Training, National Park Service, Natchitoches, LA; Judith M. Jacob, Architectural Conservator, Building Conservation Branch, Northeast Cultural Resources Center, National Park Service, NY, NY; Andrea Mones-O'Hara, Regional Historic Preservation Officer, National Capital Region, General Services Administration, Washington, DC; Nicolas F. Veloz, Conservator of Outdoor Sculpture and Monuments, National Capital Area Office, National Park Service, Washington, DC; and Michael J. Auer, Timothy Buehner, Charles E. Fisher, and especially Kay D. Weeks, Preservation Assistance Division, National Park Service.

This publication has been prepared pursuant to the National Historic Preservation Act of 1966, as amended, which directs the Secretary of the Interior to develop and make available information concerning historic properties. Technical Preservation Services (TPS), National Park Service prepares standards, guidelines, and other educational materials on responsible historic preservation treatments for a broad public.

Reading List [return to top ▲](#)

American Geological Institute. *AGI Glossary of Geology and Related Sciences*. Washington, D.C.: American Geological Institute, 1960.

Ashurst, Nicola. *Cleaning Historic Buildings. Vol. I: Substrates, Soiling and Investigations; Vol. II: Cleaning Materials and Processes*. London: Donhead Publishing Ltd., 1994.

"Chemistry Leaves Its Mark on Graffiti." *Chemical Marketing Reporter*. November 14, 1993.

Ehrenkrantz and Eckstut Architects, P.C. *Technical Tips: Removing Graffiti*. New York: New York Landmarks Conservancy, n.d. (1994).

Graffiti Removal Manual. Providence, RI: Keep Providence Beautiful, September 1986.

Grimmer, Anne E. *Keeping it Clean: Removing Exterior Dirt, Paint, Stains and Graffiti from Historic Masonry Buildings*. Washington, D.C.: Preservation Assistance Division, National Park Service, U.S. Department of the Interior, 1988.

Lewis, Richard J. *Hazardous Chemicals Desk Reference*. Second Edition. New York: Van Nostrand Reinhold, 1991.

NIOSH Pocket Guide to Chemical Hazards. Washington, D.C.: National Institute for Occupational Safety and Health, Centers for Disease Control and Prevention, Public Health Service, U.S. Department of Health and Human Services, June 1994.

Reisner, Robert. *Graffiti: Two Thousand Years of Wall Writing*. Chicago: Cowles Book Company, 1971.

Science for Conservators: Conservation Teaching Series. The Conservation Unit of the Museums and Galleries Commission. 3 volumes. New York: Routledge, A Division of Routledge, Chapman and Hall, Inc., 1992.

Torraca, Giorgio. *Porous Building Materials*. Rome: ICCROM, 1988.

Torraca, Giorgio. *Solubility and Solvents for Conservation Problems*. Rome: ICCROM, 1990.

Weaver, Martin E. *Conserving Buildings: A Guide to Techniques and Materials*. New York: John Wiley and Sons, Inc., 1993.

Whitford, Maurice J. *Getting Rid of Graffiti: A practical guide to graffiti removal and anti-graffiti protection*. New York: Van Nostrand Reinhold, Inc., 1992.

Wollbrinck, Thomas. "The Composition of Proprietary Paint Strippers." *Journal of the American Institute for Conservation*. Vol. 32 (1993), pp. 43-57.

Young, Daniel J. *How to Comply with the OSHA Hazard Communication Standard: A Guide to Compliance with OSHA Worker Right-to-Know Regulations*. New York: Van Nostrand Reinhold, 1989.



nps.gov

EXPERIENCE YOUR AMERICA™



nps.gov

EXPERIENCE YOUR AMERICA™

- [DOI](#)
- [Frequently Asked Questions](#)
- [Website Policies](#)
- [TPS Home](#)
- [Contact TPS](#)

[Home](#) > [How to Preserve](#) > [Preservation Briefs](#) > 40 Ceramic Tile

Some of the web versions of the Preservation Briefs differ somewhat from the printed versions. Many illustrations are new and in color; Captions are simplified and some complex charts are omitted. To order hard copies of the Briefs, see [Printed Publications](#).

PRESERVATION BRIEFS

40



This Minton encaustic floor tile was installed in the U.S. Capitol in the 1850s. Photo: NPS files.

Preserving Historic Ceramic Tile Floors

Anne E. Grimmer and Kimberly A. Konrad

- [The Tile-Making Process](#)
- [Historical Background](#)

- [Ceramic Floor Tile Types](#)
- [Laying Historic Tile Floors](#)
- [Preservation and Maintenance](#)
- [Damage and Deterioration Problems](#)
- [Repair and Replacement](#)
- [Summary and References](#)
- [Reading List](#)
- [Download the PDF](#)

With a tradition that dates to ancient civilizations, *ceramic tile flooring can be found in a variety of settings in diverse cultures and structures,

including residential buildings ranging from large apartment buildings to small private houses, institutional buildings such as government offices and schools, and religious buildings such as cathedrals and mosques.

Historically, its widespread use may be attributed to the fact that a readily available natural material—clay—could be converted by a relatively simple manufacturing process—baking or firing—into a very durable, long-lasting and attractive floor tile that is easy to maintain. Ceramic floor tiles exhibit a versatility of colored glazes and decoration, and they range from the plainest terra cotta tiles to highly decorated individual ceramic tiles and elaborately patterned tile floors. Their modularity, as standardized units, make them easy to fit into different sized spaces which also explains much of the popularity of ceramic floor tiles throughout history.

**Ceramic: Any product manufactured from a nonmetallic mineral (such as clay), by firing at high temperatures.*

This Brief begins with an overview of ceramic tiles as a traditional flooring material. It includes an explanation of the various kinds of historic floor tiles used in the United States and how they were made. General guidance is given on preservation treatments, focusing on maintenance, and, when necessary, selective replacement of damaged floor tiles. The Brief is intended to provide owners and managers of historic properties with an understanding of the significance and historical background of ceramic floor tiles, and a basic awareness of maintenance techniques and various deterioration problems to which tile floors are especially prone. In the case of significant historic ceramic tile floors, a professional conservator of ceramics should be consulted to advise in matters of repair, restoration or conservation. Historically, ceramic tiles were used on walls as wainscotting, on fireplace hearths and fireplace surrounds, and even on furniture, as well as for flooring. However, because floor tiles are subject to greater damage and deterioration, they are the primary emphasis of this Brief. Highlights include: a short history of ceramic floor tiles; a description of ceramic tile types; a summary of traditional installation methods; maintenance techniques; and guidance on repair and replacement.

The Tile-Making Process [return to top ▲](#)

Clay is an earthen material, moldable or plastic when wet, non-plastic when dry, and permanently hard when baked or fired. It is widely distributed geographically, and often found mixed with sand in soils of a loam type—a mixture of clay, silt and sand. Relatively pure clay is not usually a surface deposit, although, in some cases, it may be exposed by erosion. Clay types vary throughout the world, and even within a region. Each type of clay possesses a unique combination of special properties such as plasticity, hardness and lightness, as well as color and texture, which makes some clays better suited for one kind of ceramic than another. The correct clay mixture needed for a particular purpose can be created by blending clays and adding other materials, but using the wrong type of clay can result in expensive production problems such as crazing (the formation of tiny cracks in a tile glaze) or warping of the tile itself. Traditionally, chalky clays have been preferred for many kinds of ceramic tiles, in part because they produce, when fired, a white body which is desirable for decorating. Other materials can be added, including grog (or ground-up fired clay) that helps aerate the clay and prevents warping, speeds firing and reduces shrinking, or calcined flint, to harden it.



Colored slip, or liquid clay, is being poured into the indented portion of a reproduction encaustic tile, to create the pattern. Photo: H & R Johnson Tiles.

There are several methods used for making ceramic tiles: extrusion; compaction or dust-pressing; cutting from a sheet of clay; or molded in a wooden or metal frame. Quarry tiles are extruded, but most ceramic floor tiles, including traditional encaustic, geometric and ceramic "mosaic" tiles are made from refined and blended ceramic powders using the compaction method, known as dust-pressing. Encaustic tiles, which were made by dust-pressing, are unique in that their designs are literally "inlaid" into the tile body, rather than surface-applied. Once formed, tiles are dried slowly and evenly to avoid warpage, then fired in a special kiln that controls high, even heat at temperatures up to 1200°C (or approximately 2500°F) for 30-40 hours. Higher temperatures produce denser tiles with harder glazes. Most ceramic tiles require only one firing to achieve low porosity and become vitrified or glass-like, but some, especially highly decorated tiles, are fired more than once. Non-vitreous and semi-vitreous tiles are fired at lower temperatures and are much more porous.

Historical Background [return to top ▲](#)

Historically, the use of ceramic floor tiles goes back to the fourth millennium B.C. in the Near and Far East. The Romans introduced tile-making in Western Europe as they occupied territories. However, that art was eventually forgotten in Europe for centuries until the 12th century when Cistercian monks developed a method of making encaustic floor tiles with inlaid patterns for cathedral and church floors. But, this skill was again lost in the 16th century following the Reformation. Except for finely decorated wall tiles made in Turkey and the Middle East, and Delft tiles made in Holland in the 17th century, ceramic floor tiles were not made again in Europe until almost the mid-19th century.



In the 19th century, Minton tiles were sold from this catalogue to American clients. Photo: NPS files.

The modern tile industry was advanced by Herbert Minton in 1843 when he revived the lost art of encaustic tile-making in England. The industry was further revolutionized in the 1840s by the "dust-pressing" method which consisted of compressing nearly dry clay between two metal dies. Dust-pressing replaced tile-making by hand with wet clay, and facilitated mechanization of the tile-making industry.

Throughout the rest of the 19th century, dust-pressing enabled faster and cheaper production of better quality floor tiles in a greater range of colors and designs. In the 1850s encaustic tiles were selected for such important structures as the new Palace at Westminster in London, and Queen Victoria's Royal Residence on the Isle of Wight. By the latter part of the 19th century, despite the fact that encaustic tiles were still quite expensive, they had become a common flooring material in many kinds of buildings.

Development of the Tile Industry in America

Although plain, undecorated ceramic tiles were traditionally a common flooring material in many parts of the Americas, especially in Latin and South America, ceramic floor and roof tiles were probably not made in the North American Colonies until the late-16th or early-17th century. It was, however, in the Victorian era that ceramic tile flooring first became so prevalent in the United States. The production of decorative tiles in America began about 1870 and flourished until about 1930.

Like so many architectural fashions of the day, the popularity of ceramic tile floors in America was greatly influenced by the noted architect and critic, Andrew Jackson Downing. In his book *The Architecture of Country Houses*, published in 1850, Downing recommended encaustic floor tiles for residential use because of their practicality, especially in vestibules and entrance halls.

The 1876 Philadelphia Centennial Exposition, with its European and even a few American exhibits of decorative floor tile, was a major factor in popularizing ceramic tile floors in the U.S. Initially, most ceramic tiles-other than purely utilitarian floor tiles-were imported from England, and their relatively high cost meant that only wealthy Americans could afford them. However, when English tile companies realized the potential for profitable export, they soon established agents in major U.S. cities to handle their American business. The English near monopoly actually stimulated the growth of the U.S. tile industry in the 1870s resulting in sharply decreased English imports by 1890.

The location of potteries and ceramic tile factories is dependent upon the ready availability of suitable ball clay (clay that balled or held together), kaolin (a white clay used as a filler or extender), and feldspar (a crystalline mineral), and an accessible market. Since the cost of shipping the manufactured products tended to restrict profitable sales to limited areas, this usually determined whether a factory would succeed. Although the United States Pottery in Bennington, Vermont, is known to have made encaustic tiles as early as 1853, the Pittsburgh Encaustic Tile Company (later the Star Encaustic Tiling Company), was the first successful American tile company, and is generally considered the first to manufacture ceramic tile in the U.S. on a commercial basis beginning in 1876.

At least 25 ceramic tile companies were founded in the United States between 1876 and 1894. In the East, several notable tile firms that were established in this period flourished in the Boston area, such as the Chelsea Ceramic Art Works, the Low Art Tile Works, and the Grueby Faience Company. Other East Coast companies organized in the late-19th and early-20th century included the International Tile & Trim Company, in Brooklyn, New York; the Trent Tile Company, Providential Tile Company, Mueller Mosaic Tile Company, and the Maywood Tile Company, all in New Jersey; and the Moravian Pottery and Tile Works in Doylestown, Pennsylvania.

Many factories were also established in the Midwest—in Indiana, Michigan, and, especially, in Ohio. In the last quarter of the 19th century, the town of Zanesville, Ohio, was the largest center for pottery and tile-making in the world. Some of the factories in Zanesville included: Ohio Encaustic Tile Company; Mosaic Tile Company; Zanesville Majolica Company; and J.B. Owens Pottery, later to become the Empire Floor and Wall Tile Company. The American Encaustic Tiling Company, established in 1876, was one of the first, and most successful manufacturers in Zanesville. In the early 1930s it was the largest tile company in the world, producing large quantities of floor tile, plain and ornamental wall tile, and art tile until it closed about 1935, as a result of the Depression. The United States Encaustic Tile Company, Indianapolis, Indiana; Rookwood Pottery, Cincinnati, Ohio; Cambridge Art Tile Works, Covington, Kentucky; and Pewabic Pottery, Detroit, Michigan, were some of the other well-known potteries in the Midwest.

Around the turn of the century, the industry began to expand as tilemakers moved West and established potteries there. Joseph Kirkham started the ceramic tile industry on the West Coast in 1900 when he set up the Pacific Art Tile Company in Tropic, California, after his company in Ohio was destroyed by fire. In 1904 the company became the Western Art Tile Company, surviving for five years until it went out of business in 1909. During the early-20th century, other companies were founded in Southern California, in and around Los Angeles. Batchelder & Brown, in particular, of Pasadena (later Batchelder-Wilson in Los Angeles), was well-known for its Arts and Crafts-style tiles in the teens and 1920s. By the early 1940s California had become one of the leading producers of tile, especially faience, in the U.S.

Ceramic engineers, potters and artists not only moved frequently from one pottery to another, but often struck out on their own and established new factories when dissatisfied with a former employer. Also, it was not uncommon for one company to reuse a defunct factory or purchase another pottery business, change the name and increase the product line. As a result, many of the companies in existence today are descendants of the early pioneering firms.

Changes in the Tile Industry

The majority of ceramic floor tile made in the U.S. before 1890 was encaustic, but various factories gradually began to develop and produce other kinds of tiles. The Trent Tile Company, among others, started to manufacture both white and colored ceramic mosaic tiles by the mid-1890s. White vitreous wall tile became available, as well as more decorative tiles with colored glazes, such as the variegated faience glazes intended to give a more hand-crafted appearance that were originated by the Grueby Faience and Tile Company in 1894, and soon adopted by other potteries.

In the 19th and early-20th century, many ceramic tile firms had their own engraving departments, while some used commercial designs supplied by professional printers. Well-known designers were often commissioned to work on specific product lines for a particular firm. These

designers worked for one firm after another which resulted in similar designs being produced by different companies. (Historic ceramic floor tiles were usually identified by a manufacturer's or designer's mark on the back, if they were marked at all.) By the latter part of the 19th century ready-mixed glazes and colors were also available.

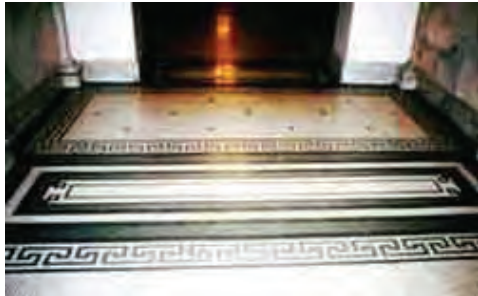

Ceramic mosaic tiles are a practical floor covering in the entryway of this early 20th century school building. Photo: NPS files.

This was a great advantage for potters who, prior to this, had to mix their own colors and glazes.

During the 20th century, the floor tile industry continued to evolve as much as it had in the previous century. Modern methods of production employed sophisticated machinery, new materials and decorating techniques. In the years following World War II, there were many advances in the industry. Commercially manufactured dust-pressed tiles, which had previously required more than 70 hours just in the kiln, could be made in less than two hours from the raw material stage to finished tiles, boxed and ready to ship. Dried, unglazed tiles were sprayed with colored glaze evenly and automatically as conveyors carried the tiles into the tunnel kilns, and the extrusion process ensured that the tiles were cut to a uniform thickness and size. The changes and developments in the production of floor tile brought forth a wide range of shapes and sizes, along with new colors, glazes and decorating techniques.

After the turn of the century, fewer encaustic floor tiles were used, particularly in residential architecture. The introduction of ceramic mosaic floor tiles was a factor in their decline. The development of rubber interlocking floor tiles in 1894, along with other, more resilient, flooring materials, was instrumental in the decreased popularity not only of encaustic tiles, but also other ceramic tile flooring. These new materials were not only cheaper, they were not as fragile; they were also lighter and thinner, and easier to install.

Ceramic mosaic tiles remained in common use through the 1930s in part because an innovative development had made laying such small tiles easier. The tiles were pre-mounted in decorative patterns on 12" x 12" sheets of paper, and sold ready to lay in cement. This greatly simplified the tile setter's work, and no doubt was a significant factor in the increased popularity of ceramic mosaic tiles. Sophisticated mosaic floor designs became common in entrance foyers of public and

private buildings. Small, white, unglazed tiles in round, square, octagonal or hexagonal shapes were promoted for their sanitary qualities, particularly for bathroom floors, while larger, rectangular, white, glazed tiles were used for bathroom walls or wainscoting. Colored tiles were also popular, especially for bathrooms, and even kitchens. Quarry tile, which was larger and thicker than other ceramic floor tile of this period, was often used in public buildings, as well as for entrance halls, small studies, libraries, dining rooms and even living rooms in private homes. But, by the 1930s, the fashion for art tile had diminished to the point where floor tiles were, for the most part, generally regarded as primarily utilitarian, as opposed to important decorative elements.

Ceramic Floor Tile Types [return to top ▲](#)

The **thickness** of historic ceramic floor tiles varied considerably according to their intended use and when they were made. Floor tiles were thicker and harder than wall or ceiling tiles. Stove tiles, meant to retain the heat of the stove, were sometimes as much as several inches thick. Medieval floor tiles were usually one inch thick; encaustic tiles of the Victorian era tended to be slightly thinner. Modern, 20th-century tiles, with the exception of some art pottery tiles, are the thinnest, as a result of modern manufacturing methods. The backs of most, but not all, ceramic floor tiles are covered with raised (or sometimes recessed) ridges, circles or squares which help to increase the bonding capability of the tile.

Unglazed and Glazed Tiles

Ceramic floor tiles can generally be divided into two types: **unglazed** and **glazed**. Unglazed tiles include: quarry tiles; encaustic and geometric tiles; and ceramic mosaic tiles, which can be either glazed or unglazed. Most other ceramic floor tiles are glazed.

Unglazed Tiles

Quarry tiles are the most basic type of historic ceramic floor tile. Originally made from quarried stone, they are machine-made using the extrusion process. Quarry tiles are unglazed, semi-vitreous or vitreous, and essentially are square or rectangular slabs of clay baked in a kiln. The colors of quarry tiles are natural earthen shades of gray, red and brown determined by the clay and, to some extent, the temperature and duration of firing. Quarry tiles, which range from ¼" to ½" in thickness, are available in square and rectangular shapes in sizes that include 3", 4-1/4", 6" (one of the most common sizes), 9" and 12" squares; 6" x 12", 6" x 9", 4-1/4" x 9", 3" x 6", and 3" x 9" rectangles; and 4" x 8" hexagon shapes. (Pavers or paver tiles are a simpler, and tend to be somewhat cruder, version of quarry tiles. Like quarry tiles, they are usually unglazed, but slightly thicker. Machine-made pavers are either semi-vitreous or vitreous, and

generally formed by dust-pressing, although sometimes are extruded. Hand-made pavers which are common in Mexico and southern Europe are non-vitreous.)

Encaustic tiles are a type of traditional unglazed-yet decorative-floor tile, manufactured by the dust-pressed method.



Encaustic floor tiles were decorated with traditional as well as original designs. Over time, the decorations can be worn thin by heavy traffic. Photo: NPS files.

Whereas most ceramic tiles are surface-decorated or decorated with impressed or embossed designs created by a mold, encaustic tiles are unique in that their decorative designs are not on the surface, but are inlaid patterns created as part of the manufacturing process. First, a thin, approximately ¼" layer of fine, almost powder-dry, clay was pressed into a mold with a relief design at the bottom which formed a depression in the face of the tile. A second, thicker layer of coarser clay was laid over the first layer, then covered with another layer of fine clay. This "sandwich" helped prevent warping and ensured that the body of the tile was strong and had a fine, smooth surface. The layers of clay "dust" were compacted by presses, after which the mold was inverted and the die removed, thus producing a tile with an indented or intaglio pattern on top. After the tile dried, colored slip (liquid white clay colored with dyes), was poured to fill in the intaglio pattern. Each color had to dry before another color of slip was added. The recessed area was overfilled to allow for shrinkage, and after drying for several days, and before firing, the excess slip was scraped off the surface by a rotating cutter that created a flat, although not completely smooth, face. Problems might arise during the firing. Due to the dissimilar rates of contraction of the different clays, the inlaid clay could shrink too much and fall out of the tile recesses; or, the tile could be stained by the different pigments used for the design if impure or unstable.

By the 1840s, encaustic tiles were made entirely with almost-dry clay using the dust-pressed method. This served to eliminate the possibility of staining the body of the tile with other colors and permitted the use of more colors on a single tile. Thus, an encaustic tile can sometimes be dated according to the complexity and the number of colors in its pattern. Red tiles with white figurative patterns were generally the earliest, followed by brown and buff colored tiles. In the

1860s, blue tiles with yellow or buff patterns were popular, succeeded by more subtle color schemes featuring a "chocolate" red with a soft grey. By 1860, up to six colors were used in a single tile to form a pattern. Toward the end of the century, white encaustic tiles with a black or gold design were common, as well as tiles with complicated color patterns of white, black, gold, pink, green and blue. Encaustic tiles were decorated with traditional as well as original designs. Some, particularly intricate, designs were painted on the surface of the tile with opaque colored glazes, instead of being inlaid. Most major tile manufacturers sold many of the same pre-formed encaustic floor tile patterns through catalogues. Encaustic tiles were produced in a variety of sizes, mostly square or octagonal in shape, and almost any design could be custom-made for a special purpose or to fit a particular space. Historic, 19th-century encaustic tiles were generally slightly less than 1" thick, about 15/16." Cheaper tiles of lesser quality were also made of clay or cement. These designs resembled those commonly found on encaustic tiles but applied as a transfer printed pattern, or using a multi-color lithographic or silkscreen process. These are still manufactured and popular in many parts of the world.

Smaller, single-colored versions of encaustic tiles that, when assembled together form a geometric pattern, are called **geometric tiles** in England. However, in the United States they are generally not differentiated from encaustic tiles. Based on the geometric segments of a six-inch square, they were typically rectangular, square, triangular or hexagonal in shape, and about the same thickness as patterned encaustic tiles. Geometric tiles were especially well suited for decorative borders, and a wide variety of floor designs could be created with their many shapes, sizes and colors—either alone or combined with patterned encaustic tiles. The cost of producing geometric tiles was much less than of encaustic tiles because each tile involved only one type of clay and one color. By the end of the 19th century, over 60 different shapes and sizes of geometric tiles were available in up to ten colors, including buff, beige or tan, salmon, light grey, dark grey, red, chocolate, blue, white and black.



Ceramic mosaic tiles were practical for structures like this Bath House, Hot Springs, Arkansas (1914-1915). Photo: Jack E. Boucher, HABS Collection, NPS.

Ceramic mosaic tiles are essentially smaller versions of geometric tiles (usually no larger than 2-1/4", and no thicker than 1/4") ranging in size from 1/2" to 2 3/16", in square, rectangular or oblong, hexagonal, pentagonal and trapezoidal shapes. Both vitreous and semi-vitreous mosaic tiles were available, unglazed in solid or variegated colors with a matte finish, or glazed in unlimited colors. Single, one-piece tiles were also fabricated to give the appearance of multiple mosaic pieces. This was achieved with a mold, which gave the appearance of recessed mortar joints separating individual "mosaics".

Glazed Tiles

With the exception of quarry tiles, encaustic tiles, and some mosaic tiles, most ceramic floor tiles are decorated with a glaze. While unglazed tiles derive their color solely from the clay, or from oxides, dyes or pigments added to the clay, the color of glazed tiles is provided by the glaze, either shiny or matte. Some potteries specialized in certain kinds of glazes and were famous for them. The earliest and most common method of clay tile decoration made use of tin-glazes which were essentially transparent lead glazes. Tiles were either dipped into the glaze or the glaze was brushed on the tile surface. Glazes were generally made with white lead, flint, or china clays ground up and mixed with finely ground metallic oxides that provided the color. Colored glazes were commonly known as "enamels". Colors included blue derived from cobalt, green from copper, purple from manganese, yellow from antimony and lead, and reds and browns from iron. An opaque glaze was created by adding tin oxide.

Laying Historic Ceramic Tile Floors

[return to top ▲](#)

19th Century Techniques

Aside from the use of improved tools and modern materials, installation methods have changed little since the mid-19th century. M. Digby Wyatt, an architect for one of the major 19th century encaustic tile manufacturers in Britain, Maw & Co., described this procedure for laying encaustic and geometric tiles in 1857:

First, either an even layer of bricks, a 2-1/2" bed of concrete of quicklime and gravel, or a mixture of Portland cement and clean sharp sand was laid to prepare a solid foundation for the tiles. If the tiles were to be laid over an existing wooden floor, the floor boards had to be pulled up, sawn into short lengths and fitted between the joists. Concrete filled in the spaces and made the base flush with the upper face of the joists, and created a level surface finished within 1" of the finished floor line. A layer of cement mortar was then laid on top. This allowed the tiles to fit in the same amount of space as the floorboards they replaced.*Before laying the tiles, skirting

boards or shoe moldings were to be removed, and replaced after the tiles were laid. This eliminated having to cut the outer tiles to fit exactly, and resulted in a neater appearance.

Next, the floor design was marked off with mason's string or chalk lines which divided the space into equal quadrants. The first section to be laid out was defined by two parallel strips of wood, or guide pieces, about 4" wide. A level thickness of cement was spread between these strips. The tiles, thoroughly soaked in water, were laid in the cement and leveled with a straight-edge. The foundation had to be kept wet while the tiles were being laid. Small strips of wood temporarily placed at right angles to the guide pieces helped keep elaborate patterns straight.

When the bed was hard, the joints were filled with pure cement mortar-sometimes colored with lamp black, red ochre or other natural pigments-mixed to the consistency of cream. Excess mortar was wiped off the tiles with a piece of flannel or sponge.

A newly-laid tile floor could not be walked on for 4-6 days until the cement hardened properly. Occasional washing would remove the saline scum that often appeared on the surface right after the tiles were laid.

20th Century Techniques

Almost 50 years later, in 1904, the Tile Manufacturers of the United States of America published *Suggestions for Setting Tile* with the intent of bringing tile-laying up to a uniform standard. This guidance was very similar to that given by Wyatt. But, there were some differences, such as using hollow clay tile as a foundation material and heavy tar paper when laying tile over a wooden floor to protect the floor boards from the moisture of the mortar mix. Emphasis was placed on using the best quality cement, sand, and purest water to obtain a durable tile floor. Soaking the tiles before setting was no longer necessary, but using stiffer mortar was suggested to prevent it from rising up between the tiles.

Tile-laying methods changed somewhat more later in the 20th century, mostly due to the availability of new materials and techniques. By the 1920s small ceramic mosaic tiles were manufactured as 12" square sheets held together by a face-mounted paper "skin." This made it possible to lay the 12" square of tiles as a unit rather than each of the small tiles individually. Mounting the tiles directly in the cement resulted in a very strong bond. But the face-mounted paper obscured the tiles from view making it difficult for the tile-setter to see if the tiles were being laid straight. The fact that the paper was not removed until after the tiles were firmly set in the cement bond coat further complicated realignment of crooked tiles. This paper "skin" was eventually replaced with a fabric mesh backing. This permitted the tiles to be aligned as soon as the moisture from the bond coat loosened the mesh from the back of the tile; it also allowed a single tile to be cut away from the mesh and repositioned immediately. Although the fabric mesh

made tile setting faster, sometimes it also resulted in a weaker bond by reducing the contact area between the backs of the tiles and the bond coat.

Following World War II, different methods of preparing a foundation for a ceramic tile floor were developed to be more compatible with new materials, such as reinforced concrete, expanded wire mesh, polyethylene and waterproof plywood. New adhesives and grouts also facilitated tile installation, and an increased variety of epoxy and cement mortars allowed for different setting bed thicknesses. But today, after half a century of practical application, some of these "new" materials, such as plywood, particle board, oriented strand boards and other wood panels, are no longer recommended for use with ceramic tile.

Mortar beds are lighter, more flexible, and much thinner than they were previously, having shrunk from several inches to as thin as 3/32". A greater variety of materials are used for setting ceramic floor tiles, including bonding agents and waterproof membranes. Basic installation methods have not changed significantly, but they vary according to the type of subfloor on which the tile is to be laid. While the same concerns for level underlayment and strong adhesion exist, advancement has occurred mostly in the increased speed and ease of laying the tiles.

**The traditional practice of sawing the original floor boards and fitting them between the joists, still used today to maintain a low finished floor profile, has resulted in numerous cracked tiles and other failures. Instead, a better approach is to leave the existing floor boards, if they are in good shape, and install a cementitious backer board (CBU) available in thicknesses ranging from 1/4" to 5/8" as the setting bed for the tiles.*

Historic Ceramic Floor Tile: Preservation and Maintenance [return](#) [to top ▲](#)

Before undertaking any work more complicated than regular maintenance or a very simple repair on a significant historic ceramic tile floor, or on any historic tile floor where serious damage has occurred, it is recommended that a professional conservator of ceramics, an historical architect, an architectural historian, or a chemist with particular knowledge and experience in this field be consulted. This will ensure that all future work, whether it be regularly-scheduled maintenance or more technical and specialized repair and restoration, is done in accordance with *The Secretary of the Interior's Standards for the Treatment of Historic Properties*.



This tiled Presidential seal was laid in the floor of the Pension Building in 1901 at President McKinley's 2nd inauguration. Photo: NPS files.

Cleaning Methods

Ceramic tiles are essentially a practical, low-maintenance flooring material. Yet, even glazed tiles are somewhat porous, and can get dirty and stained, especially in heavy traffic areas or where oil, fat, and grass stains are likely to occur. Although heavily soiled areas may be difficult or impossible to clean completely, in most instances, cleaning ceramic tile floors is relatively easy. Cleaning should always begin with the gentlest means possible, which may be as simple as warm water. Regular maintenance should include sweeping, or preferably dry or damp mopping or vacuuming to reduce grit. Tiles can usually be cleaned with a non-soap-based household floor cleaner, such as one of the commercial products intended for cleaning ceramic tile floors available on the market.

All cleaning and stain-removal products should always be tested on a small, inconspicuous area before using. Abrasive cleaners (including powdered cleansers and even "mildly" abrasive creams) and mechanical equipment can damage and wear away the protective surface, as well as the decorative design on the tiles, and should not be used on ceramic tile floors. Generally, acid-based cleaning solutions should also not be used on ceramic tile floors because they can damage the complex silicates in a glaze. However, there are some acid-based cleaners specially formulated for cleaning and removing coatings from ceramic tile floors that may be acceptable, but even these must be used with caution. Sometimes an acid-based cleaner may, in fact, be needed to remove discoloration or staining caused by lime or cement mortar. But, it should be tested first, used with caution, and applied only to a thoroughly wetted tile floor from which excess water has been removed. Pre-wetting a ceramic tile floor before cleaning is a good policy to observe with all cleaners. The water saturates the porous tile and prevents chemicals or other cleaning agents from penetrating into the tile body. Floor tiles should be always rinsed thoroughly after cleaning.

Plastic pot-scrubbers may be effective in loosening and removing superficial dirt without abrading the glazed or vitrified surface of the tiles. Stubborn asphalt or oil stains, scuff marks, or soiling

can sometimes be removed with ammonia or one of the household spray products intended for cleaning kitchen or bathroom tiles. If necessary, a solvent may be applied carefully to pre-wetted tiles, but it should not be left on the surface for an extended amount of time as it may cause discoloration. If possible, a stain should always be identified first in order to select the material best-suited to remove it.

Organic growth, such as mold or mildew, can be eliminated with a dilute solution of household bleach and a neutral household detergent, or a dilute (5-10%) solution of tri-sodium phosphate (TSP). After applying either of these solutions, it may be necessary to scrub the floor with a natural bristle or nylon brush, and then rinse with clear water. Even a dilute bleach solution should not be left on a ceramic tile floor for more than a few minutes, since the alkali in the bleach can lead to the formation of a white efflorescent deposit. Efflorescence (a whitish haze of water-soluble salts) may stain and streak the tile, or may even cause minor spalling around the joints.

Regular maintenance of a ceramic tile floor should always begin with vacuuming to remove loose dirt and grit. Then, a mild cleaning solution may be applied and left on the floor for 10-15 minutes, without letting it dry on the tiles. Heavily soiled areas may be scrubbed with a natural bristle or nylon brush to loosen dirt from the tile surface. Finally, the floor should be thoroughly rinsed with clean, clear water, preferably twice, and dried with terry cloth towels, if necessary. Any proprietary cleaning product should always be used in accordance with the manufacturer's directions.

Protective Coatings

In most instances, traditional ceramic tile floors probably would not have been treated or given a protective coating other than wax. In the 19th century, some encaustic tile floors were treated with linseed oil, but this is not a practice recommended today because linseed oil tends to attract dirt and discolors as it ages. Most historic ceramic tile floors simply acquired a natural "polish" or sheen through use. Because the surface of ceramic tiles is already protected with a fired skin or a glaze, an additional protective coating should generally not be needed.

Opinions differ concerning the use of protective coatings, penetrating sealers, or waxes on ceramic tile floors, and, especially, on historic ceramic tile floors. If properly applied and regularly cleaned, a coating can sometimes be an effective maintenance treatment, but only on interior floors. However, if not adequately or properly maintained, rather than facilitating maintenance of ceramic tile floors in high traffic areas, such coatings may tend to emphasize traffic patterns as they wear away or become scratched. Some coatings may also peel in spots, or cause tile to appear hazy or cloudy if the coating is not applied in accordance with the manufacturer's specifications, or if the tiles are not perfectly clean when the coating is applied. Furthermore, applying such a coating may actually increase maintenance costs, since a coating

requires periodic removal and renewal. The frequent removal of a coating can also damage a ceramic tile floor if it is carried out with harsh chemicals or abrasive mechanical equipment. If any coating is considered, a traditional coating, such as floor wax, may be the most suitable. Wax is easy to remove when it becomes worn, and does not impart a high, potentially inappropriate, gloss to the surface.

On the other hand, a penetrating sealer, or *impregnator*, may be worth considering to protect patterned encaustic tiles, or painted or printed tiles featuring a design that might be worn off, particularly in public buildings with a high volume of foot traffic. For example, some manufacturers of new, reproduction encaustic tiles recommend applying a penetrating sealer to the replacement tiles, as well as to the historic tiles. Impregnators do not change the color of the tile surface and, unlike some penetrating sealers, are completely invisible after they have been applied. They can reduce the porosity or water absorption of the tile surface, and provide some protection for the tile (and the grout) against staining. This may be particularly useful on light-colored floors. Whether to apply an impregnator to an historic ceramic tile floor, and what type or product to use, are decisions that should generally be made in consultation with a conservator or ceramic tile specialist. *It may also be necessary to comply with certain safety standards and friction requirements of the ADA (Americans with Disabilities Act). The ADA Guidelines recommend "a static coefficient of friction" of 0.6 for level surfaces and 0.8 for ramps. This may require the application of a non-slip sealer or wax to historic ceramic tile floors in some public buildings.*

Despite the non-traditional shiny finish they may impart to a floor surface, two-part, acrylic-based coating systems are commonly used today on historic ceramic tile floors in many public buildings, primarily because they facilitate easy maintenance. If it is decided that a sealer is to be used, a product with a matte or dull finish may be preferable, or more appropriate, for a historic ceramic tile floor than one with a high-gloss.

In some cases, temporary protection may be the best approach until a better solution is found. Non-permanent protection for an historic ceramic tile floor may be as simple as using floor mats at doors or in heavy traffic areas.

Historic Ceramic Floor Tile: Damage and Deterioration Problems [return to top ▲](#)



Worn encaustic tiles are still serviceable, but once the design has been lost, the tiles cannot be repaired. They must be replaced in kind, to match. Photo: NPS files.

Loss of Tile Surface and Pattern

Ceramic tiles are among the most durable of historic flooring materials, but natural wear and a certain amount of deterioration or damage is inevitable. Some tiles, such as dense, close-textured quarry tiles and ceramic mosaic tiles, resist abrasion and stain absorption very well. But many others, especially patterned encaustic and geometric tiles, are extremely susceptible to abrasion. Heavy traffic can also result in uneven wear, or even cupping, in certain areas of tile floors that get more use than others, such as doorway entrances. The particular clay mix, or the dye or pigment used to color the clay, can also affect the hardness and durability of individual tiles or an entire ceramic tile floor.

Tile Glaze Failure

Occasionally some glazes can become pitted or powdery as they age. Lead glazes used in the 19th century, which were fired at low temperatures, deteriorated relatively quickly. Glazes have different physical properties from the fired clay tile body itself, and as a result may sometimes crack or craze. Unless the crazing visibly extends into the porous clay of the tile body beneath, this is not generally a serious material failure; however, dirt entering these cracks cannot be removed, and will discolor the tile. If the crazing penetrates through the glaze, it may increase the water absorption of the tile.

Tile Breakage

Ceramic floor tiles are very susceptible to damage and breakage caused when something heavy is dropped. Repeated passage of heavy objects, or carts, over a floor can also crack and break ceramic tiles, as well as heavy vibration from outside traffic.

Moisture Damage to Tile

Ceramic tile floors have been traditionally viewed as highly waterproof systems that do not require protection from moisture. In reality, however, this is not true. Water-related problems are one of the most common causes for the deterioration and failure of historic tile floors, particularly in bathrooms and other rooms where there is a lot of moisture. Water that is allowed to sit in areas around shower stalls and bathtubs can eventually damage grout and mortar, and loosen tiles. Some of the more porous kinds of tiles that are not as hard-fired may actually begin to powder or spall if subjected to constant moisture.

Loose, Cracked, Broken or Unbonded Tile Due to Mortar Failure

The durability of ceramic tile floors depends to a great extent on a sound mortar bed and sound mortar joints. The wrong mortar type or mortar that is inadequately mixed can also spell trouble for a ceramic tile floor. Failure of a tile floor system laid over a subfloor is often the result of weakened or deteriorated grout or mortar which allows the tiles to become loose. Mortar may also be weakened or loosened by cleaning solutions that are too strong.

Proper tile-laying technique includes the use of a material that will allow for some movement of the tiles. Traditionally, a layer of asphalt (replaced by a layer of plastic or building paper in more modern construction) was inserted to separate the base and the bedding underneath. This prevents bonding between the base and the bed, and allows for some "relative" movement. It is intended to prevent the ceramic tile floor from arching or ridging, a condition in which single or entire rows of tiles can pop up to relieve tension and separate completely from the bed. When this happens, the condition will probably require taking up and relaying many or all of the tiles.

Tile Damage or Loss Caused by Systems Update

The installation of new plumbing, electrical and HVAC systems, or the attachment of new fixtures and furnishings, may be one of the most common sources of damage to an historic ceramic tile floor. Earlier remodeling projects to remove old pipes or to replace "out-dated" bathroom fixtures may have resulted in the loss of floor tiles. Different shapes and sizes of new fixtures, equipment or pipes may have exposed previously untiled areas that have been inappropriately patched with cement. Careless workers and insensitive installations can also result in damage, breakage or removal of historic floor tiles. All of these conditions will require matching replacement tile.

Historic Ceramic Floor Tile: Repair and Replacement [return to top ▲](#)

The Secretary of the Interior's Standards for the Treatment of Historic Properties emphasize the retention and preservation of historic building material. Preservation and repair treatments are always preferable to replacement.

Mortar Joint Repair

Deteriorated mortar joints and loose mortar or grout can generally be repaired. First, the entire floor should be checked for loose tiles that need to be regouted. Damaged mortar should be carefully removed by hand and the joints wetted or a bonding agent applied in preparation for regrouting. When making mortar repairs, it is important to use grout that matches the old in color and consistency as closely as possible.

Tile Repair

Trying to remove one tile can endanger surrounding tiles. Thus, it may be better to preserve and retain an original historic tile that is only slightly damaged, rather than replace it. Sometimes cracks may be repaired, or a corner or piece of tile that has broken off may be re-attached, using an epoxy glue, or grout. If a tile is chipped or a small corner or edge is missing, a carefully executed patch of epoxy-mixed with colored enamel, or mortar tinted to blend with the tile, may be less conspicuous than trying to replace every tile that has even the slightest damage. And, it is a better preservation treatment.

In limited instances, glaze failure or surface powdering of ceramic floor tiles may sometimes be treated successfully by a conservator with a specially formulated, solvent-based, mineral densifying agent (such as silicic acid), followed by a siloxane sub-surface repellent, applied 24 hours later. Under the right circumstances, such a treatment can harden and bind the surface, and lower the absorbency of the tile, and still maintain the vapor transmission. But this is a highly complex undertaking and should only be attempted by a conservator after appropriate testing. Not only are these chemicals highly toxic and dangerous to handle, but if used improperly, they can cause greater damage to the tile!



This inappropriate ceramic tile repair is easy to spot. Photo: NPS files.

Tile Replacement

When an individual tile or a larger portion of an historic ceramic tile floor is missing or so severely damaged that it cannot be repaired, or if it has become a safety hazard, then it should be replaced. When a ceramic tile floor has deteriorated as a result of long term wear and abrasion, or from settlement or vibration damage to the setting bed, there are a number of factors that need to be considered before choosing a preservation treatment. If damage to tiles is the result of more than normal wear and tear, the source of the problem needs to be identified, and the problem corrected before replacing the damaged tiles.

Successful replacement not only depends on the availability of matching tiles, but on the condition of the substrate on which the tiles are laid. Before installing the replacement tiles, any problems, such as settlement or vibration, will have to be addressed, and the height of the new setting bed may have to be adjusted for the thickness of the new tiles.

Selective Replacement of Individual Tiles

This cautious approach, typically an attempt to replace only the most seriously damaged tiles, is often taken or considered when only a small number of tiles are involved. Unless old, matching tiles can be found and reused, replacement often requires specially fabricated reproduction tiles. In some instances, individual historic tiles that are damaged may be replaced with matching tiles salvaged from other, less prominent areas of the floor or from other buildings. This is most feasible if the tiles to be replaced are either plain, and easy to match, or decorated with a common historic floor tile pattern.

In order to replace damaged tiles, it can be helpful to identify the manufacturer and the approximate date of the tiles, if possible. However, many mass-produced tiles are not marked and give little or no information as to their origin, although stylistic similarities with other marked tiles may sometimes provide a clue as to the manufacturer. Some decorating firms seldom signed their work, while many firms made bisque tiles (plain, unglazed, once-fired tiles) for other companies, as well as their own use. Identifying marks will generally be found on the back of the tile. A mark impressed or molded into the back of the tile may give the name or initials of the company which made the tile or the bisque; sometimes a printed or painted mark indicates if it was decorated by a different company, or artist. Historic building records and construction documents may provide information about the tile company or supplier. Catalogues of the period may also be useful in identifying the tile manufacturer of unmarked tiles.

Replacing a single damaged tile is based on the ability to remove only the deteriorated tile without harming surrounding tiles. Attempts to remove one or several damaged tiles often fail because a hammer and chisel are used. The shock of the blows to the tile being removed travels through the grout into surrounding tiles and cracks them. To avoid damaging good tiles, all the grout around the tile must be removed. This is best accomplished by an experienced tile installer using a hand tool called a grout saw or, for grout joints wider than 3/8", a dry-cutting diamond blade, mounted in an angle grinder or circular saw.

Other difficulties may be encountered when selectively replacing damaged tiles with reproduction tiles. New tiles, especially encaustic tiles, may be different in thickness and, sometimes, despite the attention to detail of the reproduction process, slightly different in color and design from historic tiles. This can cause both visual and physical problems, especially if the replacements are being laid in a piecemeal fashion.

If the setting bed does not have enough mortar to grip and hold the tile, one new tile laid among the originals will eventually come loose. If the new and old tiles are different thicknesses, the setting bed in which the new tiles are laid must be at a different height to create a level finished surface. In addition, the two levels of setting beds may be of different composition; one may be harder, stronger and less flexible than the other. This may also lead to problems, since the setting bed foundation should act and respond as a unit to the load and stresses placed upon it.

Sectional Replacement of Tiles

In some instances, the best approach may be to remove a complete section of damaged original tiles and replace that section of floor in its entirety with new reproduction tiles. Advantages of this method include the ability to lay a level setting bed, as well as achieving a finished product that is uniform in color and pattern match. Although this approach may involve replacing more original tiles with reproduction tiles than may be absolutely necessary, original tiles that remain in good condition can be saved to be reused in other sections where only a few tiles are

damaged. This technique is generally most appropriate either when the section being replaced is the most damaged portion of the floor, or is in a relatively inconspicuous location and the tiles that are removed will supply enough salvaged pieces to permit in-kind repair of a more visually prominent area.

When laying a section of reproduction tiles, it may be a good idea to use contemporary materials and installation methods such as expansion joints or flexible expansion material. One of the major causes of ceramic floor tile installation failure and cracked, broken or disbonded tiles is the lack of expansion joints. Expansion joints were sometimes used in laying historic ceramic tile floors, and these are frequently the ones that have survived in the best condition. Many preservation contractors hesitate to use conventional expansion joint filler materials because of their limited range of colors. However, there are new flexible sealants in a wide range of colors that are available in either sanded or unsanded textures to match the surrounding grout joints. As a result, the expansion joints are almost invisible. A bonding agent may also be considered-if recommended by the tile manufacturer-and any drawings provided by the manufacturer should be used to guide the installation.

Each preservation technique has advantages and disadvantages that the historic property owner or manager should take into consideration before deciding which one is best suited to the particular flooring problem. For example, slight differences in the shape, size, color and the pattern between the old and the new tiles are frequently encountered. If replacing an entire section, the slightest difference in size and dimension between the original tiles and the reproduction tiles, even if it is as small as 1/8" or 1/16", can mean that the new section of tile will not fit inside an existing border. Even though drawings and photos are provided to the manufacturer, there may be some variation in the design and pattern size on the new tiles. Thus, they may not align perfectly with the original tiles, and as a result the section of the floor that has been replaced may be quite conspicuous.

Summary and References [return to top ▲](#)

Historic ceramic tiles are a common flooring material in many different kinds of small, as well as large, private and public, structures throughout the United States. Whether plain, or decoratively patterned, traditional ceramic floor tiles are important in defining the character of historic buildings. Although ceramic floor tiles are a practical material, they are also fragile, and can be easily damaged by improper installation techniques, insensitive remodeling, harsh cleaning methods, and even regular daily use. Preserving them requires careful day-to-day maintenance. This should begin with using gentle, non-abrasive methods and materials to clean them, and, in some instances, using an appropriate coating or impregnator to protect them.

Some historic ceramic tile floors, due to their manufacturer, their unique design, or their location in a certain room or within a particular building, may have greater significance than those that

are purely utilitarian. Such floors should be accorded special care, and a ceramics conservator or preservation specialist should always be consulted to prepare responsible maintenance plans and to provide guidance concerning repair treatments and replacement techniques for them.

Unless an historic ceramic tile floor is extensively damaged with many missing and broken tiles and, therefore, potentially hazardous, it may be preferable to leave it alone. An unevenly worn floor surface, worn colors or patterns on the tiles, or slight cracks, chips, or scratches in the tiles themselves does not necessarily mean that the tiles should be replaced. Such relatively minor imperfections seldom detract from the character of an historic ceramic tile floor. They may, in fact, impart character, and be less noticeable or obtrusive than replacement of a single tile or a larger section with new tiles that do not match the originals exactly. Each situation should be evaluated on its own basis before selecting the preservation approach best suited to the project.

Some Sources for Replacement Tiles

There are a number of companies that offer standard lines of reproduction tiles, while others focus on custom work. Some new lines of reproduction tile attempt to be exact replicas of original tiles from the late-19th and early-20th century, while others are modern interpretations or adaptations of traditional designs, and may not be appropriate as replacement tiles in a preservation or restoration project. For additional sources see: "Traditional Building's Ceramic Tile SourceList," *Traditional Building*, Vol. 9, No. 4 (July/August 1996), pp. 92-93.

- **Designs in Tile**
- P.O. Box 358
- Mt. Shasta, CA 96067
- *Custom-made reproduction art tile.*

- **Fulper Tile**
- P.O. Box 373
- Yardley, PA 19067
- *Reopened factory reproduces historic tiles using original Arts and Crafts-period glazes.*

- **HandR Johnson Tiles Ltd.**
- Head Office: Highgate Tile Works
- Tunstall, Stoke-on-Trent
- England ST6 4JX
- U.S. Office: Johnson USA Inc.
- P.O. Box 2335
- Farmingdale, NJ 07727

- *Stock and custom reproductions of Minton Hollins encaustic and geometric tiles.*
- **L'Esperance Tile Works**
 - 237 Sheridan Avenue
 - Albany, NY 12210
 - *Custom-made encaustic, geometric, mosaic and other traditional ceramic tiles.*
- **Moravian Pottery and Tile Works**
 - Swamp Road
 - Doylestown, PA 18901
 - *Reproduction tiles based on Henry Chapman Mercer's original designs.*
- **Motawi Tileworks**
 - 33 North Staebler Road, Suite 2
 - Ann Arbor, MI 48103
 - *Reproduction tiles in Arts and Crafts, Art Nouveau and other styles.*
- **Native Tile and Ceramics**
 - 4230 Glencoe Avenue
 - Marina Del Rey, CA 90292
 - *Reproduction decorative tiles in Southern California tradition of Craftsman, Mission, Art Deco and other styles.*
- **Original Style**
 - Stovax Ltd.
 - Falcon Road
 - Sowton Industrial Estate
 - Exeter, Devon
 - England EX2 7LF
 - *Reproduction ceramic tiles from 1750-1902.*
- **Pewabic Pottery, Inc.**
 - 10125 East Jefferson Avenue
 - Detroit, MI 48214
 - *Reopened factory reproduces original tile designs and glazes.*
- **Terra Designs Tileworks**
 - 241 East Blackwell Street
 - Dover, NJ 07801
 - *Mosaic tessarae experts, and reproduction of historic ceramic tiles.*

- **Tile Guild**
- 2840 East 11th Street
- Los Angeles, CA 90023
- *Reproduction of traditional Spanish, Portuguese, Dutch, Italian and English tiles.*
- **Tile Restoration Center, Inc.**
- 3511 Interlake N.
- Seattle, WA 98103
- *Reproduction of Arts and Crafts-period tiles.*

Helpful Organizations

- **The American Institute for Conservation of Historic and Artistic Works (AIC)**
- 1717 K Street, N.W., Suite 301
- Washington, DC 20006
- **Ceramic Tile Institute of America, Inc.**
- 12061 Jefferson Boulevard
- Culver City, CA 90030-6212
- **Friends of Terra Cotta, Inc.**
- 771 West End Avenue, 10E
- New York, NY 10025
- **Tile Council of America**
- P.O. Box 1787
- Clemson, SC 29633
- **Tile Heritage Foundation**
- P. O. Box 1850
- Healdsburg, CA 95448

Acknowledgements

Anne E. Grimmer is Senior Architectural Historian, Technical Preservation Services Branch, Heritage Preservation Services Program, National Park Service, Washington, D.C. **Kimberly A. Konrad** is a Preservation Planner, Boston Landmarks Commission, The Environment Department, City of Boston, MA. The authors wish to thank the following individuals for providing technical review and other assistance in the development of this publication: Marc Tartaro, AIA,

and William Allen, Office of the Architect of the Capitol, Washington, DC; Mary Catherine Bluder, Bucks County Historical Society, Doylestown, PA; Michael F. Byrne, Ceramic Tile Education Foundation, Clemson, SC; Milford Wayne Donaldson, FAIA, Los Angeles, CA; Gray LaFortune, CTC, Ceramic Tile Institute of America, Inc., Culver City, CA; Joseph Taylor, Tile Heritage Foundation, Healdsburg, CA; Susan Tunick, Friends of Terra Cotta, Inc., New York, NY; Anne Weber, Ford Forewell Mills and Gatsch, Architects, Princeton, NJ; Glenn Wharton, Wharton & Griswold Associates, Inc., Santa Barbara, CA; Charles E. Fisher, Sharon C. Park, AIA, and, especially, Kay D. Weeks, National Park Service, Washington, DC.

This publication has been prepared pursuant to the National Historic Preservation Act of 1966, as amended, which directs the Secretary of the Interior to develop and make available information concerning historic properties. Technical Preservation Services (TPS), National Park Service prepares standards, guidelines, and other educational materials on responsible historic preservation treatments for a broad public.

October 1996

Reading List [return to top ▲](#)

Austwick, Jill. *The Decorated Tile: An Illustrated History of English Tile-making and Design*. New York: Scribners, 1980.

Barnard, Julian. *Victorian Ceramic Tiles*. Greenwich, CT: New York Graphic Society Ltd., 1972.

Bruhn, Thomas P. *American Decorative Tiles, 1870-1930*. Storrs, CT: William Benton Museum of Art, 1979.

Byrne, Michael. *Setting Tile*. Newtown, CT: The Taunton Press, 1995.

Decorative Tile Designs in Full Color. Selected and arranged by Carol Belanger Grafton. New York: Dover Publications, Inc., 1992.

Fidler, John. "Protective Custody: John Fidler examines the options on caring for brick, tile or stone floors." *Traditional Homes*. (August 1989), pp. 112-115.

Furnival, William James. *Leadless Decorative Tiles, Faience and Mosaic*. Stone, Staffordshire: W.J. Furnival, 1904.

Lavenberg, George N. *Ceramic Tile Manual*. Los Angeles: Building News, 1986.

Massey, James C., and Shirley Maxwell. "Decorative Tile: Art for the Victorian and Arts and Crafts Home." *Old-House Journal*. Vol. XIX, No. 2 (March/April 1991), pp. 54-58.

Massey, James C., and Shirley Maxwell. "The Ceramic Circus." *Old-House Journal*. Vol. XXIII, No. 2 (March/April 1995), pp. 46-51.

Riley, Noel. *Tile Art: A History of Decorative Ceramic Tiles*. London: The Apple Press, 1987.

Rosenstiel, Helene Von, and Gail Caskey Winkler. *Floor Coverings for Historic Buildings: A Guide to Selecting Reproductions*. Washington, D.C.: The Preservation Press, 1988.

Taylor, Joseph A. "Ceramic Tiles in Commerce." *BR Building Renovation*. (Fall 1994), pp. 45-48.

The Secretary of the Interior's Standards for the Treatment of Historic Properties with Guidelines for Preserving, Rehabilitating, Restoring and Reconstructing Historic Buildings. Kay D. Weeks and Anne E. Grimmer. Washington, D.C.: U.S. Department of the Interior, National Park Service, Cultural Resource Stewardship and Partnerships, Heritage Preservation Services, 1995.

Tunick, Susan. *American Decorative Tiles*. Sponsored by Assopiastrelle (Association of Italian Ceramic Tile and Refractories Manufacturers), and coordinated by D. Grosser and Associates, Ltd., New York (1991).

Vandenburgh, Jayne M., IBD. "Restoring the Ohio State Senate Building: An American Tile Classic Returns." *Tile Design and Installation*. Vol. 8, No. 1 (January 1995), pp. 32-35.

Wyatt, M. Digby. *Specimens of Geometric Mosaic Manufactured by Maw and Co. of Benthall, near Broseley*. London: M. Digby Wyatt, 1857.



- [DOI](#)
- [Frequently Asked Questions](#)
- [Website Policies](#)
- [TPS Home](#)
- [Contact TPS](#)



GREENWOOD HISTORIC CEMETERY ESTABLISHED 1825



[Cemetery Services](#)

[About Greenwood](#)

[Resources](#)

You are here: [Home](#) ▶ [About Greenwood](#) ▶ [Rules and Regulations](#)

Rules and Regulations

CITY OF BIRMINGHAM GREENWOOD CEMETERY OPERATIONAL PROCEDURES, CONDITIONS AND REGULATIONS

I. DEFINITIONS:

The following words and phrases, for the purposes of these sections, have the meanings respectively ascribed to them, except in those instances where the context clearly indicates a different meaning.

- a. "Cemetery" shall mean Greenwood Cemetery.
- b. "Superintendent" shall mean the City Manager or his/her designee.
- c. "Marker" shall mean a stone or object denoting the location of a grave and which does not exceed eighteen (18) inches in height, sixteen (16) inches in width, and twenty-four (24) inches in length.
- d. "Monument" shall denote a memorial stone or object of a size in excess of that of a marker.
- e. "Permanent outside container" shall be a container which encloses a casket. The following are considered permanent outside containers: concrete boxes, concrete, copper or steel burial vaults.
- f. "Department" shall mean the Department of Public Services.
- g. "Memorial" shall mean monuments or markers.

II. CONDUCT OF PERSONS

Every person entering the cemetery shall be responsible for any damage caused by such person while within the cemetery. No person under eighteen years of age shall enter the cemetery grounds unless accompanied by an adult responsible for his/her conduct, or unless permission has been granted by the Superintendent.

No person shall:

- a. Enter the cemetery except through an established gate, and only during the hours from 8:00 A.M. to sundown.
- b. Deposit or leave rubbish and debris on any part of the cemetery grounds.
- c. Pick, mutilate, remove, or destroy any living plants or parts thereof, whether wild or domestic, on the cemetery grounds, except in the work of maintenance by City employees or its designated contractor.
- d. Break, injure, remove, or deface any monument or marker on the cemetery grounds.
- e. Bring any dog or animal into the cemetery grounds, unless in compliance with applicable leash law.
- f. Bring or discharge any firearm on the cemetery grounds, except in the conduct of military funerals.
- g. Carry intoxicants into the cemetery grounds, or consume such while in the cemetery.
- h. Advertise on cemetery grounds unless permitted by the City.
- i. Conduct her/himself in any other than a quiet and respectful manner while on the cemetery grounds.

III. TRAFFIC REGULATIONS

All traffic laws of the City of Birmingham that are applicable to the operation of vehicles in cemeteries shall be strictly observed. Every person driving a vehicle into the cemetery shall be responsible for any damage caused by such vehicle.

No person shall:

- a. Drive a vehicle within the cemetery at a speed in excess of ten (10) miles per hour.
- b. Drive or park a vehicle on other than established driveways except for the purpose of maintenance or construction.

- c. Turn a vehicle around within the cemetery except by following established driveways.
- d. Use a cemetery driveway as a public thoroughfare.

IV. MAINTENANCE AND PERPETUAL CARE

The City and/or its designated Contractor shall be responsible for the maintenance and repair of the driveways, buildings, water system, drainage and fences. The City and/or its designated Contractor shall also cut and maintain the grass areas, remove the leaves, trim and remove trees and shrubs, apply fertilizer as necessary, and in general maintain the cemetery as a place of natural beauty devoted to the burial of the dead.

The City and/or its designated Contractor shall not be responsible for any special care of any particular section, lot or burial space or for the maintenance or repair of any monument, marker or planting placed by the owner. Further, the City and/or its designated Contractor shall not contract or agree to give special care to any section, lot or burial space except as above provided. The City shall maintain the integrity of damaged historical markers, prior to January 1, 1875, through the perpetual care fund.

V. OPERATIONAL REGULATIONS

The following operational regulations shall apply to all areas within the cemetery:

- a. Corners of all lots will be marked by the City, or its designated contractor, with permanent markers set flush with the ground surface, and these shall not be disturbed.
- b. The erection of any fence, railing, wall, coping, curbing, trellis, or embankment, or the planting of any hedge, on any lot or grave is prohibited. No cutting of paths shall be permitted.
- c. The City, or its designated contractor, shall have the right to remove from any lot any objects, including trees and shrubs and flower pots that are not in keeping with the appearance of the cemetery.
- d. Ironwork, seats, vases, and planters shall be allowed on lots, providing that the same shall be kept in good repair and well painted. If not kept in good repair and painted, the Superintendent shall have power and authority to remove same from cemetery, and shall not be liable for any such removal.
- e. Planters of iron or granite for the planting of flowers will be removed from lots and put in storage if not filled by July 1st. Planters so removed will be sold for cartage and storage charges, or destroyed, if not claimed within a period of one year.
- f. No person shall plant, cut down, remove, or trim any tree, shrub, or plant within the cemetery except by permission of the Superintendent, or a person authorized by him/her to act in his/her stead in matters pertaining to the cemetery.
- g. The planting of flowers on any lot, or otherwise disturbing the sod, shall release the City or its designated contractor from all obligation to resod without extra charge therefore. The planting of spirea, rose bushes, peonies, or shrubs that grow over three feet in height, will not be permitted.
- h. As soon as flowers, floral pieces, potted plants, flags, emblems, etc., used at funerals or placed on grave at other times, become unsightly or faded, they will be removed, and no responsibility for their protection will be assumed, except for special groups upon notification to the City or its designated contractor.
- i. The Superintendent reserves the right to remove from beds, graves, vases, planters, or other containers, all flowers, potted plants, or other decorations, that are set out and then not kept properly watered, trimmed and free from weeds, and to do so as soon as they become objectionable.

VI. MONUMENTS, GRAVE MARKERS AND FOUNDATIONS MONUMENTS

Monuments will be permitted only on two adjoining side by side graves under one ownership. No more than one monument shall be erected on any lot.

The erection of all monuments shall be subject to the following conditions:

- a. Each monument shall be supported on a concrete foundation not smaller than the base of the monument it supports. Such foundation shall be constructed only by the City or its designated contractor after payment therefore has been made. Foundations will be installed April to November, weather dependent, as determined by the Superintendent. Requests received after November 1st will be held until conditions allow for installation.
- b. Designs for monuments must be submitted to the Superintendent or to a person designated by him/her to act in his/her stead, when application is made for construction of foundations. A form with the size, material and design must be submitted to the City or its designated contractor for approval and all installation fees must be paid in full prior to delivery of the memorial.
- c. No monument of artificial stone, sandstone, limestone, or soapstone will be permitted.
- d. All contractors and workers engaged in setting monuments shall be under the supervision of the Superintendent or a person designated by him/her, and they will be held responsible for any damage resulting from their negligence or carelessness. No work of setting monuments shall be started that cannot be completed by the end of the day following the start of such work.
- e. No monuments shall be allowed in the flush sections.

MARKERS

- a. Markers shall not exceed 1 ½ feet in height and shall have a minimum horizontal dimension at the base of not less than half of the height. All markers shall be in one piece, and shall be dressed on the bottom at right angles to the vertical axis. These measurements do not apply to government issue markers.
- b. Individual markers can be sod set without a concrete foundation.
- c. A form with the size, material and design must be submitted to the City or its designated contractor for approval and all installation fees must be paid in full prior to delivery of the memorial. Installation will not occur between November 1st and March 31st unless weather permits.

FLUSH MEMORIAL SECTION - F-NORTH ONLY

- a. No structures shall be placed or constructed by anyone other than employees of the City or its designated contractor in the area of Greenwood Cemetery designated as the "Flush Memorial Section".
- b. Bronze or granite markers only, set flush with the turf, will be permitted in this section. No structures which would extend above the ground level shall be permitted.
- c. A form with the size, material and design must be submitted to the City or its designated contractor for approval and all installation fees must be paid in full prior to delivery of the memorial. Installation will not occur between November 1st and March 31st unless weather permits.

FLUSH MEMORIAL SECTION – AREAS PLOTTED AFTER JANUARY 1, 2015

- a. On grave spaces in Sections B, C, D, K, L, and O, all memorials on new lots plotted after January 1, 2015, must be installed at lawn level. Memorials can be individual markers measuring 24" x 12" x 4" or 16" x 24" x 4" or companion memorials over two (2) graves measuring 48" x 12" x 4".
- b. The memorials must be made of acceptable bronze or granite material and set at lawn level.
- c. A form with the size, material and design must be submitted to the City or its designated contractor for approval and all installation fees must be paid in full prior to delivery of the memorial. Installation will not occur between November 1st and March 31st unless weather permits.

VII. FUNERALS, INTERMENTS AND DISINTERMENTS INTERMENTS

No lot or burial space shall be used for any purpose other than the interment of human remains and the erection of appropriate memorials to the dead.

No interment shall be made in Greenwood Cemetery until a proper burial permit has been issued, and until all other legally required permits have been issued by, and filed with, the proper authorities.

City personnel, or its designated contractor, will provide opening and closing of grave, initial and periodic maintenance only, and will not be responsible for handling and lowering vaults or caskets. Tents, lowering devices and other materials shall be furnished by the funeral director or vault company.

No grave shall be dug closer than six (6) inches from the line of any lot.

In all full burial interments, the casket shall be enclosed in a permanent outside container. Such outside container shall be installed by the funeral director, vault company, or the City's designated contractor.

In all interments of cremated remains, the container shall be installed by the City, its designated contractor, funeral director or vault company. The size of the container must be submitted with the request for burial.

All funerals within the cemetery shall be under the supervision of the City or its designated contractor. No burials are to be made on Sunday or legal holidays, except by permission of the Superintendent. Overtime charges will apply.

The City must be notified through the City Clerk or its designated contractor, of the time and exact location of proposed interments in time to allow not less than ten (10) hours of daylight to prepare the grave. If notification occurs less than 10 hours of daylight prior to burial, overtime charges will apply.

Interments that involve preparation or follow-up work during other than regular working hours will be done at an additional charge for the overtime portion of the time required. The maximum charge shall not exceed the normal charges plus the weekend/holiday fee. This fee is in addition to the normal interment or disinterment fee charged during regular working hours.

Interments of the remains of any persons other than the owner or an immediate member of his/her family will be permitted only after the written consent of the owner or the owner's authorized agent has been filed with the City Clerk or the City's designated contractor. In case of a minor being the owner, the guardian may give consent upon proof of this authority to act.

Only one (1) interment in any one grave space shall be permitted, except in the case of a parent and infant child, two (2) children dying at about the same time, or in such other unusual cases as it shall seem to the Superintendent to be proper under the circumstances. Such interments shall adhere to Section VIII Burial Rights Policy.

Up to two cremated remains may be placed in the same space if the owner of the grave space or his/her heirs purchase the right to such interments. Should the owner permit the burial of such cremated remains, only one additional memorial shall be permitted on the grave space and such memorial shall not be larger than 24 x 12 x 4 inches and installed at lawn level. Up to three (3) cremated remains (only) may be placed on a single grave space.

DISINTERMENTS

Disinterment of a burial shall be facilitated by a Michigan licensed funeral director. Said funeral director shall obtain a permit for such removal from the local health officer of Oakland County. Said funeral director shall complete the removal form as required by the City or its designated contractor. Disinterment shall not commence until after issuance of the Oakland County permit is presented to the City or its designated contractor, approval for removal is granted by the City or its designated contractor, and all applicable fees are paid. Such disinterments shall only be scheduled between June 15th and October 15th each year unless approved by the City. The grave space where the disinterment occurred shall immediately be returned to a safe condition.

VIII. BURIAL RIGHTS POLICY

Lots purchased from the City after October 1, 2014:

Full grave

One casketed remains and two cremated remains

- or -

Up to three cremated remains

Cremation grave

3 x 2 feet one cremated remains

3 x 4 feet two cremated remains

Lots purchased prior to October 1, 2014:

Full grave

One burial right per grave (To add a burial right for cremated remains, must purchase each additional right of burial in the grave. Up to two cremated remains.)

- or -

One cremated remains (To add a burial right for cremated remains, must purchase each additional right of burial in the grave. Up to two cremated remains.)

IX. LOT RESALE POLICY

All graves sold by the City after October 1, 2014 can only be returned to the City. Such graves cannot be transferred from the original purchaser to an unrelated third party. Graves can only be transferred to family according to the Rules of Consanguinity with supporting genealogical documentation.

All graves returned to the City shall receive 50% of the original purchase price from the Greenwood Cemetery Perpetual Care Fund. Upon return of the graves, the City may resell the graves.

(For the purpose this policy, immediate family shall mean the immediate family of the purchaser(s) – spouse, children, grandchildren, parents, siblings, nieces/nephews, grandparents, aunts/uncles.)

X. SCHEDULE OF FEES AND CHARGES

Fees and other charges are as set forth in the Schedule of Fees, Charges, Bonds and Insurance.

XI. REVISIONS

The obligations of the City as herein set forth may, from time to time, be modified by the Birmingham City Commission.

- October 18, 1971 Resolution No. 1434-71
- February 13, 1984 Resolution No. 02-97-84
- February 23, 2009 Resolution No. 02-52-09
- December 17, 2012 Resolution No. 12-356-12
- August 10, 2015 Resolution No. 08-174-15

©2019 Greenwood Historic Cemetery • Oak Ave, Birmingham, Michigan 48009 • Phone: (313) 567-3453

Cemetery Services
Traditional Burial

About Greenwood
About Us

Resources
Links

The Elmwood Family of Cemeteries

Preplanning
Schedule of Charges
Cremation
Markers and Memorials
Contact Us
Directions

Our History
Rules and Regulations
Map
Photo Gallery

Definitions
Historic Elmwood Cemetery
Glenwood Cemetery



GLENWOOD
CEMETERY





1-1-2003

Survey Methodology for the Preservation of Historic Burial Grounds and Cemeteries

Frank G. Matero

University of Pennsylvania, FGMATERO@design.UPENN.EDU

Judy Peters

University of Pennsylvania, jpeters2@design.upenn.edu

Reprinted from *APT Bulletin*, Volume 34, Issue 2/3, 2003, pages 37-45.

We have contacted the publisher regarding the deposit of this paper in ScholarlyCommons@Penn. No response has been received.

This paper is posted at ScholarlyCommons. http://repository.upenn.edu/hp_papers/5

For more information, please contact repository@pobox.upenn.edu.

Survey Methodology for the Preservation of Historic Burial Grounds and Cemeteries

Abstract

An integrated program of digital surveying and mapping can provide a powerful database for the analysis, conservation, and management of historic burial grounds and cemeteries.

Comments

Reprinted from *APT Bulletin*, Volume 34, Issue 2/3, 2003, pages 37-45.

We have contacted the publisher regarding the deposit of this paper in ScholarlyCommons@Penn. No response has been received.

Survey Methodology for the Preservation of Historic Burial Grounds and Cemeteries



Frank G. Matero; Judy Peters

APT Bulletin, Vol. 34, No. 2/3. (2003), pp. 37-45.

Stable URL:

<http://links.jstor.org/sici?sici=0848-8525%282003%2934%3A2%2F3%3C37%3ASMFTPO%3E2.0.CO%3B2-J>

APT Bulletin is currently published by Association for Preservation Technology International (APT).

Your use of the JSTOR archive indicates your acceptance of JSTOR's Terms and Conditions of Use, available at <http://www.jstor.org/about/terms.html>. JSTOR's Terms and Conditions of Use provides, in part, that unless you have obtained prior permission, you may not download an entire issue of a journal or multiple copies of articles, and you may use content in the JSTOR archive only for your personal, non-commercial use.

Please contact the publisher regarding any further use of this work. Publisher contact information may be obtained at <http://www.jstor.org/journals/APTech.html>.

Each copy of any part of a JSTOR transmission must contain the same copyright notice that appears on the screen or printed page of such transmission.

JSTOR is an independent not-for-profit organization dedicated to and preserving a digital archive of scholarly journals. For more information regarding JSTOR, please contact support@jstor.org.

<http://www.jstor.org>
Tue Jan 9 14:00:33 2007

APT BULLETIN

Vol. XXXIV, No. 2-3

2003



THE JOURNAL OF PRESERVATION TECHNOLOGY

The Association for Preservation Technology



Association pour la préservation et ses techniques

Survey Methodology for the Preservation of Historic Burial Grounds and Cemeteries

FRANK G. MATERO and JUDY PETERS

An integrated program of digital surveying and mapping can provide a powerful database for the analysis, conservation, and management of historic burial grounds and cemeteries.

There are few places which we visit with more interest than old burial grounds, so frequent in our early settlements, and in which the dust of our ancestors is laid. We observe in their appearance a charming simplicity, that attracts the attention of all visitors, enlists their sympathies with the dead, and excites a tender veneration for their memory.¹

As man is the only animal that buries the dead,² then cemeteries and burial grounds, as final repositories, represent the largest material correlate associated

with the rituals and commemorations relating to death. The layout and design of monuments, tombs, and grave markers, motifs and inscriptions, and plantings and immortelles reveal our collective and personal responses to death, as well as much about our attitudes toward life.

Cemeteries and burial grounds and their mortuary structures, monuments, and associated features are rich and complex cultural landscapes. Although their formal aspects have long been

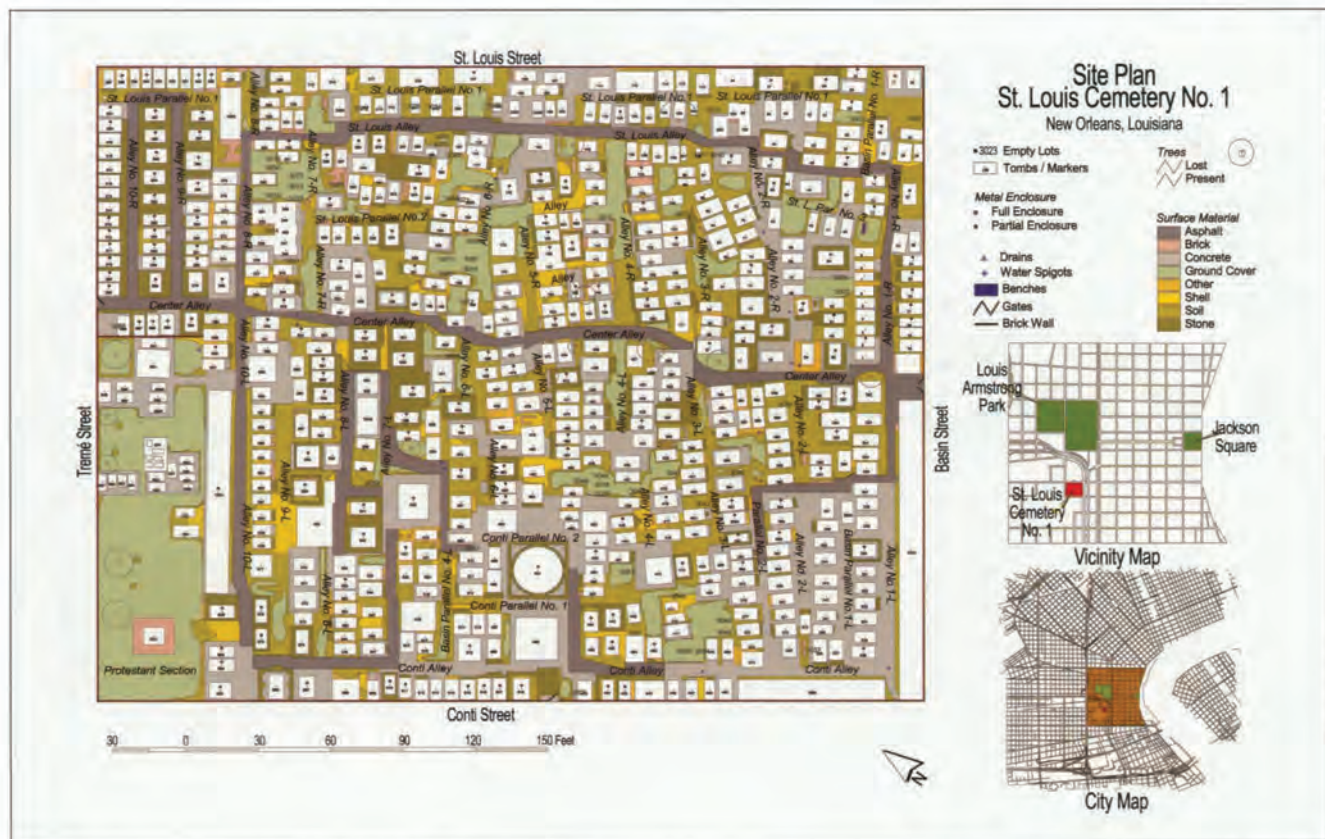

Fig. 1. The digital site map for St. Louis Cemetery No. 1 showing all tombs, markers, metal enclosures, and primary defining features, such as paths, ground surface, and vegetation. Final map layout by John Hinchman. Courtesy of the Architectural Conservation Laboratory, University of Pennsylvania.

studied, these landscapes beg renewed consideration, as J. B. Jackson has observed, as “social constructs formed over time” rather than only as designed entities.³

Critical to the problems of the preservation of these sites is an understanding of their past and current meanings and acquired associations beyond the primary physical and spiritual necessities of burial. For many older cemeteries and burial grounds, their transformation into heritage tourist sites has brought new problems, including commercialization, looting, vandalism, and overzealous or inappropriate restoration. Underlying these problems is the more fundamental question of the continued relevancy and practicality of these sites as sacred burial places. Shifting and declining populations, redevelopment of surrounding land, space limitations, and changes in burial practice and religious observance have all diminished their ability to function as places for the interment and veneration of the dead. As a result, many have been abandoned. Conversely, at some sites, such as St. Louis Cemetery No. 1 in New Orleans, increasing numbers of tourists have presented problems relating to visitor safety, owner liability, and access, while the rising market value of cemetery art has escalated the need for better protection from theft and vandalism.

During the latter half of the nineteenth century, many American Colonial-era burial grounds, long discontinued as places of interment, became symbols in the construction of a national identity memorializing persons associated with the founding of the country. Interest in these burial grounds paralleled that shown in houses and other sites associated with Revolutionary War personages and the nation’s colonial past, and they played a role in the commemoration of these individuals as public ancestors.

As early as 1851 Thomas Bridgeman crusaded for the preservation of Boston’s early burial grounds.⁴ His published arguments provide some of the first scholarly support for the cultural and historical value of American burial grounds and their protection. Further recognition of the importance of

cemeteries beyond their obvious function was generated by nineteenth-century scientific interest in the weathering of stone, as observed and measured in many ancient burial grounds;⁵ by antiquarian interest in tombs and grave markers as stylistic and epigraphic artifacts; and by the rural-cemetery movement, which established cemeteries as places for contemplation and recreation.

Defining Necrogeography

Necrogeography is a term believed to have been first used by Fred Kniffen in 1967 to describe the spatial and cultural dimensions of mortuary landscapes.⁶ Necrogeographies can range from a simple burial or tombstone to the complex, landscaped cemetery sites of the nineteenth and twentieth centuries. Determining what constitutes proper preservation and management of this unique class of cultural property requires an understanding of the origins of each site, as well as how changes in customs and attitudes over time have affected a site’s use, form, meaning, and preservation.

Beyond their practical purpose and cultural meaning, necrogeographies provide important information. Inscriptions can record birth and death dates, ethnicity, sex, life span, migration, occupation, social status, religion, and other demographic information. Tombs and markers can function as outdoor laboratories for scientists, conservators, architects, and sculptors studying the performance of many common materials, especially stone and metal, that have been subjected to harsh environmental conditions and to different methods of treatment. This use was recognized as early as 1883 by Dr. Alexis Julian in a lecture read before the New York Academy of Sciences:

There could hardly be devised a superior method for thoroughly testing, by material means, the durability of stone, than by its erection in this way [as a grave marker], with a partial insertion in the moist earth, complete exposure to the winds, rain and sun on every side, polished and sharply incised with dates, inscriptions, and carvings, by which to detect and to measure the character and extent of its decay.⁷

Yet despite their importance as cultural, historical, scientific, and scenic resources, necrogeographies and their monuments are endangered. Much of this problem can be attributed to the logistical complexity inherent in these sites: they contain markers of varied materials, design, and age; and they are subject to damaging environmental effects, both natural and human. Also, many seventeenth- and eighteenth-century urban burial grounds were destroyed or significantly altered in the nineteenth century in the belief that they were a source of disease and the cause of epidemics.

In order to ensure their preservation, various survey methods have been developed and utilized to record site, tomb, and marker information and to manipulate the data for historical and anthropological research. Fewer attempts have been made to expand the survey process to study site evolution over time or to conduct analyses of physical conditions and use for comprehensive conservation planning and management. Such efforts have formed the basis for an integrated program of documentation, conservation, training, and public outreach in recent work at St. Louis Cemetery No. 1 in New Orleans.⁸

Developing the Conservation Plan

A review of preservation and cultural-resource literature revealed that despite a plethora of public and private projects involving documentation and treatment of historic cemetery sites, little information has been published, except in cemetery-specific or regional guidelines.⁹

As with all heritage sites, the preservation of historic burial grounds and cemeteries requires a methodology based on principles, practices, and procedures. The following components define a basic, sequential conservation program for any historic cemetery or burial ground:

1. Documentation, recording, and analysis of the site and surrounding context (e.g., urban), including individual monuments, tombs, and landscape features through archival and field

- research, as well as ethnographic recording of past and present uses.
2. Survey of site condition, including investigations of deterioration and characterization of biotic and abiotic features.
 3. Development of an emergency program that includes fragment collection, inventory and storage, and temporary protection and stabilization of tombs and monuments.
 4. Development of a phased treatment program for individual resources based on historical and cultural values, significance, condition, and integrity.
 5. Testing and execution of model treatments and the development of standards and guidelines for conservation.
 6. Preparation of a site conservation plan, including strategies for intervention and maintenance, as well as social and economic development and public outreach.

These six steps inform all preservation work. Additionally, the implementation of standards for documentation and treatment enhances opportunities for comparative analyses, dialogue, and planning across individual historic cemetery sites and projects.

Documentation and Recording

Documentation and recording of qualitative and quantitative information are the foundation for any conservation program.¹⁰ Past and present information on type, style, materials, design, environment, conditions, and use informs the analyses, diagnoses, and treatments required to ensure the long-term viability of any historic resource. Documentation provides the baseline that is essential to assess a site, prioritize the necessary work, and manage the resources.

Information should be compiled from archival images and other documentary sources, interviews, and physical evidence. The sources and methods chosen depend on the scope and objectives of the project. Historic cemeteries and burial grounds are usually well repre-

sented in both image and primary source materials in local archives. With sites that are still used or have only recently closed, interviews can provide valuable insights into the physical and social history of the site and individual monuments.

Inferred data, or educated guesses, based on physical evidence or observations of the surrounding monuments and landscape, can cautiously be used to bridge information gaps when no written data or images are available. The recording of site-wide observations is also a critical step in the documentation phase. What patterns of site evolution and tomb and marker typology can be constructed? How do material, design, orientation, environment, and past maintenance affect performance? Observed patterns help refine hypotheses for analyses.

An important product of the recording process is the development of a site map that identifies all individual monuments and site-defining features, such as paths, topography, water systems, walls, vegetation, and all other built or natural features. New technologies now make it possible to produce more accurate and comprehensive documentation by combining digital-imaging applications with tabular information stored in relational databases. A relational database stores information in multiple files or separate tables linked together (or related) by data elements that the files or tables have in common. Layered digital site maps allow visualization and analysis of the site through time, by individual features, by conditions, or by any combination of data collected. The database-connected map enables information on future treatment and maintenance information to be added, making it a valuable tool for ongoing site management (Fig. 1).

A field-survey form coordinated with the database should be used. All terms used and the methods of data collection should be documented in an illustrated survey manual. Basic information should include:

- Site specifics (address, locator information, contacts)
- Survey information (date, weather, surveyor)

- Tomb or marker identification (reference number, location, orientation, dimensions, precinct/enclosure, sketch)
- Monument or marker type and style
- Construction, alteration, and restoration dates
- Builder, architect, stone carver
- Materials and construction
- Inscriptions and iconography
- Other features (such as plaques, planters, furniture, metalwork)
- Status (relocated, altered, replica/replacement, fragmented)
- Treatment history
- Condition, form integrity, and material integrity¹¹
- Proposed treatments

Condition Survey and Assessment

The development of a comprehensive conservation program requires a thorough understanding of existing conditions. A condition-assessment survey must outline clearly what information is required and why. Consistent terminology should be specified for use and explained in a survey manual. The information should be presented to reveal broader patterns and trends of physical transformations over time.

Condition has many determinants. These include, in general order of occurrence:

- Original design, materials, and construction
- Subsequent changes through use, natural causes, and human interaction
- Micro- and macro-environments
- Disuse and/or abandonment
- Repair, reuse, and maintenance

As deterioration most often occurs over a considerable period of time, its study poses an enormous challenge. The most comprehensive method of study is continuous long-term monitoring, which is costly, time consuming, and not possible for many sites. The most feasible alternative is a periodic, systematic

methodology of descriptive recording and reevaluation of symptomatic conditions data, with information recorded under reproducible conditions at specific intervals over time. In this way, the variables of condition — including type, location, extent, and severity of damage — can be assessed alone, together, and in combination with other factors such as materials, design, construction, environment, use, modification, maintenance, and treatments.

By considering performance, deterioration, and treatment in a holistic and integrated manner, linking design, environment, and human agency, conservators can develop and apply documentation and recording methods focused on etiological concerns.¹²

Undertaking a tomb and marker condition-assessment survey can be a daunting task, given the sheer number and variety of types, materials, and conditions. All condition-assessment surveys depend on complementary levels of qualitative and quantitative recording that describe the type, location (micro or macro), status (active or inactive), and extent or degree of severity for each condition. Historical or otherwise previously recorded information, where it exists, should be included. The medium or format by which new information is gathered depends on what is being described, the size and scale of the work, the degree of accuracy required, and the equipment, skill, and time available.

Terminology should often be accompanied by photographic and schematic illustrations, the latter identifying differ-

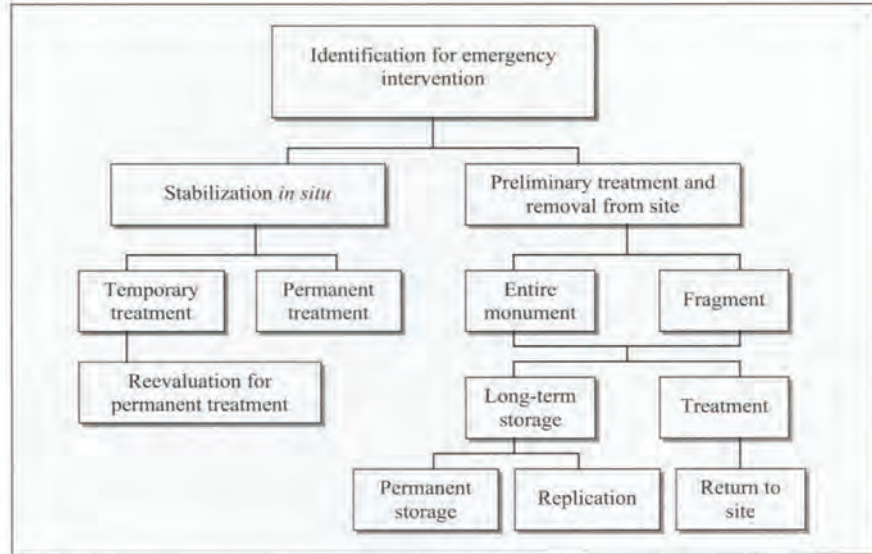

Fig. 6. An intervention decision-tree for historic tombs and markers. Diagram by Frank Matero.

ent conditions and materials, all of which can be incorporated into the project database and digital maps. Classification schemes are usually designed to serve a specific end, such as preparation for treatment or monitoring deterioration. They represent an artificial hierarchical typology of the variables observed.

Once a database and its accompanying survey have been developed and tested, data collection and management can begin. The database and graphic software available today allows for flexible and detailed analysis and visual display of information, facilitating the interpretation of data for diagnostic purposes and for developing manage-

ment strategies, including preventive conservation. Today's state-of-the-art condition surveys far exceed earlier methods of recording the physical details of before-and-after treatments.

Emergency Treatment Program

Because of the large numbers of monuments in most historic cemeteries and burial grounds and the unlikelihood of immediate and continuous conservation treatments, emergency measures are often required before a full assessment can be made or before the condition survey can be completed (Figs. 2–5).

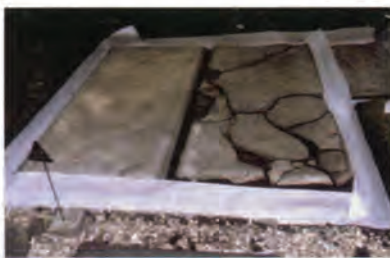

Fig. 2. Emergency stabilization by means of temporary reburial with sand and geofabric "pillows." Photograph by Frank Matero.



Fig. 3. Emergency stabilization using temporary gauze facing. Photograph Frank Matero.



Fig. 4. Emergency stabilization by using an open-roofed shelter. Photograph by Frank Matero.



Fig. 5. Emergency stabilization using a closed, ventilated box around the structure. Photograph by Frank Matero.



Fig. 7. Bergamini Tomb, St. Louis Cemetery No. 1, New Orleans, before. Photograph by D. Krotzer.



Fig. 8. Bergamini Tomb, after. Preservation of existing form and materials through repair and maintenance. Photograph by D. Krotzer.



Fig. 9. Perrault Tomb, St. Louis Cemetery No. 1, New Orleans, before. Photograph by D. Krotzer.



Fig. 10. Perrault Tomb, after. Partial restoration through repair of roof and missing stucco. Photograph by F. Matero.

Any or all of the following usually constitute emergency conditions: structural instability, public-safety issues, large-scale material losses due to accelerated decay, instability of significant details such as carving or inscriptions, and imminent danger of theft or vandalism.

Although usually not feasible, the emergency “treatment” of choice is temporary removal and storage until the full site assessment and conservation plan can be completed. In situ stabilization of stonework with seriously flaking, scaling, delaminating, or sugaring surfaces or with loose, small fragments can be achieved with temporary facings of wet-strength tissue paper or gauze and a reversible synthetic adhesive. Where greater in situ protection from wind and water is required, temporary protective shelters made of wood; a breathable, water-repellent fabric; or a geotextile are recommended. Ground slabs may be protected temporarily by partial reburial under geotextile sand bags. These shelters can be left in place until time and funds allow for more permanent treatment.

Because fragments and other loose elements are very vulnerable to theft, vandalism, and collapse, a program of fragment collection, inventory, and safe storage should be initiated as soon as possible. This effort is invaluable for the future matching of fragments to parent monuments.

Phased Treatment Program

A separate numerical rating system for each tomb material’s condition, form integrity, and material integrity and for the significance of each marker, tomb, or component should be utilized. The data can then be analyzed based on the values of individual or combined attributes. In this way, a complete and integrated assessment of each marker is possible, leading to priority lists for phased stabilization, treatment, management, and maintenance programs. Overall site priorities based on condition, integrity, interment status, and significance of the individual monuments and of the individuals interred can then be developed. This approach is necessary to prioritize large numbers of monuments requiring immediate attention when time and resources are limited. These value-weighted ratings help decision makers follow the paths in an intervention decision tree (Fig. 6).

Model Treatments and Guidelines

After a survey has been completed and the information synthesized, standards and guidelines for the work and proposed treatments can be developed through laboratory and field testing and then executed in model projects on site in order to illustrate the range of materials, techniques, and recommended approaches. Projects should provide performance data over an accepted period

of time, usually not less than one year. This data can also provide a reasonably accurate prediction of conservation costs and skill and time requirements, information that can be used for scheduling work and for fundraising (Figs. 7–10).

Ultimately the aim of the preservation of outdoor monuments and sites is to augment the stability of the materials in situ by halting or retarding detrimental processes or by removing situations that threaten the continued existence of these works. In the case of historic burial grounds and cemeteries, this often translates into preferential respect for historic design and intent, the retention of as much historic fabric as possible, and the use of compatible but discernible replacement materials where needed. Recarving historic material generally is to be avoided, and relocation of monuments off site is not desirable since most cemeteries are public places. The materials and techniques selected, whether traditional crafts or specialized conservation, must address not only the structural requirements of the monument but also levels of exposure and issues of access and public safety. This process often requires a modification of the principle of reversibility of treatment to one of re-treatability. In general, every effort should be made to restore the visual syntax of the entire site through the structural and visual reintegration of the individual markers, the tombs, and their landscape.

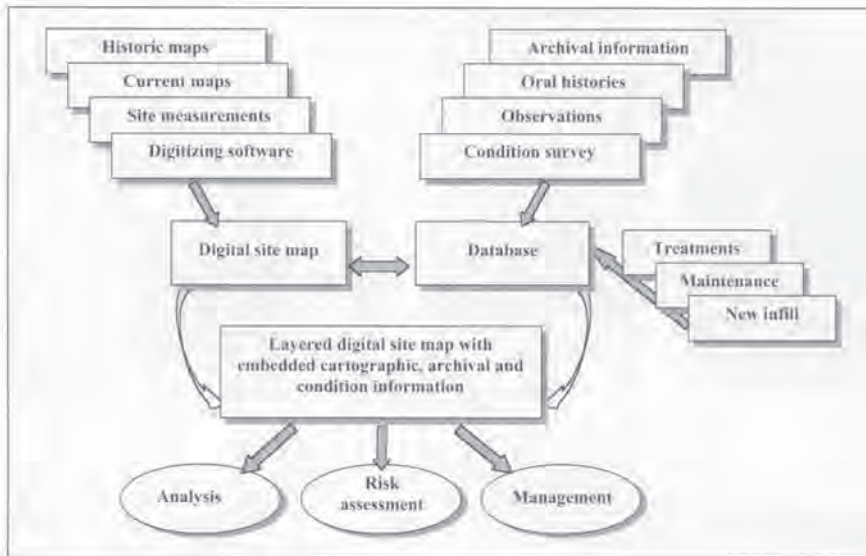

Fig. 11. Linking digital tools for enhanced information management. This diagram shows how the many categories of data (archival, verbal, field surveys, test data), as well as the later generation of treatment, maintenance, and new-construction data, can be linked to a digital map to be used for problem solving, preservation planning, and site management. Diagram by Judy Peters.

Tested conservation techniques should be appropriately incorporated into standards and guidelines to reflect site-specific materials, monuments, decay mechanisms, and environmental issues. The project team for St. Louis Cemetery No. 1 prepared a manual of illustrated guidelines that included extensive recommendations specific to above-ground tombs. The product was targeted to tomb owners and cemetery managers.¹³

Digital Documentation and Analyses

Historic burial grounds and cemeteries generally contain numerous site-defining features, and a large quantity of information will be generated during the course of a well-documented project. Efforts to maximize the information can benefit greatly from the creative use of digital tools for recording, analyses, information management, and presentation. The development of a relational database that is linked to a geographic information system (GIS) and that allows the mapping and analysis of spatial data, should be part of the planning process from its inception. This combination of digital tools with archival research and field recording can improve

the efficiency of historical research, the speed and accuracy of surveys, and the quantity and quality of archival information directly hyper-linked to site features. This combined approach can also become the tool for future documentation of treatments, maintenance, and changing conditions. Digital tools provide powerful analytical capabilities and can enhance the generation of creative presentations for project discussions, funding proposals, and public outreach (Fig. 11).

Although CAD, GIS, and relational databases are well understood individually and are in common use at preservation firms, most historic cemeteries and burial grounds do not have a GIS base map and have not developed a relational database to facilitate site-wide preservation planning. Commercial cemetery-management software is available to map plots and facilitate burial record keeping, and some of these packages incorporate GIS. However, these systems have been developed for modern cemetery management and generally do not address monument conservation needs or long-range site preservation planning.

Acquiring the commercial software for computer-aided design (CAD) and developing a GIS relational database can

cost \$5,000 to \$10,000, depending on the options or enhancements selected. However, once this investment is made, the programs can be used to link data, maps, and images from multiple projects of all sizes, and in-house use can eliminate the need for expensive, outsourced project-specific software development, which is generally unnecessary and difficult to maintain over time.

Establishing a digitized site map.

Layers of historic and current site information can be captured and digitized through the use of widely available CAD (e.g., Autodesk, AutoCAD) and geographical information system (e.g., ESRI ArcView) software. Geographic information systems are designed for the efficient acquisition, analysis, synthesis, and presentation of cartographic data and also allow the mapping of any collectible information that can be expressed as cartographic symbols such as polygons, dots, or lines. Fine-level survey data captured through Total Survey Stations (TSS) or coarse measurements taken with hand-held global positioning systems (GPS) can be loaded directly into CAD, GIS, spreadsheet, and database software. Data from traditional hand-measurement and digital-survey techniques can also be incorporated into the data tables to define existing boundaries, markers, tombs, and landscape features for mapping. Historic maps, USGS maps, and local planning maps can be “rubber-sheeted” within the GIS software to assist in the development of the base map or to create informative historic layers. Rubber-sheeting allows the historic map image to be incorporated as a layer in the GIS and manipulated so that the land features and boundaries line up with the current digital map data. There is a wealth of high-resolution aerial photography available, both commercially and within local governing bodies, that can also be incorporated.

Currently, most site layers are initially developed in a CAD program and then transferred to GIS software as closed polygons, points, and lines. Improvements to the newer versions of GIS allow facade features, new layers for treatments, or new site developments to be prepared directly through GIS. With

either tool, maps can be digitized for multiacre cemetery sites or for very small areas, such as a tomb-facade condition assessment. The development of the digital map for St. Louis Cemetery No. 1 can be seen in Figure 12.

Documentation requirements and survey forms. Different types of documentation can be collected at all stages of the project and incorporated into the project database. Research from primary and secondary sources, historic and current photographs and maps, past alterations or treatments, architectural elements, materials, current conditions, treatments, results of physical tests, and maintenance events can all become entries linked to the features of the digital site map. Data can be captured as searchable text in the form of a short comment, dates, numbers, calculations, charts, and images. The type and quantity requirements for documentation will dictate the design needs of the database.

The power of the digital-database-to-map connection is most obvious with large amounts of survey data, such as in a condition survey or architectural-significance survey. Working with the database design, the survey content and format must be optimized to ensure ease of use, accuracy, and the most meaningful collection of data for later mapping and analyses.

Relational database, data entry forms, and reports. After documentation requirements and survey questions are confirmed, then data fields, forms, and reports are developed, and the primary linking field of the database can be established using the survey coding system and vocabulary. Data fields that force surveyors to select from a list of materials produce more meaningful maps than data fields permitting the use of any text, any spelling, or numerous yes/no answers. The assignment of value-weighted numerical ratings to defined terms enables qualitative assessment terms to be used quantitatively, leading to more meaningful maps, comparisons, and summarization of data.

Complete and accurate recording of all pertinent data is the goal, so data entry forms should be user-friendly, and all team members should participate in

training sessions early in the process. The training often provides valuable feedback for the database developers, highlighting areas of confusion. For the St. Louis Cemetery No. 1 documentation and survey data, Microsoft Access worked well as the database program because of its recognizable interface, its ability to pull data to and from spreadsheets and GIS, and its ease of use. Computerized forms and reports were created to match the paper field-survey forms closely. For large cemetery surveys, field data collection with handheld computers is a cost-effective method for reducing error and ensuring rapid data entry.

Linking site map and database. The database is linked directly to the GIS mapping program through an ODBC (Open Data Base Connectivity) translator, available through the basic Windows operating system. This allows a direct SQL (Structured Query Language) connection from within the GIS program. The links can be set up before any data are collected so that each time the GIS program loads, it links to the current version of live database tables and established queries, or it questions how the data sets relate. Once the link has been established, additional tables and queries of interest can be brought into the GIS as new layers or combined with existing layers to answer future queries (Fig. 13).

Analysis, interpretation, and communication of information. Both the relational database and the GIS software contain extensive analytical and presentation capabilities. Depending on the question or desired output result, either tool can be used. Additionally, the data from the tables of both programs can be exported to spreadsheets for further charting and graphing capabilities. Layers of historical development and typology or condition can best be related in a visual format created through the GIS software. Complicated queries, reports, and calculated summaries can best be processed through the database and then charted through the GIS or spreadsheet-charting tool. Summaries and comparisons often are more clearly conveyed by means of charts and

graphs. If the original map digitization was prepared in sufficient detail, complete material and condition mapping of tomb or marker surfaces can be achieved, with mathematical calculations possible for each deterioration condition, as suggested in earlier work by B. Fitzner.¹⁴ Each of these data displays, used in the right context, ensures that the final conservation plan is based on solid fact. This leads to informed decision making for the appropriate conservation treatments, funding priorities, and long-term site management.

By following a consistent digital approach to data collection, additional avenues for analysis and presentation become available. In the St. Louis Cemetery No. 1 project, participants developed three-dimensional models of the site by use of color, height, and roof-form data. Historical research resulted in timelines and scaled urban-context maps reflecting changes through time. Historical travel accounts were analyzed and used to map tour routes, significant events, and people as they related to specific tombs. Data collected on tomb changes over time allowed a progressive display of the morphological evolution of individual tombs, as well as of the entire site (Fig. 14).

The maps, analyzed data, and recommendations from the St. Louis Cemetery No. 1 project are presented on an educational Web site, which was developed using Web-design and animation-software tools. Dynamic pages allow users to query the project database directly, and GIS maps with "clickable hot spots" show summary data and a thumbnail image for each tomb. This versatile means of public outreach was chosen to meet the needs of local students and supporters, interested visitors, cemetery managers, and future researchers.¹⁵

Conclusion

Assessing and planning for the conservation needs of historic cemeteries and burial grounds can be a difficult task due to the sheer volume of tombs, markers, and other built memorial structures, as well as the many important landscape features. The conservation methodology discussed above was greatly enhanced

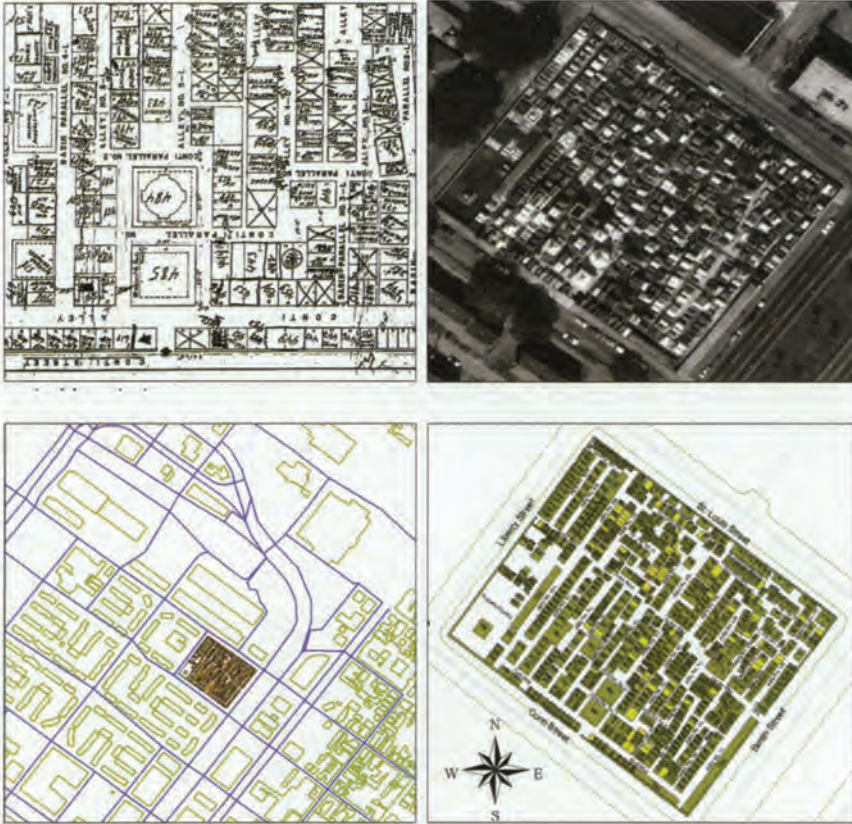

Fig. 12. The development of a site map. Top left: An earlier (c. 1940) hand-drawn survey map identifies tomb plots and numbering. Top right: A 1972 aerial photograph showing exact placement of tombs and features. Bottom left: A city-commission data layer positioning the site within the neighborhood. Bottom right: The new site base map georeferenced and projected within the World Coordinate System. Sequence by Judy Peters.

through the use of a conservation-focused database linked to a digital site map. This rich geographical information system enabled visualization of the site through time, provided decision making capabilities to assess significance and urgency for treatments, and will continue to serve as a tool for site-management and public outreach.

FRANK G. MATERO is the department chair for the Graduate Program in Historic Preservation and director of the Architectural Conservation Laboratory and Research Center at the University of Pennsylvania.

JUDY PETERS is a Kress Architectural Conservation Fellow working on the Save America's Treasures project with the Architectural Conservation Laboratory and Research Center at the University of Pennsylvania.

Acknowledgments

The authors wish to thank Michael Boudreaux (Archdiocesan Cemeteries of New Orleans) and Louise Fergusson (Save Our Cemeteries) for their support and Lindsay Hannah, John Hinchman, and Dorothy Krotzer for their assistance during the site survey. We also wish to thank Robert Cheetham for assistance in the development of the GIS.

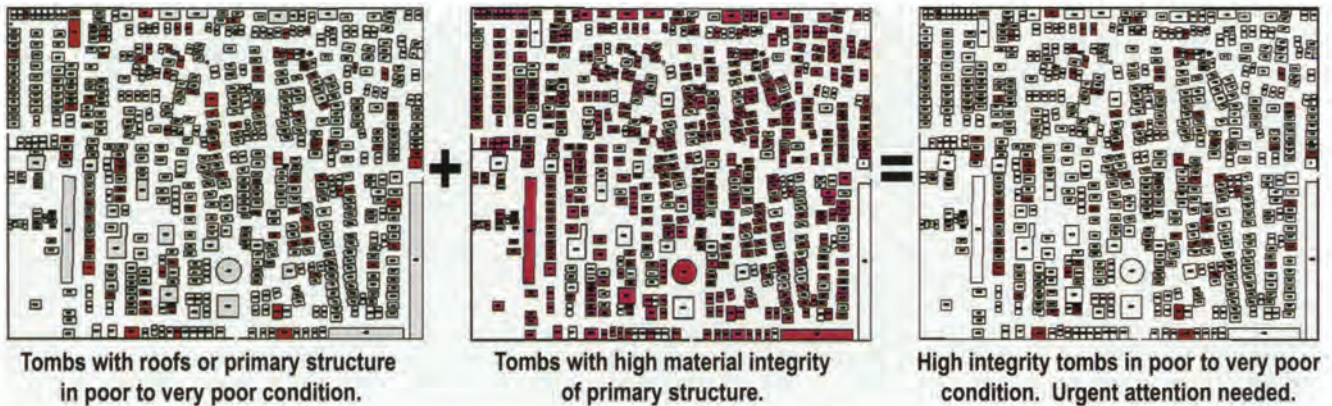

Fig. 13. Site maps with condition and integrity data mapped. The GIS maps provide enhanced visual references for site and resource issues, and the embedded information becomes available for extensive analyses, comparisons, and calculations. The combination of tombs in poor to very poor condition with tombs displaying high material integrity, allows the identification of a select group of tombs requiring the most urgent attention. Sequence by Judy Peters.

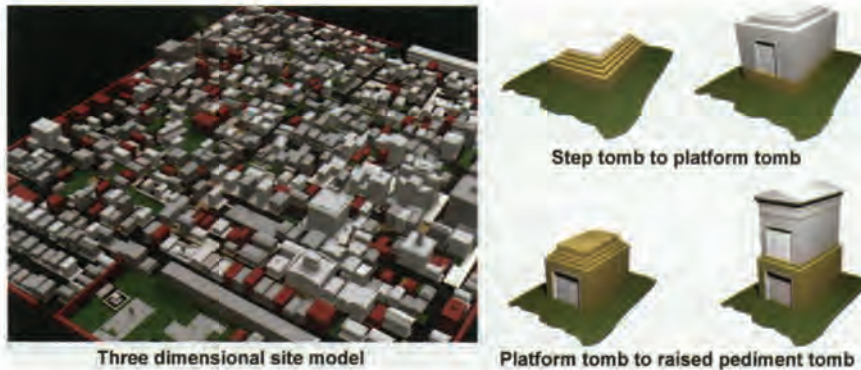

Fig. 14. A three-dimensional site model and two representative tomb-modification sequences. Digital visualization of site evolution over time and tomb type can be created easily using the survey data. Model by S-Y. Lu and sequence by John Hinchman.

Notes

1. Wilson Flagg, *Mount Auburn: Its Scenes, Its Beauties, and Its Lessons* (Boston and Cambridge, 1861), 114.

2. Louis Vincent Thomas, *Anthropologie de la mort* (Paris: Payot, 1975). Quoted in Michel Ragon, *The Space of Death: A Study of Funerary Architecture, Decoration, and Urbanism*, trans. Alan Sheridan (Charlottesville: University Press of Virginia, 1983), 4.

3. John B. Jackson as quoted by Paul Groth, "Frameworks for Cultural Landscape Study," *Understanding Ordinary Landscapes*, ed. Paul Groth and Todd W. Bressi (New Haven: Yale Univ. Press, 1997), 21.

4. Thomas Bridgeman, *Memorials of the Dead in Boston* (Boston: B. B. Mussey & Co., 1853).

5. See, for example, Thomas Egleston's, "The Cause and Prevention of the Decay of Building Stone," *American Society of Civil Engineers Transactions* 15 (October 1886): 647-715. Egleston discusses the condition and deterioration of markers in Trinity and St. Paul's burial grounds. See also Archibald Geikie, "Effect of Weather on Tomb-Stones," *The American Architect and Building News* (July 10, 1880): 21. Geikie discusses his research on the deterioration of dated tombstones as a method to evaluate the effect of time and weather on various types of stone.

6. Fred B. Kniffen, "Necrogeography in the United States," *Geographical Review* 57 (1967): 426-427.

7. Alexis Julian, "The Decay of Building Stones in New York City: Papers Read Before New York Academy of Sciences January 29, and April 30, 1883," *American Architect and Building News* 13, no. 373 (1883): 76-78. The papers featured his research on stone in buildings and graveyards in and around New York City.

8. This project was developed by the Department of Historic Preservation and Landscape Architecture at the University of Pennsylvania, under the direction of Frank Matero and Dana

Tomlin and in collaboration with the Preservation Studies Program of the School of Architecture of Tulane University. Funding was provided by the Louisiana Division of Historic Preservation, Office of Cultural Development, and the Samuel H. Kress Foundation in collaboration with Save Our Cemeteries, Inc., and the Archdiocesan Cemeteries of New Orleans. Field survey data were collected by the graduate students in a 2001 collaborative studio at the University of Pennsylvania and subsequently analyzed by a research team consisting of Stephen Curtis, John Hinchman, Sophie Middlebrook, Al Parker, Judy Peters, and Kyu-Bong Song.

9. Most of the available literature is incorporated in guidelines published by the National Trust, the National Register, or various state or local preservation offices. See Elizabeth Potter and Beth M. Boland, "Guidelines for Evaluating and Registering Cemeteries and Burial Places," *National Register Bulletin* 41 (Washington, D.C.: National Park Service, 1992). Lynette Strangstad, *Preservation of Historic Burial Grounds* (Washington, D.C.: National Trust for Historic Preservation, 1993). Sharyn Thompson and Lynette Strangstad, *Florida's Historic Cemeteries: A Preservation Handbook* (Tallahassee: Historic Tallahassee Preservation Board, 1989). Frank G. Matero, et al., *A Conservation Program for Louisiana's Above Ground Cemeteries* (New York: Center for Preservation Research, 1987). Tamara Anson-Cartwright, ed., *Landscape of Memories: A Guide for Conserving Historic Cemeteries* (Toronto: Ministry of Citizenship, Culture and Recreation, 1997). English Heritage, "Paradise Preserved," at <http://www.englishheritage.org.uk>, March 2003. National Trust for Australia (NSW), *Guidelines for Cemetery Conservation*, <http://www.nsw.nationaltrust.org.au/cemscontents.html>, May 2003.

10. "The conservation professional has an obligation to produce and maintain accurate, complete, and permanent records of examination, sampling, scientific investigation, and treatment" (American Institute for Conservation of Historic and Artistic Works, "Code of Ethics of the American Institute for Conservation of Historic and Artistic Works"

and "Guidelines for the Practice of the American Institute for Conservation of Historic and Artistic Works," *AIC Directory* [Washington, D.C.: American Institute for Conservation of Historic and Artistic Works, 2003], or online at <http://aic.stanford.edu/pubs/ethics.html>).

Recording and documentation are separately defined by ICOMOS in Robin Letellier, "Recording, Documentation and Information Management Guidelines for World Cultural Heritage (draft)" (paper presented at the 11th ICOMOS General Assembly, Sofia, Bulgaria, October 5-9, 1996), Annex 1.

11. When evaluating the integrity of tombs and markers, integrity of both form and material should be rated. Definitions developed during the St. Louis Cemetery No. 1 project included "Form integrity: The extent of existing original form and details,..." and "Material integrity: The extent of existing original material,..." The full survey manual and form can be accessed at <http://www.noladeadspace.org>.

12. At the Trinity Church Burial Ground, New York City, unusual discoloration and deterioration of many of the sandstone monuments was finally identified from church records to be the result of a hot paraffin wax treatment (the Caffall process) applied in 1924. Once identified and dated, this information was verified using analytical techniques, and appropriate cleaning measures were prescribed based on the knowledge of these past treatments.

13. Frank Matero, S. Curtis, John Hinchman and Judy Peters, *St. Louis Cemetery No. 1: Guidelines for Preservation and Restoration* (Philadelphia: Univ. of Pennsylvania, 2002). Can be accessed at <http://www.noladeadspace.org>.

14. Bernd Fitzner, "Weathering Forms at Natural Stone Monuments: Classification, Mapping and Evaluation," *International Journal for the Restoration of Buildings and Monuments* 3, no. 2 (1997): 105-124. Fitzner refers to a proprietary software program for analyzing the data collected using the categories he suggests. Geographical systems now available can easily handle large quantities of data to show spatial correlations or to make mathematical calculations of areas of deterioration. Measured drawings (by hand or AutoCAD) or rectified photography images can be used as the base. Published literature on the use of GIS for historic preservation primarily features mapping of historic districts or large cultural landscapes. Small-scale surface mapping of conditions, treatments, or sample locations is an area of research that holds considerable promise.

15. More examples of GIS mapping and analysis of the survey data can be found at <http://www.noladeadspace.org>.