

NOTES:

1. STABILIZED CONSTRUCTION ENTRANCE SHALL BE CONSTRUCTED OF 3" TO 6" WASHED, ANGULAR ROCK. MATERIAL SHALL BE PLACED TO A MINIMUM THICKNESS OF 6 INCHES.
2. LENGTH OF ENTRANCE SHALL BE A MINIMUM OF 50 FEET. WIDTH SHALL BE A MIN. OF 15 FT OR GREATER IF NECESSARY TO COVER ALL VEHICULAR INGRESS AND EGRESS. PROVIDE AMPLE TURNING RADII.
3. THE ENTRANCE SHALL BE KEPT IN GOOD CONDITION BY OCCASIONAL TOP DRESSING WITH MATERIAL AS SPECIFIED IN NOTE 1.
4. ACCESSES SHALL BE INSPECTED WEEKLY DURING PERIODS OF HEAVY USAGE, MONTHLY DURING NORMAL USAGE, AND AFTER EACH RAINFALL, WITH MAINTENANCE PROVIDED AS NECESSARY. PERIODIC TOP DRESSING SHALL BE DONE AS NEEDED.

REV.	DATE	DESCRIPTION
△		
△		
△		

CITY OF SACRAMENTO
DEPARTMENT OF UTILITIES

STABILIZED CONSTRUCTION
ENTRANCE

APPR'D BY:  NO SCALE
DATE: 3/12/20 DWG. NO. **Q-10**

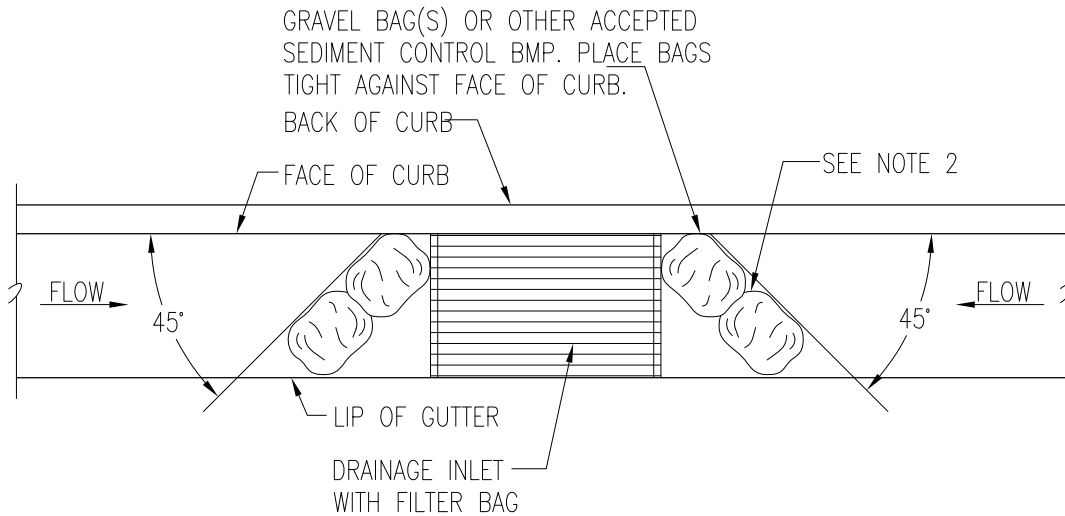

PLAN VIEW

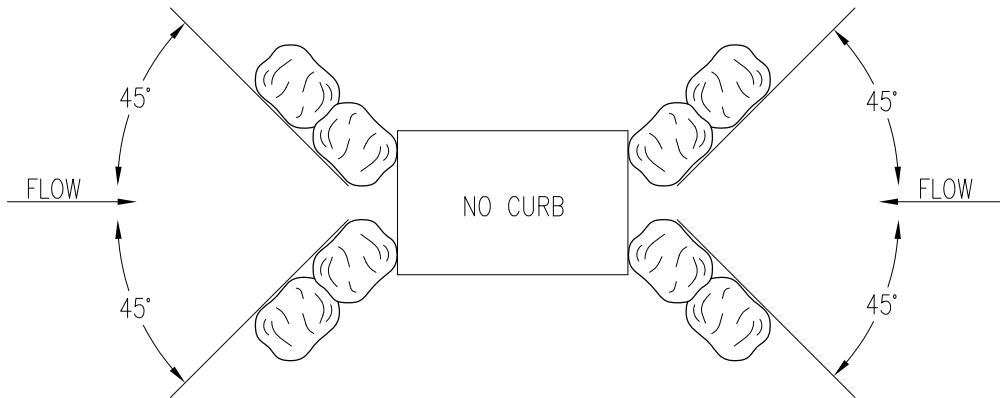

NOTES:

- 1.- SEDIMENT TRAPPED UPSTREAM OF SEDIMENT CONTROL BMP SHALL BE REMOVED WEEKLY AND PRIOR TO A RAINFALL EVENT.
- 2.- PLACE BMP'S TIGHTLY TOGETHER AT JOINTS TO PREVENT OR MINIMIZE SEEPAGE AT JOINTS.
- 3.- INLET SEDIMENT CONTROL MUST BE INSPECTED WEEKLY AND AFTER EACH STORM, AND REPAIRED OR REPLACED AS NEEDED.
- 4.- INLET SEDIMENT CONTROL IS REQUIRED FOR ALL DI'S IN ADDITION TO A STORM DRAIN INLET FILTER BAG.

REV.	DATE	DESCRIPTION
△		
△		
△		

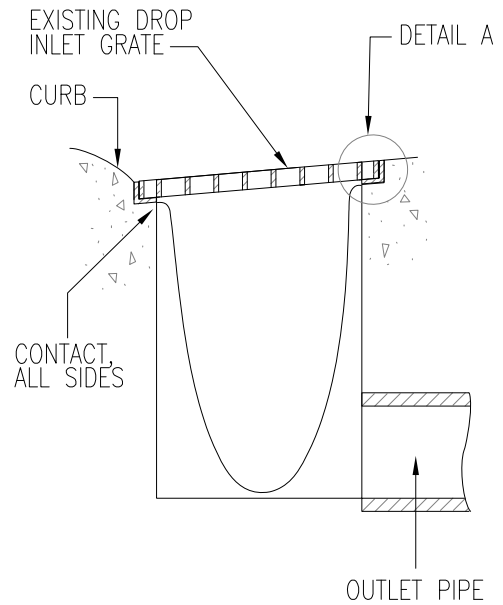
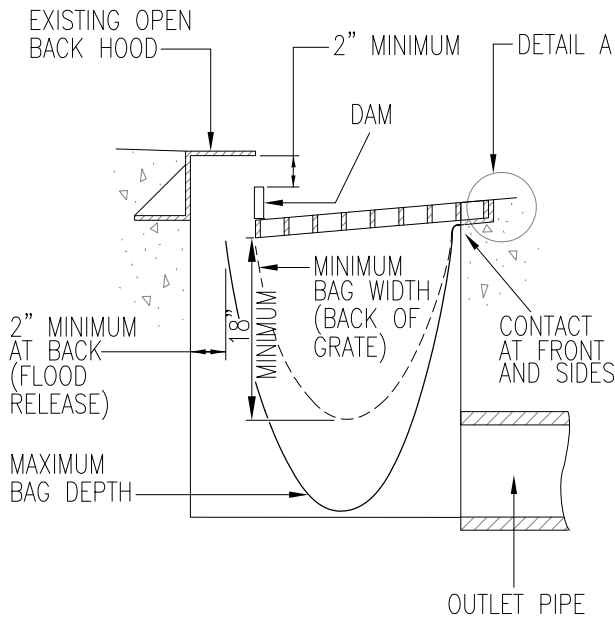

NOTES:

- 1.-THE MAXIMUM DRAINAGE AREA PER FILTER SHALL BE NO MORE THAN 2 ACRES.
- 2.-THE FILTER BAG SHALL BE MANUFACTURED FROM UV RESISTANT POLYPROPYLENE, NYLON, POLYESTER, OR ETHYLENE FABRIC WITH A MINIMUM TENSILE STRENGTH OF 50 LBS PER LINEAL FOOT, AN EQUIVALENT OPENING SIZE NOT GREATER THAN 20 SIEVE AND WITH A MINIMUM FLOW RATE OF 40 GALLONS/MINUTE/SQ FT.
- 3.-THE FILTER BAG MAY BE SUSPENDED FROM OR HELD IN PLACE BY THE EXISTING INLET GRATE (OR OTHER APPROVED METHOD), PROVIDING NO MODIFICATION OR DAMAGE SHALL BE DONE TO THE INLET GRATE OR FRAME. THE INLET GRATE SHALL NOT BE CAUSED TO REST MORE THAN 0.5\"/>
- 4.-THE FILTER BAG MAY EXTEND TO THE BOTTOM OF THE INLET BOX PROVIDED THE OUTLET PIPE IS UNOBSTRUCTED.
- 5.-FLOWS SHALL NOT BE ALLOWED TO BYPASS THE BAG. THE BAG OR ITS FRAME SHALL CATCH FLOWS AT ALL SIDES OF THE INLET, EXCEPT AS SHOWN FOR FLOOD RELEASE.
- 6.-INLET FILTER BAGS SHALL BE INSPECTED WEEKLY AND AFTER EACH RAINFALL DURING THE WET SEASON AND MONTHLY DURING THE DRY SEASON. SEDIMENT AND DEBRIS SHALL BE REMOVED BEFORE ACCUMULATIONS HAVE REACHED ONE THIRD THE DEPTH OF THE BAG. BAGS SHALL BE REPAIRED OR REPLACED AS SOON AS DAMAGE OCCURS.
- 7.-THIS DETAIL IS SCHEMATIC AND MUST BE ADJUSTED FOR DIFFERENT DI TYPES.

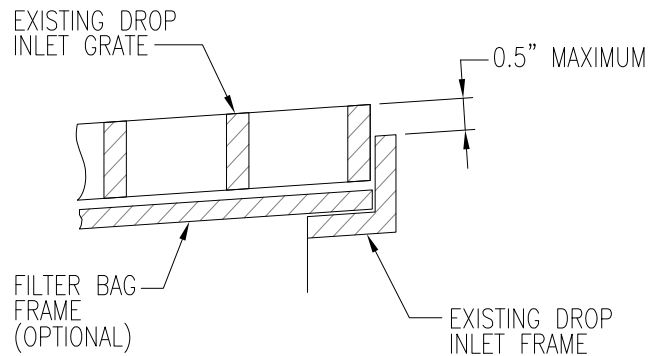

DETAIL A

REV.	DATE	DESCRIPTION
△		
△		
△		

VERTICAL SPACING MEASURED
ALONG THE FACE OF THE SLOPE
VARIES BETWEEN 8 FT.-20 FT.

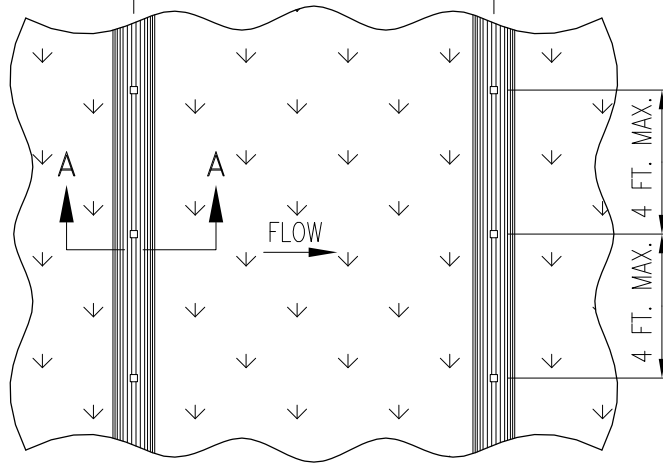

TYPICAL FIBER ROLL INSTALLATION

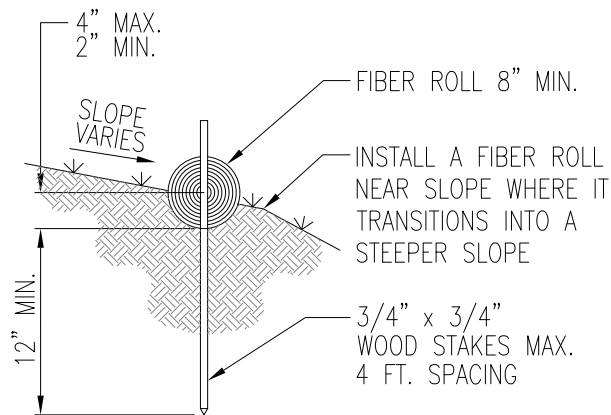

SECTION A - A

NOTES:

- 1.- INSTALL FIBER ROLLS IN A ROW ALONG A LEVEL CONTOUR.
- 2.- AT ENDS OF A ROW TURN THE LAST TWO FEET UP SLOPE SLIGHTLY.
- 3.- FIBER ROLLS SHALL BE BUTTED TIGHTLY AT THE JOINTS.
- 4.- DO NOT OVERLAP JOINTS.
- 5.- FIBER ROLLS SHALL BE INSPECTED WEEKLY AND AFTER STORMS, AND REPAINTED OR REPLACED AS NEEDED.

REV.	DATE	DESCRIPTION
△		
△		
△		

CITY OF SACRAMENTO
DEPARTMENT OF UTILITIES

**FIBER
ROLLS**

APPR'D BY:  NO SCALE
DATE: 3/12/20 DWG. NO. **Q-40**

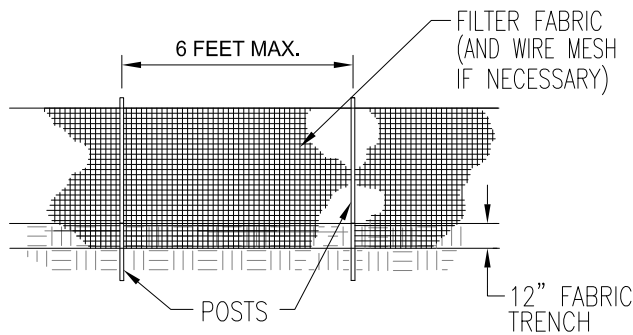

FRONT VIEW

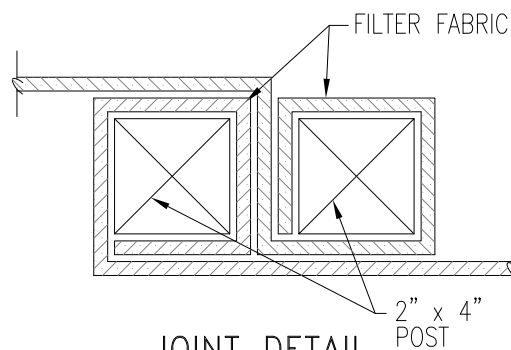

JOINT DETAIL

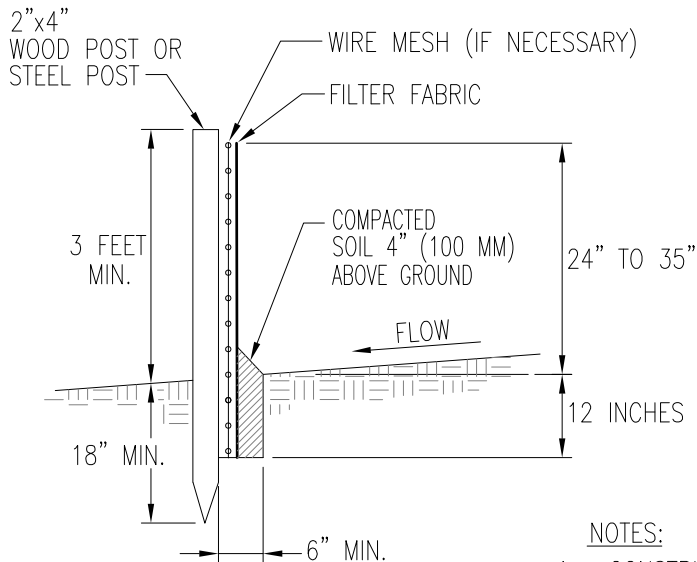

SECTION A-A

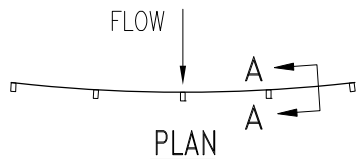

PLAN

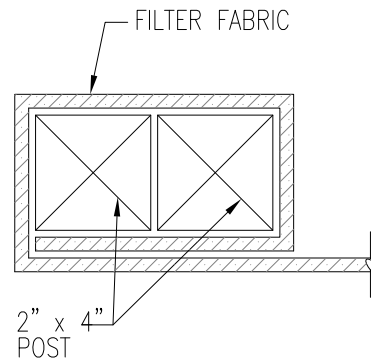

END STAKE DETAIL

NOTES:

- 1.- CONSTRUCT THE LENGTH OF EACH REACH SO THAT THE CHANGE IN BASE ELEVATION ALONG THE REACH DOES NOT EXCEED 1/3 THE HEIGHT OF THE LINEAR BARRIER. IN NO CASE SHALL THE REACH LENGTH EXCEED 150M.
- 2.- THE LAST 8 FT. OF FENCE SHALL BE TURNED UP SLOPE.
- 3.- OVERLAP STAKES, AND FOLD FENCE FABRIC TO AROUND EACH STAKE ONE FULL TURN.
- 4.- FOR END STAKE CONDITION FOLD FENCE FABRIC AROUND (2) STAKES (1) FULL TURN AND SECURE WITH (4) STAPLES.

NOTES:

1. SILT FENCE SHALL BE CONSTRUCTED LONG ENOUGH TO EXTEND ACROSS THE EXPECTED FLOW PATH.
2. FILTER FABRIC SHALL BE PROPYLENE, NYLON, POLYESTER OR ETHYLENE YARN WITH A MINIMUM TENSILE STRENGTH OF 50 LBS. PER LINEAR FOOT AT 20 PERCENT MAXIMUM ELONGATION AND CONTAINING ULTRAVIOLET INHIBITORS. FILTER FABRIC SHALL RETAIN A MINIMUM OF 85% OF THE SOIL, BY WEIGHT, BASED ON SIEVE ANALYSIS, BUT IS NOT FINER THAN AN EQUIVALENT OPENING SIZE OF 70. WHEN STANDARD STRENGTH FABRIC IS USED, A WIRE MESH SUPPORT SHALL BE SECURELY FASTENED TO THE UPSLOPE SIDE OF POSTS.
3. SUPPORT POSTS SHALL BE A MINIMUM 3.5' LONG 2"x4" WOOD POSTS OR 'T' SECTION FENCE POSTS DRIVEN A MINIMUM OF 18 INCHES INTO THE GROUND. POSTS SHALL BE SPACED A MAXIMUM OF 6 FEET APART. FABRIC SHALL BE SECURELY FASTENED TO POSTS WITH 1 INCH STAPLES OR 16 GAUGE WIRE TIES SPACED A MAXIMUM OF 6 INCHES APART.
4. A 12 INCH FABRIC TRENCH SHALL BE EXCAVATED ALONG THE UPHILL SIDE OF SILT FENCE POSTS. THE BOTTOM EDGE OF THE FABRIC SHALL EXTEND TO AND ACROSS THE BOTTOM OF THE TRENCH. THE TRENCH SHALL BE BACKFILLED TO 4 INCHES ABOVE GROUND AND COMPACTED TO BURY AND SECURE THE BOTTOM OF THE FILTER FABRIC.
5. CONTRACTOR SHALL MAKE INSPECTIONS WEEKLY DURING THE WET SEASON, MONTHLY DURING THE DRY SEASON AND IMMEDIATELY AFTER EACH RAINFALL TO DETERMINE IF REPAIRS AND SEDIMENT REMOVAL IS REQUIRED. SEDIMENT SHALL BE REMOVED BEFORE IT HAS REACHED ONE THIRD THE HEIGHT OF THE FILTER FABRIC.

REV.	DATE	DESCRIPTION
△		
△		
△		

CITY OF SACRAMENTO
DEPARTMENT OF UTILITIES

SILT FENCE-36"

APPR'D BY:  NO SCALE
DATE: 3/12/20 DWG. NO. **Q-50**

R: \Utilists\New_Std_Details\Wtr_Quality_Details\Q-50

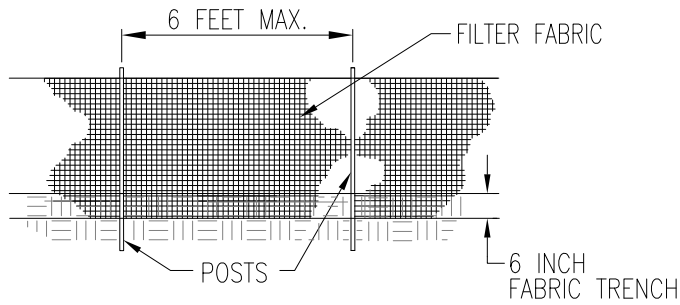

FRONT VIEW

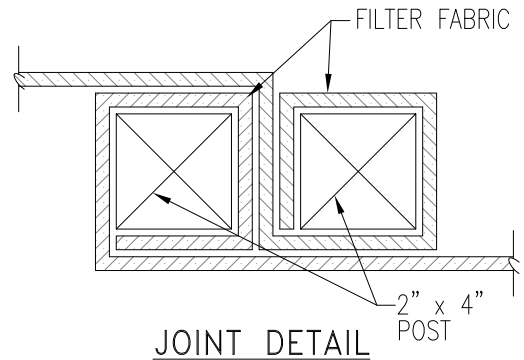

JOINT DETAIL

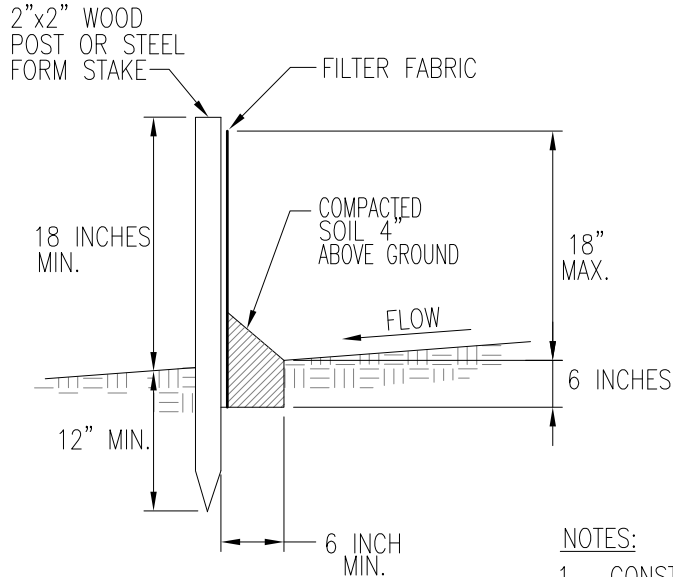

SECTION A-A

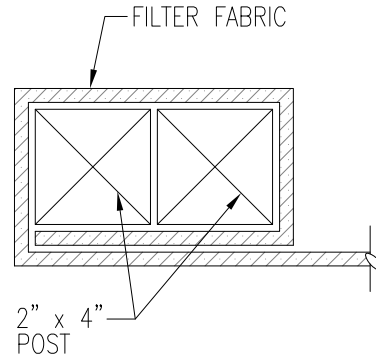

END STAKE DETAIL

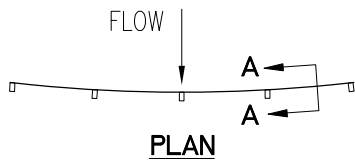

NOTES:

- 1.- CONSTRUCT THE LENGTH OF EACH REACH SO THAT THE CHANGE IN BASE ELEVATION ALONG THE REACH DOES NOT EXCEED 1/3 THE HEIGHT OF THE LINEAR BARRIER. IN NO CASE SHALL THE REACH LENGTH EXCEED 150M.
- 2.- THE LAST 8 FT. OF FENCE SHALL BE TURNED UP SLOPE.
- 3.- OVERLAP STAKES, AND FOLD FENCE FABRIC TO AROUND EACH STAKE ONE FULL TURN.
- 4.- FOR END STAKE CONDITION FOLD FENCE FABRIC AROUND (2) STAKES (1) FULL TURN AND SECURE WITH (4) STAPLES.

NOTES:

1. SILT FENCE SHALL BE CONSTRUCTED LONG ENOUGH TO EXTEND ACROSS THE EXPECTED FLOW PATH.
2. FILTER FABRIC SHALL BE PROPYLENE, NYLON, POLYESTER OR ETHYLENE YARN WITH A MINIMUM TENSILE STRENGTH OF 50 LBS. PER LINEAR FOOT AT 20 PERCENT MAXIMUM ELONGATION AND CONTAINING ULTRAVIOLET INHIBITORS. FILTER FABRIC SHALL RETAIN A MINIMUM OF 85% OF THE SOIL, BY WEIGHT, BASED ON SIEVE ANALYSIS, BUT IS NOT FINER THAN AN EQUIVALENT OPENING SIZE OF 70. WHEN STANDARD STRENGTH FABRIC IS USED, A WIRE MESH SUPPORT SHALL BE SECURELY FASTENED TO THE UPSLOPE SIDE OF POSTS.
3. SUPPORT POSTS SHALL BE A MINIMUM 24" LONG 2"x2" (50) WOOD POSTS OR 'T' SECTION FENCE POSTS DRIVEN A MINIMUM OF 12 INCHES INTO THE GROUND. POSTS SHALL BE SPACED A MAXIMUM OF 6 FEET APART. FABRIC SHALL BE SECURELY FASTENED TO POSTS WITH 1 INCH STAPLES OR 16 GAUGE WIRE TIES SPACED A MAXIMUM OF 6 INCHES APART.
4. A 6 INCH FABRIC TRENCH SHALL BE EXCAVATED ALONG THE UPHILL SIDE OF SILT FENCE POSTS. THE BOTTOM EDGE OF THE FABRIC SHALL EXTEND TO AND ACROSS THE BOTTOM OF THE TRENCH. THE TRENCH SHALL BE BACKFILLED TO 4 INCHES ABOVE GROUND AND COMPACTED TO BURY AND SECURE THE BOTTOM OF THE FILTER FABRIC.
5. CONTRACTOR SHALL MAKE INSPECTIONS WEEKLY DURING THE WET SEASON, MONTHLY DURING THE DRY SEASON AND IMMEDIATELY AFTER EACH RAINFALL TO DETERMINE IF REPAIRS AND SEDIMENT REMOVAL IS REQUIRED. SEDIMENT SHALL BE REMOVED BEFORE IT HAS REACHED ONE THIRD THE HEIGHT OF THE FILTER FABRIC.

REV.	DATE	DESCRIPTION
△		
△		
△		

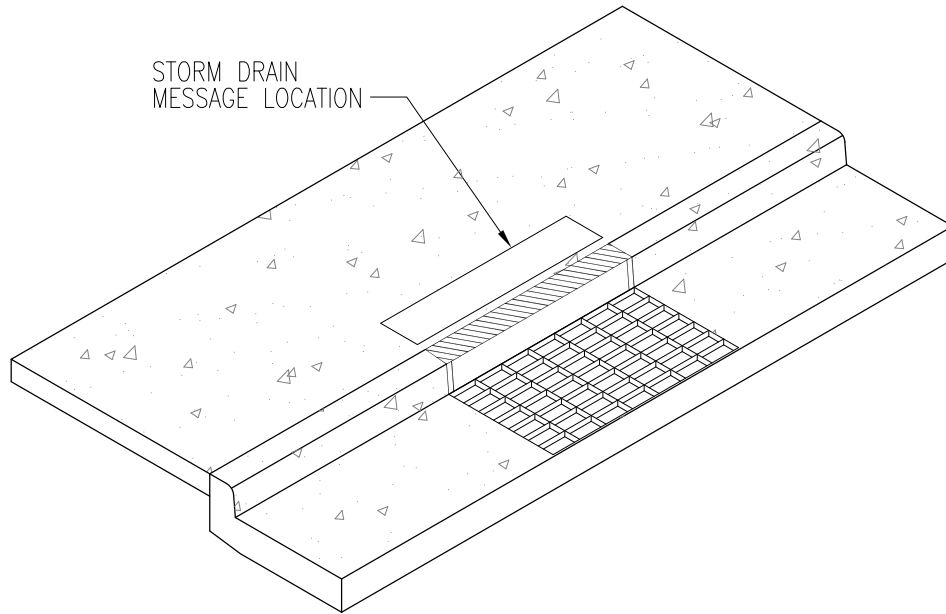

NO DUMPING!
FLOWS TO RIVER 

NO DUMPING!
FLOWS TO CREEK 

NO DUMPING!  **I LIVE**
DUMPING! **DOWNSTREAM**

NOTES:

1. STORM DRAIN MESSAGE SHALL BE APPLIED IN SUCH A WAY AS TO PROVIDE A CLEAR, LEGIBLE IMAGE.
2. STORM DRAIN MESSAGE SHALL BE PERMANENTLY APPLIED DURING THE CONSTRUCTION OF THE CURB AND GUTTER USING A METHOD APPROVED BY THE LOCAL AGENCY.
3. FOR AREA DRAIN INLETS, STORM DRAIN MESSAGE SHALL BE PLACED ADJACENT AND PARALLEL TO THE LONG AXIS OF THE DRAIN.
4. LETTERS SHALL BE 1-1/2" IN HEIGHT. DIMENSIONS OF STORM DRAIN MESSAGE SHALL NOT EXCEED 12"x33".
5. IF THE MESSAGE IS STAMPED IN CONCRETE, THE DEPTH SHOULD BE APPROXIMATELY 0.25".
6. IF AN ALTERNATIVE STORM DRAIN MESSAGE IS PROPOSED, IT SHALL BE APPROVED BY THE LOCAL AGENCY.

REV.	DATE	DESCRIPTION
△		
△		
△		

CITY OF SACRAMENTO
 DEPARTMENT OF UTILITIES

**STORM DRAIN
 MESSAGE LAYOUT**

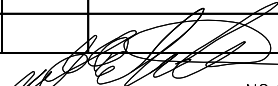
APPR'D BY: 
 DATE: 3/12/20 DWG. NO. **Q-70**
 NO SCALE

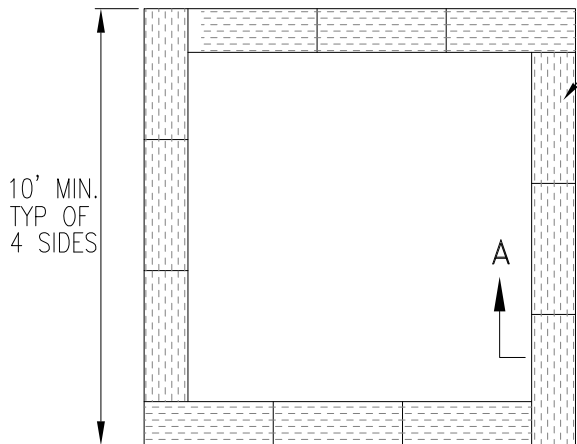

BALE CONFIGURATION

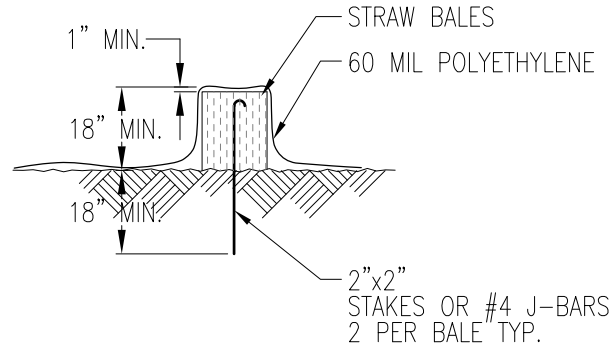

SECTION A-A

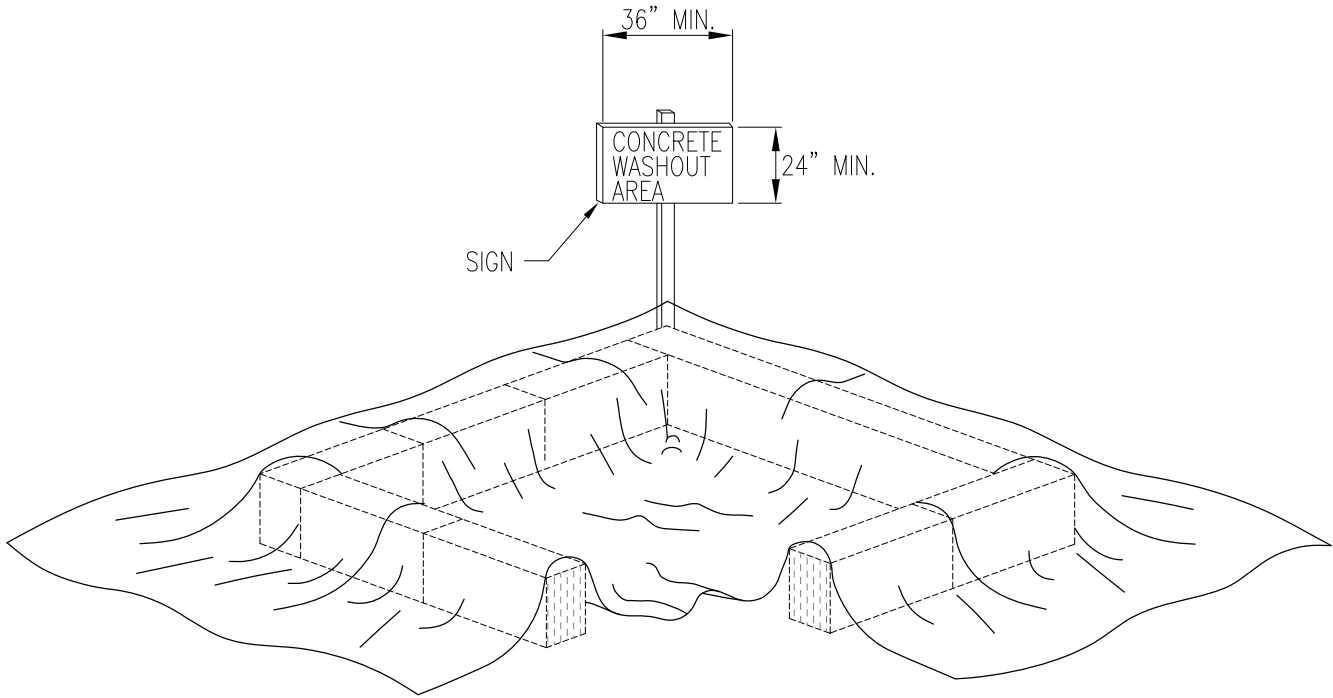

THIS SECTION REMOVED FOR GRAPHICAL REPRESENTATION ONLY. STRAW BALE PERIMETER SHALL BE CONTINUOUS.

NOTES:

- 1.- FACE SIGN TOWARD NEAREST STREET OR ACCESS POINT
- 2.- CONCRETE WASHOUT SHALL BE LOCATED BEHIND CURB AND 50 FT. MINIMUM FROM DRAINAGE INLETS OR WATERCOURSES

REV.	DATE	DESCRIPTION
△		
△		
△		

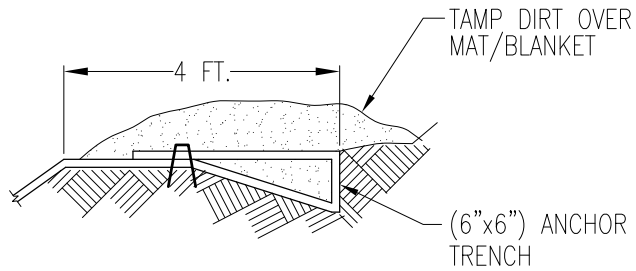

ANCHOR DETAIL

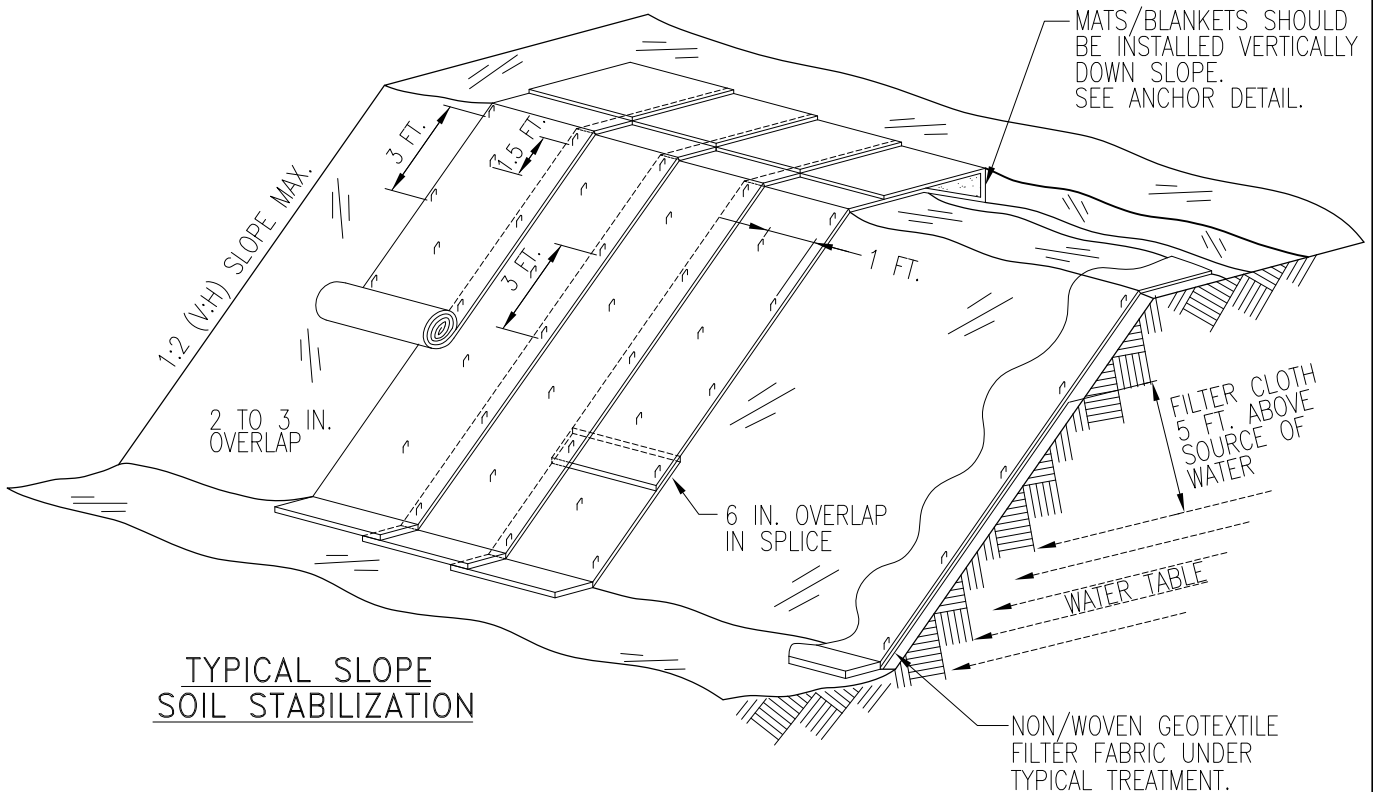

TYPICAL SLOPE
SOIL STABILIZATION

WET SLOPE LINING

NOTES:

- 1.-SLOPE SURFACE SHALL BE FREE OF ROCKS, CLODS, STICKS AND GRASS. MATS/BLANKETS SHALL HAVE GOOD SOIL CONTACT.
- 2.-LAY BLANKETS LOOSELY AND STAKE OR STAPLE TO MAINTAIN DIRECT CONTACT WITH THE SOIL. DO NOT STRETCH.
- 3.-INSTALL PER MANUFACTURER'S RECOMMENDATIONS.

REV.	DATE	DESCRIPTION
△		
△		
△		