

Oak Park Residential and Commercial Design Standards and Guidelines



Oak Park Redevelopment Area and Design Review District



JANUARY 2007

Table of Contents

Introduction	1
Purpose of the Design Standards and Guidelines	1
The City’s Commitment to Sustainability	2
How to Use the Design Standards and Guidelines	2
Design Review Process	3
Location of the Oak Park Redevelopment Area and Design Review District	4
Residential and Commercial Character Areas	5
Residential Design Standards and Guidelines	7
Residential History and Neighborhood Context	8
Residential Character Area	9
SINGLE-FAMILY RESIDENTIAL	11
Site Design	12
1 Setbacks and Orientation	13
2 Scale and Mass	14
3 Number of Stories	16
4 Garages	17
5 Parking	19
Architecture	20
6 Architectural Character and Detailing	21
7 Roof Styles	22
8 Entry Features	24
9 Doors	25
10 Windows	26
11 Siding	27
12 Roofing	28
13 Lighting and Addresses	30

Table of Contents

Site Elements	31
14 Landscaping	32
15 Irrigation.	34
16 Fencing	35
17 Paving/Hardscaping Surfaces	36
18 Utilities and Storage Facilities	37
19 Access Ramps	38
MULTI-FAMILY RESIDENTIAL.	39
Site Design	40
20 Relationship to the Street.	41
21 Setbacks	42
22 Interior Common Spaces	43
23 Scale and Mass	44
24 Location of Parking Lots	45
Architectural Elements	46
25 Garages.	47
26 Entry Features	48
27 Lighting	49
28 Signage and Addresses.	50
Site Elements	51
29 Landscaping	52
30 Irrigation.	54
31 Fencing	55
32 Paving/Hardscaping Surfaces	56
33 Services and Utilities	57
MANUFACTURED HOMES	59
34 Setbacks, Garages, and Parking	61
35 Creating an Attractive Streetside Facade.	62
36 Applying Site-Built Home Standards to Roof Design	63
37 Giving an Appearance of Permanency	64
38 Selecting Suitable Materials.	65
Commercial Design Standards and Guidelines	67
Broadway Commercial Character Area	68
Stockton Commercial Character Area	70

Table of Contents

Site Design	72
39 Building Orientation, Setbacks, and Build-to Lines	73
40 Parking	74
Architectural Elements	76
41 Building Height, Massing, and Scale	77
42 Building Facades	78
43 Additions	82
44 Roof Forms	83
45 Entry Features	84
46 Windows and Doors	85
47 Color	87
48 Materials	88
49 Canopies, Awnings, and Arcades	90
50 Signage and Graphics	92
51 Lighting	94
52 Services and Utilities	96
Streetscape Guidelines	98
53 Parking Lot Design	99
54 Street Trees	101
55 Landscape Elements	102
56 Hardscape Elements and Street Furniture	103
Appendices	105
Appendix A — Additional Resources	106
Appendix B — Predominant Residential Architectural Styles	108
Appendix C — Commercial Architectural Styles	115
Appendix D — U.S. Secretary of the Interior’s Standards for Rehabilitation of Historic Buildings	120
Appendix E — Sustainability Through High Performance Building Design	121
Appendix F — Glossary of Terms	123

Table of Contents

This Page Intentionally Left Blank

Introduction

PURPOSE OF THE DESIGN STANDARDS AND GUIDELINES

The Oak Park Residential and Commercial Design Standards and Guidelines (Design Standards and Guidelines) have been specifically developed for the Oak Park Redevelopment Area and Design Review District. They are intended to provide consistent design principles for residential and commercial structures that can contribute to the creation of neighborhoods with a strong, cohesive sense of place, and can improve the overall character of neighborhoods by making them more attractive, safe, and inviting places to live.

The Design Standards and Guidelines have been created for use by residents, developers, design professionals, City of Sacramento (City) planning staff, and various design review boards. They are intended to facilitate the design review process by helping applicants and City planning staff identify major design issues and devise solutions early in the application process. In summary, these Design Standards and Guidelines are intended to:

- create a positive sense of place and enhance community identity;
- promote neighborhood pride;
- encourage high-quality development and provide creative design solutions and options;
- provide clear and usable design direction to project applicants, developers, designers, and City planning staff;
- protect and enhance property values and community economic viability; and
- facilitate a clear and expeditious project review process.

Projects will be reviewed for compliance with the design principles identified in this document. Although it is understood that not all design principles will be applicable to all proposed projects, conformance with relevant principles is required.

Overall, the Design Standards and Guidelines are intended to encourage consistent design while allowing for variety and innovation. City staff do not advocate a particular architectural style or styles, and will review all applications on the basis of the guidelines in this document.

THE CITY'S COMMITMENT TO SUSTAINABILITY

In 2006, the Sacramento City Council adopted a vision for the city reflecting the Council's commitment to "sustainability and livability." Based on the Council's vision, the City continues to develop and refine standards and guidelines intended to influence the design of future development in Sacramento.

In the meantime, these Design Standards and Guidelines include a number of specific guidelines that address environmentally responsive site, building, and landscaping design. In addition, Appendix E provides additional resources and information.

HOW TO USE THE DESIGN STANDARDS AND GUIDELINES

Each subsection in the Design Standards and Guidelines is organized to include some or all of the following elements:

Design Principle

The *design principle* is a general concept that must be met by all projects and forms the basis for individual design guidelines.

Rationale

The *rationale* explains the key features of a design principle and how it relates to the neighborhood context.

General Design Standards and Guidelines

The *general Design Standards and Guidelines* provide a list of specific recommendations to ensure that a design principle is appropriately applied to project design.

Sustainability Design Guidelines

The *sustainability design guidelines* provide suggestions for high performance building and landscape design.

Residential and Commercial Character Area Design Guidelines

The *residential and commercial character area design guidelines* are additional guidelines that apply only in designated areas. The character areas are briefly described on pages 4 and 5 of this Introduction, with more complete descriptions in the Residential and Commercial sections.

Graphics

Drawings and photos provide visual support for the principles and guidelines.

DESIGN REVIEW PROCESS

City planning staff must review the design of any proposed infill project or major renovation of or addition to an existing structure within the Oak Park Redevelopment Area and Design Review District. City staff will then provide early notification to adjacent property owners and community groups of the proposed project. Applicants should expect to communicate with planning staff at several key junctures in the application process, including a pre-application meeting and a meeting following the review process to discuss any revisions. Once a project has been approved by City Design Review staff or the appropriate review board, as necessary, an application for a building permit may be submitted, provided that any other planning entitlements needed for the project have been approved.

LOCATION OF THE OAK PARK REDEVELOPMENT AREA AND DESIGN REVIEW DISTRICT

The Oak Park neighborhood is located within the City of Sacramento, east of State Route 99 and south of U.S. Highway 50, as shown in the map below, and on page 5.

Residents and business owners who wish to determine whether their property is within the Oak Park Design Review District may call the help line at (916) 808-5656, or view maps at the City's website at:

<http://www.cityofsacramento.org/dsd/maps/DesignReviewMaps.cfm>



RESIDENTIAL AND COMMERCIAL CHARACTER AREAS

Several older areas in Oak Park display unique characteristics, including internally similar architecture and local responses to site design. As shown in the map on the following page, three character areas have been identified for the purposes of these design guidelines:

- Oak Park Residential Character Area
- Broadway Commercial Character Area
- Stockton Commercial Character Area

Special character area design guidelines have been developed to protect the visual and aesthetic integrity of these long-established areas. Design review staff will review each project for conformance with the Oak Park Design Standards and Guidelines, including any special character area design guidelines.

In addition, when an applicant proposes renovations or additions to a building 50 years old or older, the structure may be subject to additional review to determine if it is potentially eligible as a historic resource. One of the following review processes may be relevant.

- An individual structure's potential eligibility as a historic resource will be considered during the environmental review portion of the design review process. If a structure is determined to be potentially eligible, additional research to definitively determine historic status may be carried out.
- A broader City survey may also be carried out to determine historic resources within a specified neighborhood or area.

Projects involving renovations or additions to buildings that have been designated as historic are subject to the U.S. Secretary of the Interior's *Standards for Rehabilitation and Guidelines for Rehabilitating Historic Buildings* (Standards), which have been adopted by the City in addition to these Design Standards and Guidelines.

The majority of older structures in Oak Park are unlikely to be designated as historic. However, many still display sufficient architectural interest to warrant careful attention to renovations and/or additions that might modify the original structure. Design review staff will carefully review each application on a case-by-case basis to determine the relevance of the U.S. Secretary of the Interior's Rehabilitation Standards, which have been included for informational purposes as Appendix D in this document.

**OAK PARK REDEVELOPMENT AREA WITH
RESIDENTIAL AND COMMERCIAL CHARACTER AREAS**

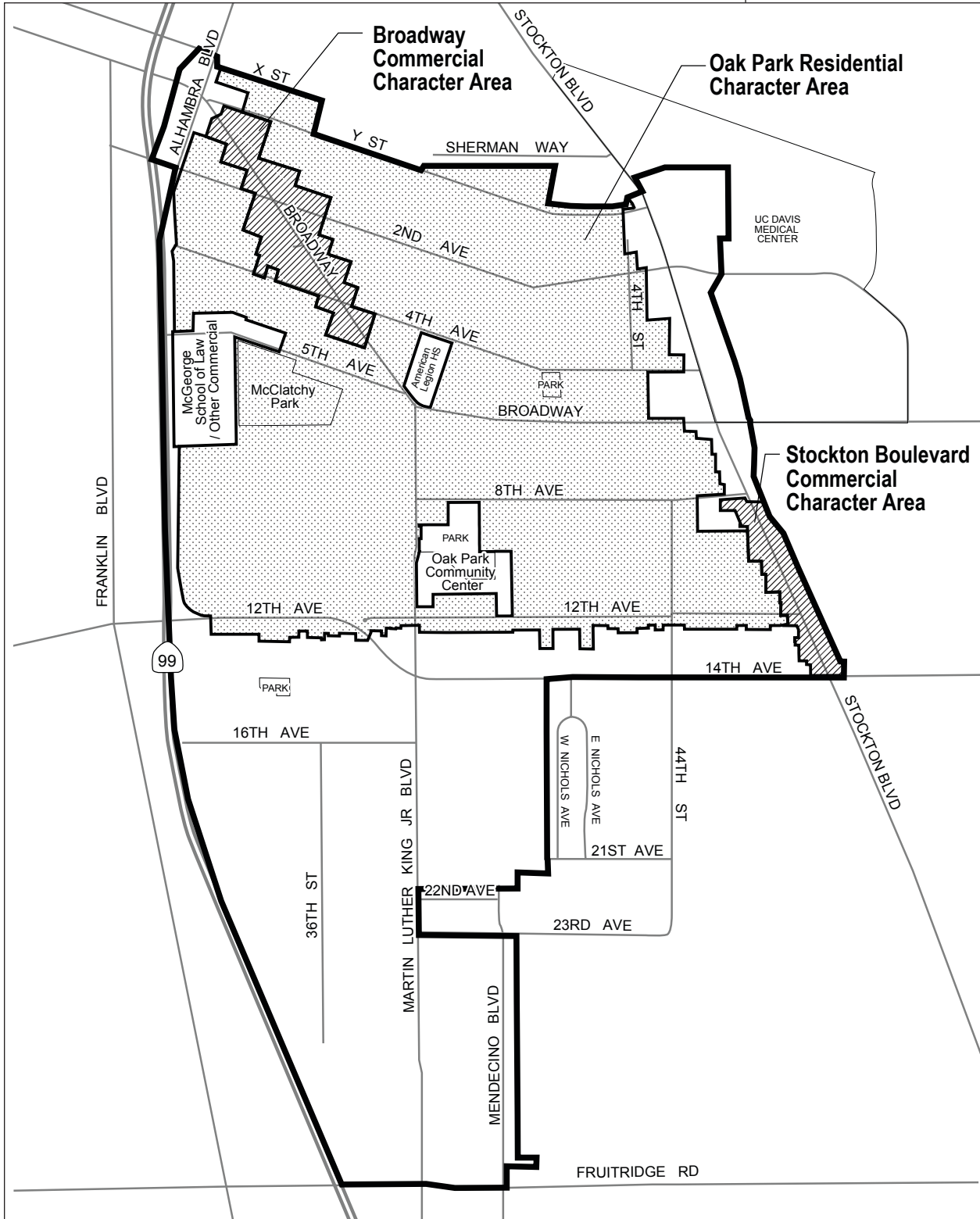

This Page Intentionally Left Blank

Residential Design Guidelines



Residential Design Standards and Guidelines

The Residential Design Standards and Guidelines are intended to be applied to all residential infill construction, as well as additions or renovations to existing dwellings. Separate sections in this document address the design of single-family, multi-family, and manufactured homes. In addition, the northern portion of Oak Park has been designated as the Oak Park Residential Character Area (Residential Character Area) described on page 9.

Oak Park is a long-established neighborhood with an ongoing pattern of infill construction resulting in a diverse and interesting residential neighborhood fabric. However, this variety of residential structures poses unique challenges for Oak Park applicants who wish to construct new infill homes or make renovations or additions to existing structures.

One recent trend in infill construction is market demand for moderately priced new homes in close proximity to the city center. These infill homes are often significantly larger than older existing homes. In addition, new construction methods and current architectural styles often differ from those of older, established homes, sometimes resulting in homes that are noticeably different in appearance from established homes.

Despite these challenges, it is essential that applicants balance contemporary construction methods and architectural styles with respect for the neighborhood's established scale, form, and patterns of existing development. Finding that balance lies in the continued creation of neighborhoods that are visually cohesive, yet variable and adaptable. These Design Standards and Guidelines are intended to provide principles and guidelines that support the established residential context while providing room for new infill that can enliven and revitalize neighborhoods.

Introduction

RESIDENTIAL HISTORY AND NEIGHBORHOOD CONTEXT

Now one of the most densely populated neighborhoods in Sacramento, Oak Park was originally developed as the city's first suburb in 1887, when a group of businessmen formed the Oak Park Association. The Oak Park Association administered the lay-out of 40-foot by 150-foot lots and constructed homes on them. The northern portion of Oak Park includes this original development which is a portion of the Residential Character Area.

Oak Park residential development that is not within the Residential Character Area represents development that spread progressively south of 12th Avenue throughout the first half of the 20th century. The styles of homes south of 12th Avenue are influenced by the architectural styles found in older parts of Oak Park, as well as newer 20th century styles, such as Minimal Traditional and Ranch. These homes are typically smaller, one-story dwellings. Many homes also have front- or side-facing gable or hip roofs and typically include a garage with entry from the front of the lot.

Newer infill homes throughout Oak Park reflect both traditional and contemporary influences. Many infill homes are two stories in response to the challenge of building larger homes on small lots. Stucco is a common exterior cladding material, although various forms of lap siding may also be seen.



This ranch-style home is typical of many homes south of 12th Avenue.



This infill home displays some of the characteristics seen in contemporary homes.

RESIDENTIAL CHARACTER AREA

The Residential Character Area is located north of, and including, 12th Avenue (see the map on the following page for specific boundaries). The homes within the Residential Character Area represent a variety of architectural styles including Victorian, Queen Anne, Craftsman, Bungalow, Sacramento highwater, Oak Park vernacular, and various period revival styles. (The more common architectural styles are shown in Appendix B of this document.) Although a few streets represent a mixture of styles, many blocks and streets have some consistency of style and materials, representing the numerous small subdivisions constructed by the firms working in the area at the time.

Of the many styles represented, Craftsman influences are perhaps the most common. Craftsman homes tend to be one or one-and-a-half stories, with gable roofs, and front porches with sturdy, square support columns. Common building materials include wood and brick.

Flooding was frequent in Sacramento during the late 19th and early 20th centuries, and many of the homes built during that time period have high foundations, with the main story a half floor above the ground level. These homes are known as Sacramento highwater homes, and can generally be found in Victorian and Bungalow styles.

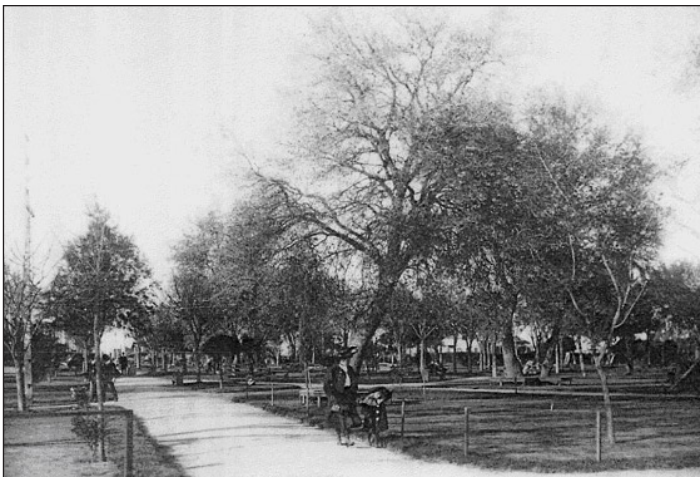

A woman and child stroll in Joyland (now McClatchy Park) in this early 20th century photo.



This bungalow in the Residential Character Area shows Craftsman influences.



This home in the Residential Character Area displays period revival influences.



Sacramento highwater homes typically have an elevated main story.

Introduction

RESIDENTIAL CHARACTER AREA MAP

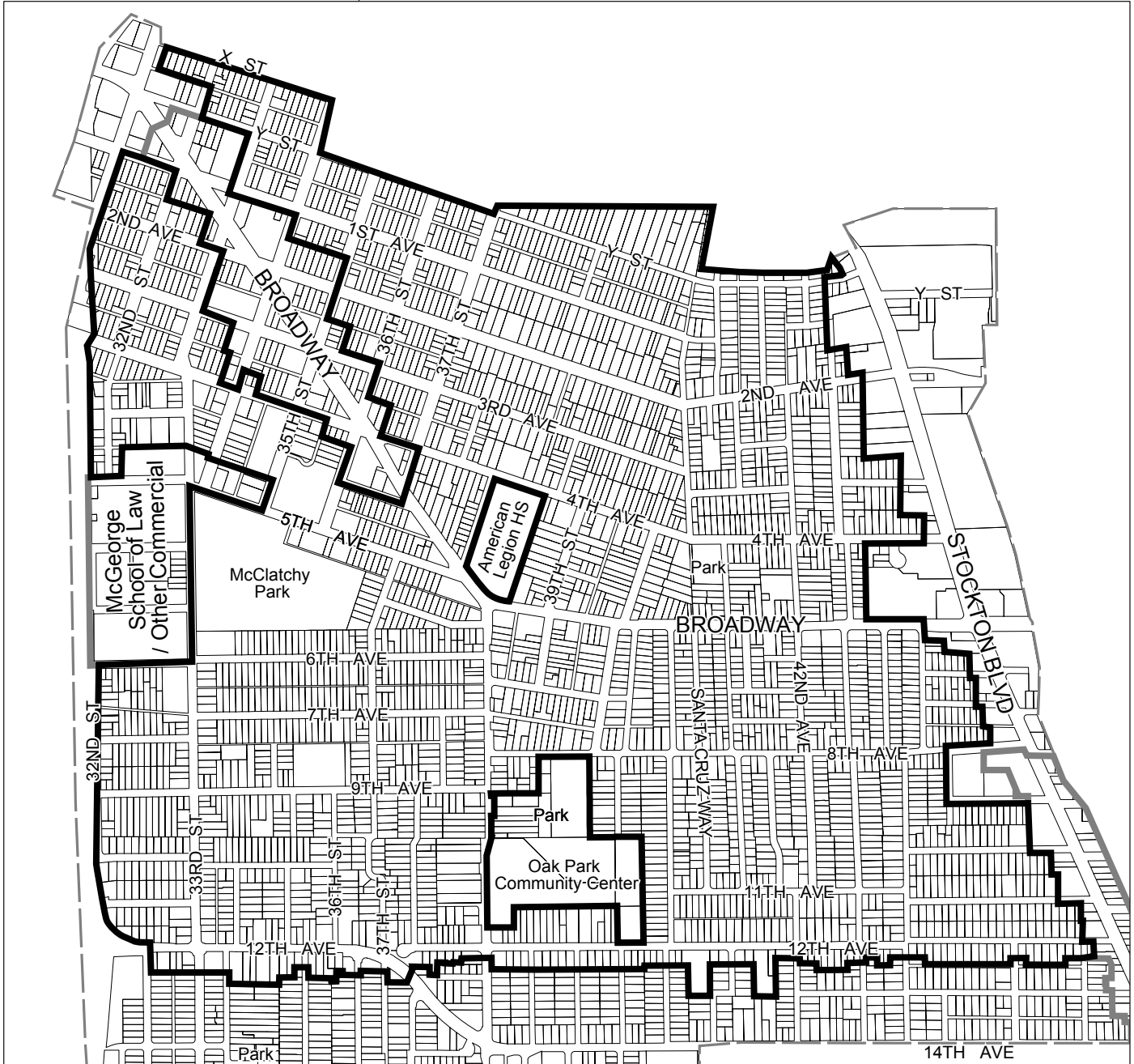

Single-family Residential

There are many ways to design a good home. The City Development Services Department has pre-approved home plans that can aid the new home builder and reduce application time, and these plans do not exhaust the many possible design options.

The home shown below displays some of the key characteristics that are recommended in the Design Standards and Guidelines, and how these design features might be applied to all residential infill, additions, and renovations. This sample home is intended as an example only, since the Guidelines are sufficiently flexible to allow for many variations in home styles and design. Additional guidelines for the Residential Character Area are relevant for that area only.

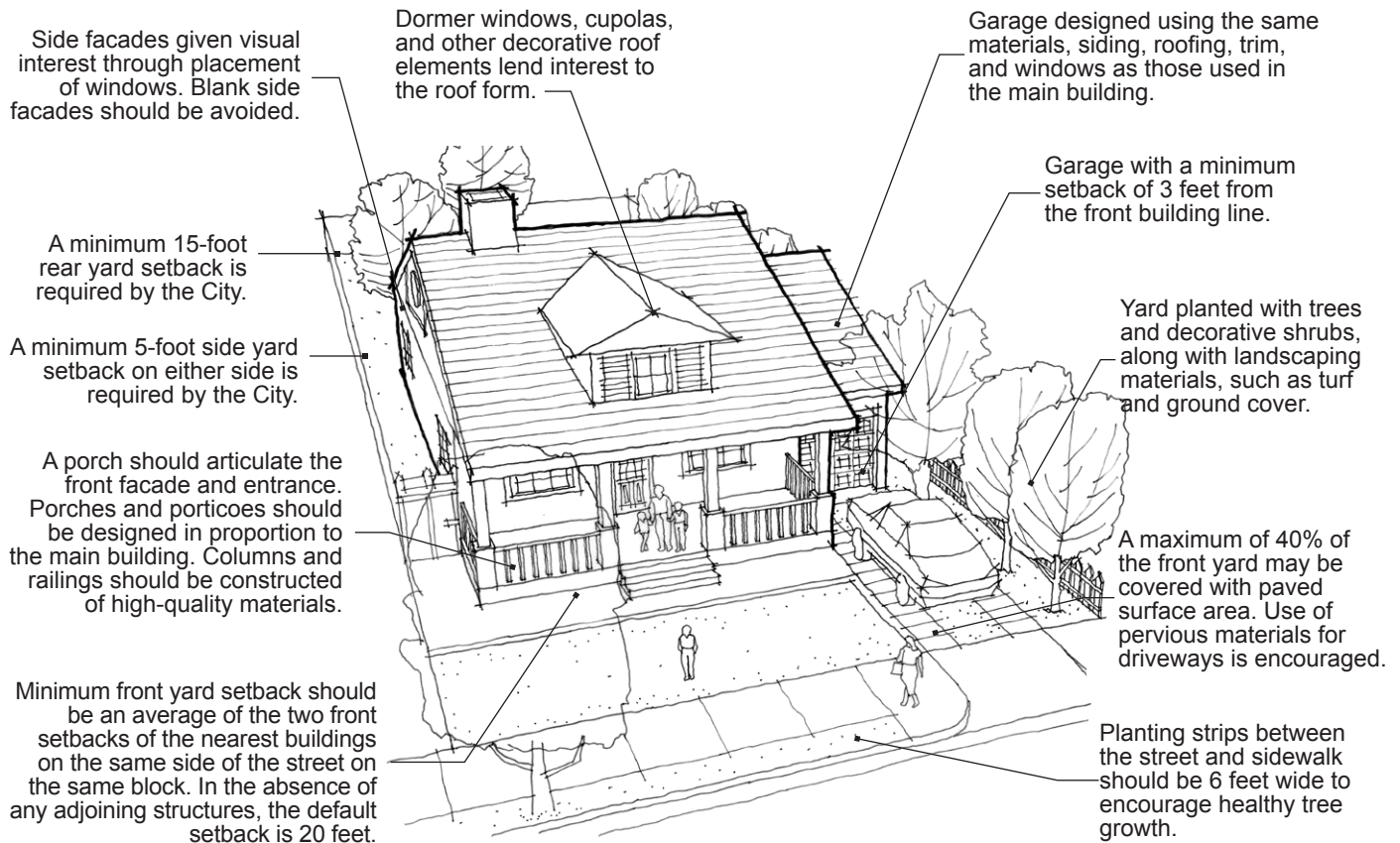

Single-family Residential Home with Required and Recommended Design Features

SITE DESIGN

Site design addresses a home's location on the lot, its orientation toward the street and adjacent buildings, and its overall layout relative to the site. The site design of infill homes and additions to existing homes should emphasize respect for the context of established structures. In addition, infill homes and some additions, where appropriate, should:

- reflect the scale of existing homes on the block;
- in most cases, be located toward the front of the lot;
- provide an entry facing the street to create a welcoming appearance and to give homes “curb appeal”;
- minimize the appearance of the garage by locating it at the side or rear of the home; and
- minimize the appearance of mass in two-story homes with an articulated facade.

Single-family Residential

1 Setbacks and Orientation

Design Principle

The front setback and the placement of the home on the lot shall correspond to the prevailing setbacks of other homes on the block to create a consistent appearance along the street.

Rationale

Setbacks may be slightly varied to create interest, but should contribute to the established assemblage of homes on the block. Front yard setbacks should also meet City standards where possible. However, homes in the Residential Character Area often have front setbacks that are smaller than those required by the City. Where this occurs, front setbacks for new infill development should be an average of the existing setbacks on the block.

General Design Standards and Guidelines

- 1-1 Homes should be oriented toward the front of the lot with front entries facing the street to encourage an active visual relationship with the street.
- 1-2 Infill construction should generally be parallel to lot lines.
- 1-3 The front setback of a home should be an average of the setbacks of the other homes on the block.
- 1-4 Infill structures should reinforce the existing rhythm of building widths and side setbacks.

Sustainability Guidelines

- 1-5 Homes should be designed and oriented on the lot to maximize solar access on southern exposures so that such features as photovoltaic solar panels and daylighting can be incorporated into the design of the home, when feasible.



This setback is typical of newer infill homes that meet City front yard setback standards.



This streetscape shows an example of front yard setbacks in the Residential Character Area that are smaller than current City standards.

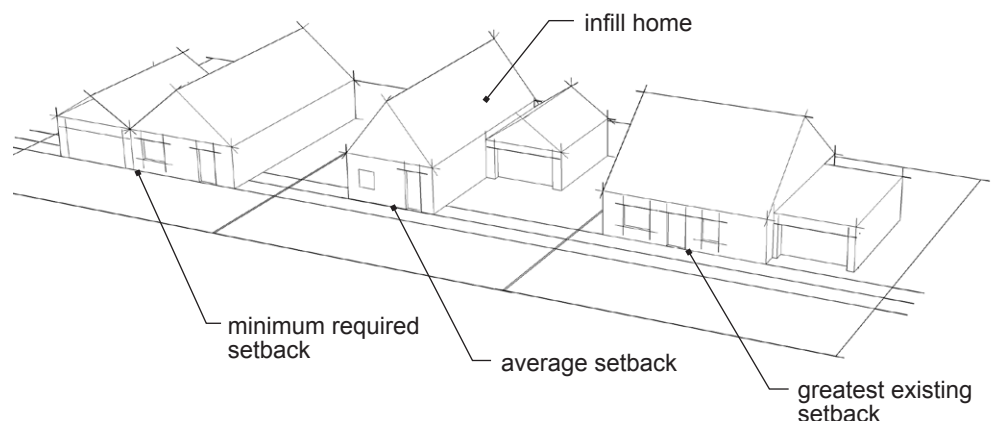

Homes should be built to the average front setback, where appropriate.

Single-family Residential

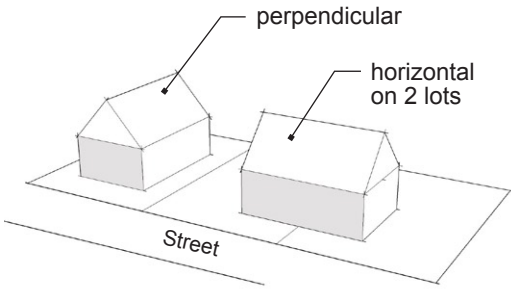

Orient homes on small lots perpendicular to the street. These buildings have identical square footage, but the home on the left appears smaller because it is perpendicular to the street.



The facade of this home has been broken down into smaller components to reduce the appearance of mass.

2 Scale and Mass

Design Principle

An infill home shall be compatible with the overall scale and mass of other homes on the block. An addition to an existing home shall be compatible with the scale and mass of the existing home, as well as with the scale and mass of other homes on the block.

Rationale

Although new infill homes and additions to existing homes are addressing demand for more square footage, they also should respect earlier, established homes by minimizing the appearance of bulk and mass through site layout and architectural design.

General Design Standards and Guidelines for Infill Construction

- 2-1 Homes on long, narrow lots should be oriented perpendicular to the street to minimize the appearance of mass.
- 2-2 The mass of a larger structure should be broken down into smaller components that are similar in scale to other buildings in the neighborhood.
- 2-3 The garage should be located a minimum of 3 feet behind the front facade of the home (the main front wall) to minimize the appearance of mass (also see Section 4, Garages).

General Design Standards and Guidelines for Additions

- 2-4 Additions should respect the massing, scale, and height of the primary structure.
- 2-5 Additions should not visually interfere with the original structure.
- 2-6 Additions that are taller than the original building should be located at the rear of the building so that the new addition does not visually overpower the original structure.

Single-family Residential

- 2-7 Large additions should be broken down into smaller, varied components that relate to the scale and massing of the original structure.
- 2-8 Contemporary homes are typically constructed as concrete slab-on-grade. When infill homes are constructed in areas where older homes are raised above grade, the concrete slab of the newer home should be treated in one or more of the following ways:
- The height of the slab could be increased.
 - The soil under the slab could be graded so that it is above the grade of the surrounding yard.
 - The home could be constructed with a raised wooden subfloor. In this case, the home could also have a raised entry that steps down to the ground level.
- 2-9 When constructing an addition beneath a home, the home should be excavated rather than raised. Visual impacts on the home should be minimized, with the design of the raised portion compatible in scale and character to the original structure.

Residential Character Area Guidelines

- 2-10 Additions and renovations should be designed to retain the original form, materials, and characteristics of the original structure.
- 2-11 An addition should be subordinate to the original structure and designed to minimize its visibility from the street side.

Sustainability Guidelines

- 2-12 Solar access for daylighting and solar panels should be considered in massing design. Glazing should be located predominantly on the north and south sides of the home. Glazing on the west side of the home should be minimized, unless the west side of the structure is the street side.

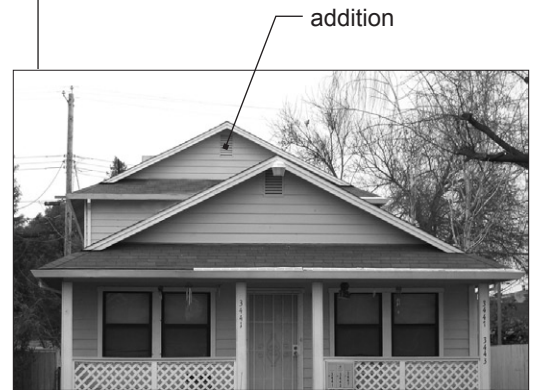

Additions should be located at the rear so as not to overpower the original structure.

Single-family Residential

3 Number of Stories

Design Principle

Two-story homes are acceptable in areas where one-story homes predominate, but they shall be designed to minimize the appearance of mass of the second story.

Rationale

Although there are many two-story homes in Oak Park, the majority of homes are one story. Because two-story infill structures have the capacity to appear out of scale with other homes on a block, they should be carefully designed so as not to overwhelm adjacent one-story homes.

General Design Standards and Guidelines

- 3-1 The front of the home should not present an unbroken two-story wall to the street. Facades should be articulated to break up the surface, add interest, and minimize the appearance of mass. Articulation should include at least two of the following features:
 - protruding or recessed facade surfaces
 - bow, bay, or dormer windows
 - horizontal elements such as cornices, window lintels, or horizontal bands
 - porches or porticoes
- 3-2 All sides of the homes should be given visual interest through the careful placement of windows, while also protecting the privacy of the adjacent home. No side of a two-story home should present an entirely blank facade.
- 3-3 Porches and porticoes in two-story homes should be one story to maintain the proportion and context of the surrounding homes on the block (see Category 8, "Entry Features").
- 3-4 Architectural elements, such as dormers, multiple gables, and windows, should be added to the second story to impose articulation and break up the facade, where feasible.
- 3-5 Infill duplexes constructed on narrow lots (40 feet wide or less) should be designed as two-story stacked units. These structures should conform to the same principles outlined above, with articulation and the addition of architectural elements.



Architectural details and articulated facades can help to minimize the appearance of two-story infill homes.



Dormer windows and other decorative roof elements help to break up the mass of a two-story home.

Single-family Residential

4 Garages

Design Principle

The garage shall be placed at the side or rear of the primary residence to minimize its visibility from the street, and shall match its character and materials.

Rationale

To emphasize the front entryway and porch and minimize the prominence of the garage, the garage should be placed at the side or rear of the home, recessed behind the front facade.

General Design Standards and Guidelines

- 4-1 Garages shall conform to all relevant City of Sacramento regulations and guidelines, including City Municipal Code Section 17.80.040, "Residential Accessory Structures and Use Regulations."
- 4-2 On-site parking may be an attached or detached garage. Attached garages should be recessed a minimum of 3 feet behind the front facade (the main front wall) of the home. However, garages that are recessed 3 feet behind the front of the porch will be considered on a case-by-case basis.
- 4-3 Detached garages are recommended for new infill homes, where feasible. If alley access is available, detached garages should be placed in the rear yard. When alley access is not feasible, front access is acceptable.
- 4-4 Garage design, siding, roofing, trim, and window materials should match the materials used on the home.
- 4-5 City Municipal Code permits a carport if 50% or more of the dwellings on the block do not have enclosed parking. The carport should be designed to the same standards as an enclosed garage, with similar roofing materials and roof pitch.



This attached garage is recessed from the front facade of the home.



Front access to a detached garage at rear of home is common in the Residential Character Area.

Single-family Residential



Reduced alley aprons decrease pavement runoff.

Residential Character Area Guidelines

- 4-6 Garages should be subordinate to the primary structure and shall match its character and materials.
- 4-7 Garage doors should be unobtrusive in neighborhoods with older homes. Siding that matches the siding used on the home may be used to cover the garage door to minimize its appearance.
- 4-8 Traditional carriage-style garage doors are acceptable if appropriate for the design of the house and the existing neighborhood context.

Sustainability Guidelines

- 4-9 Single-car garages or tandem garages are encouraged to reduce the extent of paved driveway areas.
- 4-10 Reduced alley aprons are encouraged to decrease pavement runoff.

Single-family Residential

5 Parking

Design Principle

On-site parking shall be located at the side or rear of the lot, whenever feasible, to minimize parking along the facade facing the street and afford an unobstructed and attractive view of the home.

Rationale

Many homes have been designed with extensive driveway paving and parking at the front of the home. Infill development should place driveways and parking pads toward the side of the lot so that the front yard is visually attractive and can be landscaped.

General Design Standards and Guidelines

- 5-1 Parking shall conform to all relevant City of Sacramento regulations and guidelines, including the City Municipal Code Section 17.64.020 "Parking Requirement by Land Use Type," which states that one off-street parking space is required per dwelling unit.
- 5-2 Alley access is preferred in areas where it is available.
- 5-3 Concrete and asphalt are typical driveway paving materials. Alternative driveway paving surfaces, such as mortared brick or concrete pavers, and tinted concrete, are encouraged to minimize the appearance of a monotonous paved front yard. Permeable materials, such as pavers, cobblestone, or similar treatments, are also recommended paving materials for driveways. Driveway strips with turf between the strips are another desirable alternative. Alternative treatments must be approved by the relevant reviewing agencies per City development standards for paving surfaces.

Residential Character Area Guidelines

- 5-4 Some older Oak Park homes have shared driveways between two adjacent lots. This is encouraged, where feasible, to minimize the paved area at the front of the home.



Only on-street parking is available in some parts of Oak Park.



Alternative driveway materials, such as turf strips, can minimize the amount of paving in driveways.



Access to the garage and back yard can be provided via an alley.



A shared driveway that minimizes the amount of space taken up by parking and the driveway can be found in some homes in the Residential Character Area.

ARCHITECTURE

Architecture addresses the built form of the home, along with its detailing. Infill homes and additions to existing homes should respect the architectural style of established homes on the block, while also reflecting contemporary construction methods.

Oak Park has experienced decades of infill development, which lends interest and variety to the neighborhood. New homes can continue this trend by bringing fresh new styles while still emphasizing respect for the overall scale of the neighborhood.

All architectural elements should be constructed of high-quality materials to promote longevity and a pleasing appearance. Variety of design and materials is desirable if complementary to the existing neighborhood context.



Older brick home in the Residential Character Area

6 Architectural Character and Detailing

Design Principle

An infill home shall be designed in a cohesive architectural style that complements the best examples of existing residential development on the block.

Rationale

Structures that are compatible with existing homes contribute to a sense of place and add to the character of the neighborhood. Use of stylistically cohesive, character-defining features, such as porches, columns, balustrades, brackets, rafters, and decorative trim, enhances visual compatibility.

General Design Standards and Guidelines

- 6-1 The architectural design of infill construction should complement the architectural styles of existing homes on the block. If there is a mixture of styles on a block, then the design of infill construction may be more flexibly interpreted.
- 6-2 New stylistic interpretations of traditional architecture are encouraged. The plans should follow fundamental design principles without copying them.
- 6-3 Architectural features and detailing should be proportional to the scale of the home, as well as to other homes on the block of a similar architectural style.
- 6-4 Additions should be designed with architectural details that are similar to those of the existing structure, but simpler and visually distinguishable.
- 6-5 Individual elements in a structure should be consistent with that structure's overall design or style.
- 6-6 A contemporary sundeck may be added to an existing structure, provided that it does not visually detract from the main building. The scale, material, color, and details of the deck should be compatible with the existing building. Removal of significant features of the existing building, such as a porch, is strongly discouraged.
- 6-7 All elevations should be given equal design treatment and architectural consideration.



Infill home with detailing in scale with the home



Renovated Oak Park home

Single-family Residential



Gable roof with front-facing gables



Gable roof with side-facing gables and shed-roofed dormer windows



Gable roof with clipped end



Hip roof with hip dormer



Steeply pitched, front-facing gable roof

7 Roof Styles

Design Principle

The design of a roof on an infill home shall correspond to the prevailing designs of roofs on homes in the established neighborhood context. The design of the roof on additions and renovations shall correspond to the roof style and pitch of the existing structure.

Rationale

The pitch, style, and orientation of the roof in an infill home should be similar, but not necessarily identical to, the roof styles of existing homes on the block to encourage respect for the established context while allowing for variety. However, the pitch, style, and orientation of the roof on a renovation or addition should be identical to that of the existing home. Any crossing gables should match the established pitch and style of the existing roof.

General Design Standards and Guidelines

- 7-1 The roof pitch and overhang on infill structures should be similar to those of existing homes on the block.
- 7-2 Flat roofs are discouraged and should be used only if they are common in neighboring residences.
- 7-3 Infill homes should respect the primary gable orientation of the majority of existing homes on the block.
- 7-4 The roof forms and slopes of additions should be similar to those of the original structure. The roof of the addition should be subordinate to that of the primary building. Gable, hip, and shed roofs are appropriate for additions.

Single-family Residential

- 7-5 A dormer addition should be compatible with the scale of the primary structure. The number and size of dormers should not be visually overwhelming. New dormers should be placed below the ridgeline of the primary roof.

Residential Character Area Design Guidelines

- 7-6 Homes in the Residential Character Area often have an established rhythm of roof elements on a block. For example, homes may have the same roof pitch, while displaying variety in details such as dormers and gable orientation. This allows for coherence of design, as well as variety, that should be followed in infill homes.
- 7-7 Deep eaves and soffits are encouraged where they are suitable to the style of the home and the neighborhood context.

Sustainability Guidelines

- 7-8 Roof overhangs ranging from 18 to 36 inches are encouraged to promote window shading and building longevity when appropriate to the architectural design of the home.



Deep eaves and overhangs can help to shade and protect the home.

Single-family Residential

8 Entry Features

Design Principle

Infill homes and additions to the front facade of the home shall have an entry feature such as a porch or stoop that faces the street side.

Rationale

Entry features accent the front facade of a home and add visual interest. Entry features and their components, such as columns and steps, should be proportional to the overall scale of the home.

Porches and other entry features are a common architectural element in homes in the Residential Character Area. Porch elements in these older homes differ greatly, ranging from the solid, square columns of Craftsman homes to the delicate turned balusters in Queen Anne homes. Entry features on infill homes should be consistent in design and scale with the new home and the predominant style on the block.

General Design Standards and Guidelines

- 8-1 Entry features are encouraged on all new infill homes, and are a recommended renovation for existing homes, where feasible.
- 8-2 Entry porches and porticoes in two-story homes should be one story to minimize the appearance of bulk.
- 8-3 Entry features should be built to a depth of 6 feet from the front of the entry feature to the front facade of the home; however, shallower entry features will be considered on a case-by-case basis.
- 8-4 The scale and style of porch and portico elements should be consistent with the scale and style of the home, and should strive to respect the scale and style of porch and portico elements in the other homes on the block.
- 8-5 Porch and portico columns should be given some form of detailing, such as a defined plinth and capital.
- 8-6 Porch columns and railings should be constructed of high-quality materials that complement the materials used in the overall exterior of the home.



This full-front porch in the Residential Character Area shows Craftsman influences.



The porch on this infill home is similar to other porches in the neighborhood, without being identical.



This entry feature adds dynamic interest to an older home in the Residential Character Area.

9 Doors

Design Principle

Doors shall be made of high-quality materials and include decorative elements such as raised panels, sidelights, and transoms that are appropriate to the overall design of the home.

Rationale

Doors are an important architectural feature that offer security and visual appeal. For this reason, doors should be made of high-quality materials that protect the home, while also offering aesthetic appeal through decorative elements that correspond to the style of the home.

General Design Standards and Guidelines

- 9-1 Doors are character-defining features of a home and should be appropriately designed to contribute to the overall composition of the house.
- 9-2 Doors should not be flat surfaces, but should include raised panels, glass, or some other form of detailing and articulation.
- 9-3 Doors should be of high-quality materials, such as metal or solid-core wood.
- 9-4 Doors may be metal or wood-framed. High-quality metal framing can afford enhanced security and fire protection and should be considered. Whether wood or metal, door framing should be slightly recessed or extended to lend interest and definition to the entry.
- 9-5 Horizontal sliding doors are highly discouraged.

Residential Character Area Design Guidelines

- 9-6 Doors should reflect the style of the home and be constructed of materials appropriate to that style. If an infill home, the door should reflect the styles of other homes on the block.



Door with decorative metal and inset glazing

Photo Courtesy of DesignLens



Door with sidelights and inset panels

Single-family Residential



Window detailing, such as shutters, adds interest.

Photo Courtesy of DesignLens



Casement window with wooden frame and sills



Single-hung windows with wooden frame



Window detailing

Photo Courtesy of DesignLens

10 Windows

Design Principle

Windows shall be constructed of high-quality materials and designed to complement the style of the home.

Rationale

High-quality materials and construction techniques ensure the longevity of windows and enhance their aesthetic appeal.

General Design Standards and Guidelines

- 10-1 Windows should complement the style of the home.
- 10-2 Windows with multiple panes provide interest and definition to a home's facade and are encouraged.
- 10-3 Window frames, sash, trim, and sills may be wood, vinyl, or a paintable fiberglass composite. Unpainted metal is not allowed.
- 10-4 A consistent window treatment should be used on all sides of the building.
- 10-5 Reflective or tinted glass and opaque plastic skylights are discouraged.
- 10-6 Windows used in additions and renovations should be similar to those in the primary structure.

Residential Character Area Design Guidelines

- 10-7 Recommended window styles include casement, single-hung sash, and double-hung sash windows.
- 10-8 Horizontal sliding doors are highly discouraged.
- 10-9 Windows should be finished with trim elements similar in dimensions to those used on other homes on the block.
- 10-10 Window frames should be constructed of wood.

Sustainability Guidelines

- 10-11 The use of insulating glazing such as LoE² is encouraged to increase energy efficiency.
- 10-12 Prismatic glazing is encouraged to increase the energy efficiency of skylights.
- 10-13 Daylighting should be incorporated into the architectural design of the home, where feasible, to increase energy efficiency.



Daylighting increases energy efficiency.

11 Siding

Design Principle

The siding used on an infill home or addition to an existing home shall be durable, consistent with the style and character of the home, and complement the siding materials used on other homes on the block.

Rationale

Siding should not only complement the style of a new infill home, but should be consistent with siding materials commonly used on other homes in the neighborhood to avoid appearing out of context. Siding materials in additions and renovations should match the siding on the existing home to the greatest extent possible.

Common siding materials used on homes in the Residential Character Area include brick, wood lap siding, and stucco. The predominant material depends on the predominant style of home in the area.

General Design Standards and Guidelines

- 11-1 The siding used on infill homes should follow the form of siding used on the majority of existing homes on the block. Where no form of siding is predominant on the block, wood lap siding, brick, stone, and stucco are acceptable materials.
- 11-2 Wood lap siding should be applied horizontally and should be similar in scale, proportion, texture, and finish to wood lap siding used on the original building or on the block.
- 11-3 Several lap siding materials are available, with some recommended over others:

Recommended:	Discouraged:
Wood	Vinyl
Cement Fiber	T1-11
	Aluminum

- 11-4 Stucco must be smooth, troweled plaster. Spray-on, "popcorn" stucco is not allowed, and foam trim sprayed with stucco should be avoided.
- 11-5 The use of two materials, with one employed as wainscoting, can often add to the interest of the home.
- 11-6 Avoid highly reflective metals, glass, plastic, and vinyl.

Residential Character Area Design Guidelines

- 11-7 The color, texture, bonding pattern, and grout profile of brick should be similar to established uses of brick on the original building and in the neighborhood.



Wood lap siding

© 2005 JupiterImages Corporation



Smooth stucco



Brick



Brick wainscoting on smooth stucco



Laminated dimensional shingles

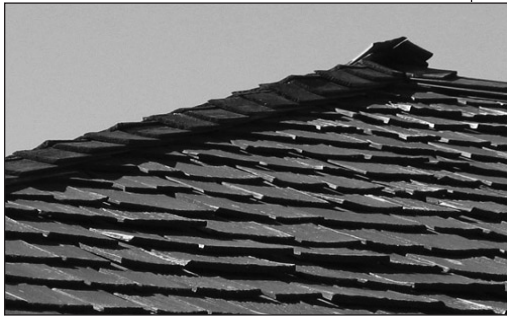

Wood shakes



Lightweight concrete shingles



Tile shingles

12 Roofing

Design Principle

Roofing on an infill home shall be durable and complement the style of the home. Roofing on an addition or renovation shall be durable, and complement the roofing on the existing home.

Rationale

Roofing materials should be durable to ensure their attractiveness and continued functionality for many years. Roofing materials should also be suitable for the context. For example, high-quality metal roofing may be appropriate in some rural or resort settings, but is uncommon in the Oak Park neighborhood and therefore inappropriate.

General Design Standards and Guidelines

- 12-1 Roofing materials must have a minimum 30-year guarantee. Roofing with a 40-year guarantee is encouraged.
- 12-2 The color and materials used for roofing should complement the color and architectural style of the home. Accent colors may be used, but they should not overwhelm the home or clash with other homes on the block.
- 12-3 The following materials are recommended:
 - laminated dimensional (asphalt) shingles;
 - wood shingles/shakes;
 - laminated dimensional fiberglass shingles;
 - lightweight concrete shingles;
 - terra cotta tile or lightweight concrete tile; or
 - slate shingles.

Single-family Residential

- 12-4 Metal roofing is typically inappropriate and highly discouraged.
- 12-5 Composition shingles should only be rolled over side barge boards when appropriate to the overall design of the structure.
- 12-6 When installing gutters, rafter tails should only be trimmed when the rafter tail design is not an architectural feature specific to the overall design of the structure.

Residential Character Area Design Guidelines

- 12-7 Ogee gutters should be used on structures built in a traditional style. Fascia gutters are more appropriate to ranch style and mid-century modern homes.

Sustainability Guidelines

- 12-8 Photovoltaic solar panels or solar shingles such as “solar slate” are encouraged to reduce the home’s use of energy from conventional sources.
- 12-9 Homeowners are encouraged to consider roofing options that include recycled content.
- 12-10 The use of “cool roof” options, including lighter colored roofing and reflective coatings, is encouraged to achieve energy efficiency.



“Cool roof” options can achieve higher energy efficiency.

Photo Courtesy of Met Tile

Single-family Residential



Simple, streamlined lighting fixtures can complement a wide variety of home styles.



High-quality lighting fixtures can enhance the appearance of the home.

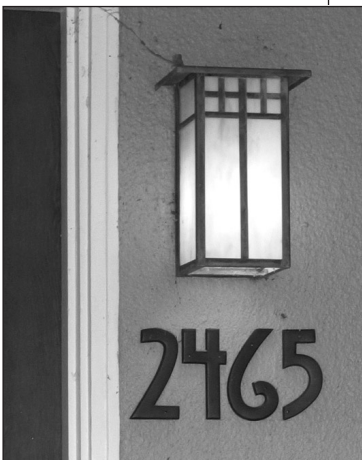

Addresses should be illuminated and easily visible from the street.

13 Lighting and Addresses

Design Principle

Light fixtures shall be consistent with the architectural style of the home and shall provide adequate illumination of the front entry and addresses so that both are clearly visible from the street.

Rationale

To assist emergency vehicles and contribute to the safety of the home, address lettering should be affixed near the door and should be large enough to be seen from the street. Lighting fixtures should be adequate to illuminate the addresses and the front entryway.

General Design Standards and Guidelines

- 13-1 Lighting contributes to the security of the home and is required for the front entryway, walkways, and garage area. Recessed entryways should be clearly lit.
- 13-2 Lighting fixtures should be designed for exterior use and should be weather resistant.
- 13-3 The address should be illuminated and clearly visible at night.
- 13-4 The address should be visible from the street.
- 13-5 Address numbers should be 4-8 inches high.
- 13-6 The preferred location to display the address is affixed to the front of the home, adjacent to the front door. If structural considerations preclude affixing the address adjacent to the front door, then the address may be attached on the front of the home or garage as long as it is still clearly visible from the street and illuminated at night.
- 13-7 Lighting fixtures should be directed away from adjacent areas to minimize light pollution.

Sustainability Guidelines

- 13-8 Compact fluorescent bulbs and photocell sensors are encouraged to achieve energy efficiency.

Single-family Residential

SITE ELEMENTS

Site elements include those features that are auxiliary to the home, such as landscaping, fencing, and paving. Site elements are typically used to enhance the appearance and functionality of the home.

High-quality site elements can increase the beauty and value of the home, and when carefully selected, can also contribute to the visual continuity of the street.



Mature landscaping is essential to the established character of the Oak Park neighborhood.

Single-family Residential

14 Landscaping

Design Principle

Landscaping shall be used around the home to positively contribute to its appearance and give a sense of visual continuity along the street. The front yard shall be planted with landscaping materials that may include a mixture of turf, groundcover, and decorative shrubs.

Rationale

A variety of landscaping plants and materials can contribute to a positive sense of place in a neighborhood. Trees provide shade, reduce energy consumption in the summer, help to filter air pollution, and provide visual interest along the street. Oak Park has many mature trees that contribute to the positive character of the neighborhood.

General Design Standards and Guidelines

- 14-1 Landscaping shall conform to all relevant City regulations and guidelines, including the City Municipal Code Section 17.68.010, "Landscaping requirements," which states that a maximum of 40% of the front yard setback may be paved for parking and driveways, with an additional 10% for walkways or uncovered patio use. The remaining portion of the yard must be landscaped.
- 14-2 Alternatives to turf, such as groundcover that can tolerate foot traffic, are encouraged.
- 14-3 Bare soil should be planted or mulched with bark, stone, or other suitable materials to avoid unnecessary runoff.
- 14-4 A minimum of two trees should be planted in the front yard. A minimum of three trees should be planted at homes on corner lots where the size of the yard permits full canopy growth.
- 14-5 Street trees should be retained. Consult the City Parks and Trees Service at 916-808-5200 for questions regarding the care of street trees. Private tree services are available for consultation before trimming or removal of mature trees on private lots.



Landscaped areas should be mulched with bark or stone.



Groundcover can provide a low-water alternative to turf.



Thymus species provide another groundcover alternative to turf.

Single-family Residential

- 14-6 Refer to the following lists for more information about recommended species:

Sacramento Tree Foundation

www.sactree.com/treeInfo/treesWeOffer.html

Sacramento Municipal Utility District (SMUD)

www.smud.org/residential/saving/trees/index.html

City of Sacramento Department of Parks and Recreation

www.cityofsacramento.org/parksandrecreation/urbanforest/index.html

- 14-7 Street trees and plant species should be suitable for the Sacramento climate. Low-water landscaping materials are encouraged to conserve water.
- 14-8 Trees species should be selected so that each tree's canopy at full growth can be accommodated by the site. A variety of tree species representing a range of sizes will contribute to the visual interest of the yard and is recommended.

Sustainability Guidelines

- 14-9 Homeowners are particularly encouraged to plant deciduous shade trees and shrubs that shade the west and south sides of the home to minimize solar heat gain and increase energy efficiency.
- 14-10 Shade trees should be planted to shade pavement areas to reduce heat transmission and energy consumption.
- 14-11 New planting strips located between the sidewalk and street should be a minimum of 6 feet wide to promote the health of shade trees.



Trees can offer shade and reduce cooling costs during the hot summer months.



Native and low water use ornamental plants can significantly reduce water consumption.



Well cared for, mature trees can add significantly to the beauty of a home.

Single-family Residential



A conventional spray system is most effective for turf and groundcover.



A drip irrigation system provides deeper watering for shrubs and trees.

15 Irrigation

Design Principle

Irrigation is essential to maintain the health and beauty of a home's landscaping and shall be provided for all infill homes.

Rationale

The seasonal extremes of the Sacramento climate make regular irrigation of planted areas mandatory. Automatic irrigation ensures regular and consistent watering, and promotes healthy landscaping.

General Design Standards and Guidelines

- 15-1 An automatic irrigation system should be installed in the front yard to provide consistent coverage of all planted areas. A home on a corner lot should have an automatic irrigation system that covers the yard fronting both streets. Automatic controllers with rain shut-off valves provide greater water conservation.
- 15-2 If there is a front planting strip, the homeowner is responsible for irrigation and the maintenance of it.
- 15-3 Turf and groundcover are more effectively irrigated with a conventional spray system. Head-to-head spray coverage is recommended. Avoid overspray onto sidewalks and adjacent properties.
- 15-4 A drip irrigation system is recommended for shrubs and trees to provide deeper, more even watering. Drip irrigation also permits greater water conservation than a conventional spray system.
- 15-5 Irrigation controls must be screened from view by landscaping or other attractive site materials.

16 Fencing

Design Principle

Fencing must be of high quality materials that are consistent with the style of the home to enhance the overall character of the home and contribute to the positive appearance of the neighborhood.

Rationale

Fencing should be selected for its decorative qualities and should complement the character of the home as well as the overall character of the neighborhood.

General Design Standards and Guidelines

- 16-1 Fencing shall be located and constructed in conformance with the Sacramento Municipal Code Section 15.156, "Fences," and Section 17.76, "Wall, Fence and Gate Regulations."
- 16-2 Fencing must allow unobstructed visibility of the front entrance, and in the case of homes on corner lots, the front and any side entrances.
- 16-3 Front yard fencing should have a minimum of 50% transparency.
- 16-4 The style, materials, and color of the fencing should complement the style, materials, and color of the home.
- 16-5 High-quality materials, including wood, metal, stucco, and some forms of vinyl fencing, are acceptable fencing materials. Stucco must be smooth plaster.
- 16-6 Chain link fencing is highly discouraged for use as a front yard feature. Solid stucco walls are also discouraged, but stucco may be used in conjunction with other materials.

Residential Character Area Design Guidelines

- 16-7 Front yard fencing for infill homes is discouraged on blocks in the Residential Character Area where the majority of the homes do not have front yard fencing. (For an example, see the Site Elements introduction page.)

Sustainability Guidelines

- 16-8 The use of chlorine-based vinyl fencing is discouraged.



Brick and metal mixed materials



Wooden side yard fence

Single-family Residential



Brick



Flagstone mortared on concrete

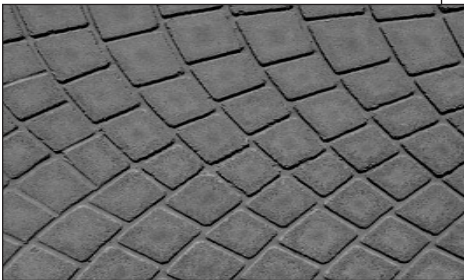

Patterned Concrete

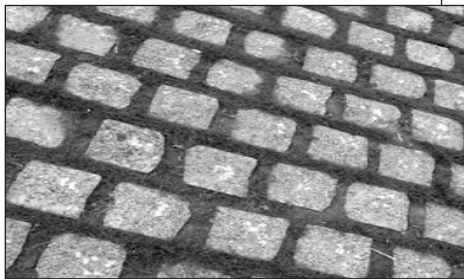

Stone with turf

17 Paving/Hardscaping Surfaces

Design Principle

The paving materials selected shall contribute to the overall appearance of the home. Impervious paving surfaces shall be minimized, and limited to the driveway, walkways, and patios.

Rationale

Large areas of impervious paving surfaces made up of materials such as concrete and asphalt should be minimized at the front of the home. Instead, alternatives, such as brick, stone, concrete pavers, and patterned concrete should be used as appropriate. Some of these alternative forms of paving can offer the added benefit of minimizing stormwater run-off and the need for supplementary irrigation, as water is able to percolate down through the spaces between paving units.

General Design Standards and Guidelines

- 17-1 Paved areas shall not exceed those defined by City Municipal Code Section 17.68.010, "Landscaping requirements," which states that a maximum of 40% of the front yard setback may be paved for parking and driveways, with an additional 10% for walkways or uncovered patio use.
- 17-2 Alternative paving surfaces, such as concrete pavers, brick, or stone are encouraged for driveway surfaces to reduce the appearance of large, paved areas.
- 17-3 Alternative paving surfaces that help to keep stormwater runoff on-site are encouraged.

Residential Character Area Design Guidelines

- 17-4 Alternative driveway and paving treatments are common in older homes in the Residential Character Area and can provide guidance for new infill homes.

18 Utilities and Storage Facilities

Design Principle

The visibility of utilities and storage facilities shall be minimized by placing them at the side or rear of the home and screening them from view from the street.

Rationale

Utilities and service features are less attractive but necessary parts of the home. These features should be placed at the side or rear of the home, and screened by fences and landscaping. Alley access can facilitate placement of and access to these features at the rear of the home.

General Design Standards and Guidelines

- 18-1 Trash receptacles should be placed in the side or rear yard and adequately screened by landscaping or a side yard fence.
- 18-2 Storage sheds should be located in the rear yard. Placement in the side yard is acceptable if the shed is adequately screened by landscaping or a side yard fence.
- 18-3 Accessory structures should be similar in character and materials to the main building, but subordinate in massing, scale, and height.
- 18-4 Antennae should be mounted at the rear of the home. Satellite dishes should be mounted on the home to minimize their visibility.
- 18-5 Heating and cooling units should not be roof-mounted or placed at the front of the home. Heating and cooling units should be placed in the attic or at the side or rear of the home and screened by a side yard fence or landscaping. Solar panels do not need to be screened.

Sustainability Guidelines

- 18-6 Where feasible, heating, ventilation, and air conditioning units should be placed on the north side of the primary structure or garage (if not the street side) to shade the units and minimize energy consumption.



This utility box should be screened by landscaping.



A conspicuous antenna is highly discouraged.

19 Access Ramps

Design Principle

Ramps that provide access to the front or side of the home shall be safe, designed to match the style of the home, and constructed of durable materials that complement those used on the home.

Rationale

Ramps that provide universal access to single-family homes should be designed so that they look like they are a part of the home to the greatest extent possible. The ramp should be designed to minimize its size and bulk without compromising safety and ease of access. Materials used should complement those used on the home, i.e., a concrete ramp with brick facing could be used on a brick home, while a wooden ramp might be more suitable for a home with wood lap siding.

Design Guidelines

- 19-1 Any ramp providing access to a single-family residence shall be designed to meet standards found in the Americans with Disabilities Act, available for review at:
www.ada.gov/stdspdf.htm
- Under ADA standards, a ramp shall be designed with a slope ranging between 1:12 and 1:20 (5 to 8% slope), and shall include 60-inch landings at the top and bottom of any run. A handrail shall be included on all ramps higher than 6 inches.
- 19-2 The ramp should be designed so that it does not detract from existing architectural elements at the front of the home. The specific location and angle of the ramp may vary, depending on the design of the home and its location on the lot.
- 19-3 Ramps should be constructed of sturdy, long-lasting materials, such as wood, brick, or concrete. Ramp material(s) should complement those used on the home. Where appropriate, facing materials used on the home may be affixed to the side of the ramp.
- 19-4 Modular aluminum ramps are discouraged from use at the front of the home.

Multi-family Residential

The Multi-family Design Standards and Guidelines outline good design practices for infill multi-family development (defined as residential structures with three or more units). Emphasis is given to design that will allow multi-family units near established single-family homes to complement those homes without appearing too massive or out of scale.

Multi-family or mixed-use development on or in the immediate vicinity of Broadway or Stockton Boulevard should be designed to complement the commercial development in those commercial character areas. (See the Commercial section of these Design Guidelines.) Multi-family development on Broadway, for instance, should emphasize traditional design, with brick as a preferred exterior material, whereas multi-family structures on Stockton Boulevard may be more contemporary in design, with a stucco or brick as acceptable siding materials.

The architecture of multi-family structures in the Residential Character Area should reflect traditional design and materials commonly used in styles prior to World War II. Contemporary or minimalist designs should be avoided.



This multi-family development has been designed with architectural features similar to those in single-family homes.

Multi-family Residential

SITE DESIGN

This section discusses the location of multi-family structures on the lot, their orientation toward the street and adjacent buildings, and the location of parking lots and parking structures,

Good site design of multi-family structures should ensure that residents can easily access them from the street, with entryways clearly located on the street side. Parking areas, utilities, and service facilities should be located toward the rear of the site. Common spaces should be toward the interior of the site so that all residents can easily access these facilities, and to provide additional safety for small children.

Setbacks for multi-family structures should be similar to those for established structures in the area. If the established context consists of single-family homes, multi-family structures should have similar setbacks, and the design of the multi-family structures should minimize the mass of the buildings. Multi-family structures located in or near commercial districts may have smaller setbacks similar to those of commercial buildings.



A multi-family structure with defined entries, gates, and paths

Multi-family Residential

20 Relationship to the Street

Design Principle

Multi-family structures shall present a facade that encourages interaction with the street by including entry features, windows, and landscaping along the street side of the building.

Rationale

Multi-family structures that are adjacent to a public street should encourage residents to actively engage with that street through a variety of design elements. In addition to improving the visual quality of the streetscape, design elements should allow residents to see and be seen from the street, enhancing neighborhood interaction and improving safety.

Design Standards and Guidelines

- 20-1 Multi-family structures that present a blank wall to the street are not allowed.
- 20-2 Multi-family structures that are constructed as infill near an existing single-family residential neighborhood should provide a streetside facade that is complementary to these single-family homes in style and massing.
- 20-3 Multi-family structures should have entry features that front onto the street, including a door and porch or stoop that relate directly to the street frontage.
- 20-4 Recessed entry features are strongly discouraged. Residents should be able to see and be seen as they enter and exit their residences.
- 20-5 Streetside windows should be installed that provide views of the street from active living spaces.
- 20-6 Small, landscaped private entry yards afford an attractive appearance on the street side and allow residents to control and take pride in these areas.
- 20-7 Pedestrians should have clear, unobstructed access to the street and to nearby transit stops.
- 20-8 Paths and access points should be clearly visible during the day and well lit after dark.

Sustainability Guidelines

- 20-9 Street trees should be planted within planting strips and yards to provide shade and increase energy efficiency.



Blank walls facing the street should be avoided.



Private front yards that are visible to the street can help residents to see and engage with the public realm.

Multi-family Residential

21 Setbacks

Design Principle

Setbacks of multi-family residential structures shall be consistent with the appropriate commercial or residential context.

Rationale

When multi-family residential structures are placed on busy commercial streets, smaller setbacks that locate the building closer to the street are the norm. Multi-family structures constructed near single-family residential neighborhoods should reflect the larger setbacks typically found in those areas.

Design Standards and Guidelines

- 21-1 Large multi-family developments should be designed with varied setbacks that contribute to an interesting streetscape and avoid a monotonous streetwall. Continuous lines of buildings with the same setback should be avoided.
- 21-2 Individual buildings can also be designed with an articulated front, with porches closer to the street than recessed garages.
- 21-3 In residential neighborhoods, multi-family housing should adopt the predominant setback, but should also vary the building facade to relieve the appearance of mass.



These multi-family homes have been designed with setbacks and architectural features similar to those found in single-family homes.

22 Interior Common Spaces

Design Principle

Multi-family structures shall provide interior common spaces that are easily accessible to residents. Individual units adjacent to common spaces shall have facades with entry features and windows that open onto those common spaces.

Rationale

Interior common spaces should ideally foster a sense of community. This can be facilitated by building facades that allow residents to see and easily use common spaces. Common spaces should offer amenities that invite use, such as seating, shade, and tot lots.

Design Standards and Guidelines

- 22-1 Ground floor units should have doorways that open onto interior common spaces.
- 22-2 All units that overlook interior common spaces should have windows from active living spaces that allow residents to easily see common areas.
- 22-3 Common amenities, such as tot lots, seating areas, and swimming pools, should be provided that cater to all age ranges, from small children to the elderly, as appropriate.
- 22-4 Common facilities such as recreation rooms, and laundry and mail areas should be located adjacent to common open space to increase activity in these areas.
- 22-5 Common open space should be designed as a visible, accessible transition between the street and individual units.



Interior common spaces can offer seating and areas for informal activities.



This multi-family development offers inviting interior common space with a landscaped picnic area.

Multi-family Residential

23 Scale and Mass

Design Principle

The scale and mass of multi-family residential structures shall be consistent with the scale and mass of existing structures in the vicinity.

Rationale

Multi-family development should use design and construction methods that minimize the appearance of mass with multiple rooflines, articulated facades, and architectural detailing that break up the facade.

Design Standards and Guidelines

- 23-1 Multi-family structures that are constructed as infill near an existing single-family residential neighborhood should provide a streetside facade that is complementary to these single-family homes in style and massing.
- 23-2 Two-story structures should have articulated facades to minimize the appearance of mass.
- 23-3 Two-story structures should have multiple rooflines with corresponding gables that are consistent in style and materials with the overall structure.
- 23-4 Architectural elements, such as dormers and other types of decorative windows, complementary trim, porch details, decorative shutters, and wainscoting, can reduce the appearance of bulk and mass by providing visual interest.

Sustainability Guidelines

- 23-5 Whenever possible, buildings should be oriented on the site to maximize solar access on southern exposures so that features such as photovoltaic solar panels and daylighting can be incorporated into the architectural design.
- 23-6 Solar access for daylighting and solar panels should be considered in massing design. Glazing should be located predominantly on the north and south sides of the structure. Glazing on the west side of the structure should be minimized, unless the west side of the structure is the street side.



Multiple roof lines can reduce the appearance of mass in large multi-family structures.



The facade of this multi-family structure has been designed with architectural detailing to add interest and reduce mass.

Multi-family Residential

24 Parking Lots

Design Principle

Parking shall be located at the rear or interior of the complex, where feasible. Parking lots that face the street or are on the side of multi-family housing shall be minimized.

Rationale

Multi-family residential structures should encourage residents to have an active relationship with the street(s) adjacent to the development. To this end, parking lots should be located at the rear or in the interior of the development so as not to interfere with access to the street or interior common spaces.

Design Standards and Guidelines

- 24-1 Parking lots shall conform to City Municipal Code Section 17.64.030, "development standards for parking facilities," which specifies stall size and design.
- 24-2 Smaller, scattered lots will provide better access to residents and be less visually obtrusive than a single large lot.
- 24-3 Covered parking should be located so that it does not interfere with front entries or access to interior common spaces.
- 24-4 Parking areas should be screened from adjacent structures with landscaping strips. However, screening should not exceed 4 feet in height, and should be permeable so that areas can be viewed by passing pedestrians and vehicles.
- 24-5 Underground parking in private or shared garages accessible from the street is acceptable if it does not interfere with pedestrian access to the street.
- 24-6 Podium-level parking is desirable for multi-family structures building in or near the Commercial Character Areas on Broadway and Stockton Boulevard. Parking structures on commercial streets must include a ground-floor use suitable to the context (such as commercial or office) adjacent to the street.



These units face the street, while parking is located at the rear of the building.



Parking is in small, dispersed lots in the interior of this multi-family development. The materials on the carport also match those on the main buildings.

Multi-family Residential

ARCHITECTURAL ELEMENTS

This section addresses the specific structural elements that can contribute to the positive appearance of multi-family housing. All architectural elements should be constructed of high-quality materials to promote longevity and a visually pleasing appearance. Variety of design and materials is desirable if complementary to the existing neighborhood. If located in an established residential neighborhood, multi-family housing shall be designed with architectural features that complement the character of adjacent single-family homes.



These townhomes have facade details and colors that distinguish them as individual units.

Photo courtesy of DesignLens

25 Garages

Design Principle

The visibility of multi-family garages from the street shall be minimized. Instead, garages shall be located beneath, at the side, or at the rear of multi-family structures. Garage and carport materials and architectural styles shall complement the materials and styles of the primary buildings.

Rationale

To minimize the visual prominence of garages, they should be placed underneath or at the side or rear of multi-family structures. Garages should be grouped in small clusters rather than unbroken lines.

Design Standards and Guidelines

- 25-1 Garages should be varied in their location to minimize the impact of a row of garage doors.
- 25-2 Rows of garages or carports around the perimeter of a development should be avoided.

Sustainability Guidelines

- 25-3 The use of photovoltaic solar panels on carports is encouraged.
- 25-4 Garages and parking structures should incorporate tandem parking whenever feasible to reduce the extent of paved driveway areas.
- 25-5 Reduced alley aprons are encouraged to decrease pavement runoff.



The garages are located at the rear of this multi-family structure.

Multi-family Residential

26 Entry Features

Design Principle

The principal entry to each unit shall be clearly visible from the street and include a porch, stoop, or other entry feature.

Rationale

To give definition to the facade of multi-family structures and provide visual interest, entryways should be defined by entry features such as a porch, stoop, portico, or overhang.

Design Standards and Guidelines

- 26-1 Entryways to individual units should include some form of entry feature, such as a porch or portico, that adds visual interest to the overall structure.
- 26-2 To promote visibility and security, front doorways should not be recessed to the extent that they are not clearly visible.
- 26-3 The style of porch and portico columns should be consistent with the scale and style of the building.
- 26-4 Porch columns and railings should be constructed of high-quality materials that complement the materials used in the overall structure.
- 26-5 Where individual units face onto a public street, each unit should be designed with a walkway from the sidewalk to the front entry feature.



Landscaping and a small entry feature leading to each unit mark this multi-family structure.



These attached units have individual porches.

27 Lighting

Design Principle

All common areas and accessways shall be adequately lit during low-light periods. Light fixture design shall complement building architectural style.

Rationale

Lighting fixtures should be selected with consideration for the type of use in each area of the complex. Parking lots should be adequately lit so that residents and visitors can easily negotiate parking areas. The lighting of paths and walkways should be adequate for pedestrians to walk safely without light spillover into nearby units. The design and style of light fixtures should complement the style of the buildings.

Design Standards and Guidelines

- 27-1 Lighting should be provided in all common areas, including parking, vehicular and pedestrian entries, walkways, and at common facilities such as mailboxes and swimming pools.
- 27-2 Lighting fixtures should be designed for exterior use and should be weather resistant.
- 27-3 Materials, size, color, and design of light fixtures should be consistent with the style of the structures.
- 27-4 Ornamental pedestrian lighting in common areas should not exceed 12 feet in height. Lighting for parking areas should not exceed 14 feet in height. Pedestrian lighting, such as lighted bollards, should not exceed 4 feet in height.
- 27-5 Lighting of parking lots, landscaping, and pedestrian walkways should not result in light spillover to interior residential units or adjacent homes, and should not cast glare on the public way and adjacent properties.
- 27-6 Light fixtures should be selected to attract attention to the building details instead of the fixtures themselves.
- 27-7 The lights should provide even illumination levels. Flashing or pulsating light fixtures should be avoided.

Residential Character Area Design Guidelines

- 27-8 Lighting in the Residential Character Area should complement the architectural style of the building.

Sustainability Guidelines

- 27-9 Compact fluorescent bulbs and photocell sensors are encouraged to achieve energy efficiency.



Decorative pedestrian lighting that complements nearby residential structures

Photo courtesy of DesignLens



Pedestrian-scaled pathway bollard lighting

Multi-family Residential



Pedestrian-scaled signage assists wayfinding within multi-family developments.

28 Signage and Addresses

Design Principle

Entry signage shall be provided at all primary access points to the complex and within the complex, as needed, to ensure wayfinding. Entry signage identifying the development and its address shall be easily visible from the street to assist visitors and emergency vehicles.

Rationale

Signage promotes wayfinding, and should be easy to read from the street and well-lit at night. Signage also contributes to the character of the complex, and should complement the style and character of the buildings.

Design Standards and Guidelines

- 28-1 Interior vehicle and pedestrian circulation routes should be clearly marked by signage.
- 28-2 Individual units should have addresses with letters that are 4-8 inches high.
- 28-3 All signage should be illuminated and clearly visible after dark.



Signage with lighting (in landscaping)



Signage with landscaping and lighting

Multi-family Residential

SITE ELEMENTS

Site elements include those features that are auxiliary to the buildings, including landscaping and fencing, and common facilities such as mailboxes and trash receptacles.



Lighting, landscaping, fencing, and other site elements have been carefully selected to enhance this new multi-family development.

Multi-family Residential

29 Landscaping

Design Principle

Landscaping shall be provided within all streetside setbacks, common areas, and parking lots to provide shade and create visually appealing exterior spaces.

Rationale

A variety of landscaping plants and materials can contribute to the visual interest of a neighborhood. Landscaping elements should be selected not only to complement the style of the multi-family structures, but also that of other buildings on the block.

Design Standards and Guidelines

- 29-1 Landscaping shall conform to all relevant City regulations and guidelines, including the City Municipal Code Section 13.64.010, "Landscaping requirements," which requires that the front and street side setbacks must be planted with landscaping materials that primarily consist of turf or low-growing groundcover.
- 29-2 Trees shall be planted in the setbacks and common areas at intervals appropriate to the full spread of the mature trees.
- 29-3 Bare soil should be planted or mulched with bark, stone, or other suitable materials to avoid unnecessary runoff.
- 29-4 Street trees should be retained. Consult the City of Sacramento Parks and Trees Service (916-264-5200) for questions regarding the care of street trees. Private tree services are available to consult before trimming or removing mature trees.



Landscaping and fencing define the common area, but interior spaces can be seen from the street.



Interior pedestrian path

Multi-family Residential

- 29-5 Plant species should be suitable for the Sacramento climate. Low-water landscaping materials are encouraged.
- 29-6 Refer to the following websites for more information about recommended species:

Sacramento Tree Foundation

www.sactree.com/treelInfo/treesWeOffer.html

Sacramento Municipal Utility District (SMUD)

www.smud.org/residential/saving/trees/index.html

City of Sacramento Department of Parks and Recreation

www.cityofsacramento.org/parksandrecreation/urbanforest/index.html

Sustainability Guidelines

- 29-7 All planting areas, including those designed to accommodate the 2-foot overhang on parking spaces, should be landscaped with groundcover or other planting materials to reduce stormwater runoff.
- 29-8 New planting strips located between the sidewalk and street should be a minimum of 6 feet wide to promote the health of shade trees.
- 29-9 Paved and hardscaped surfaces should be shaded by trees, shade structures, or photovoltaic solar panels, when possible, to reduce heat transmission and reduce energy consumption.
- 29-10 Deciduous shade trees and shrubs should be planted on the west and south sides of buildings to minimize solar heat gain and increase energy efficiency.



Landscaping can help to shade paved areas, reducing heat transmission and lowering energy costs.

Multi-family Residential



Irrigation system



A drip irrigation system provides deeper watering for shrubs and trees.

30 Irrigation

Design Principle

An automatic irrigation system shall be provided to maintain the health and positive appearance of all landscaped areas.

Rationale

The seasonal extremes of the Sacramento climate make regular irrigation of planted areas mandatory. Automatic irrigation ensures regular and consistent watering, and is desirable for the health of landscaping.

Design Standards and Guidelines

- 30-1 An irrigation system must be installed to provide consistent coverage of all landscaped areas.
- 30-2 Turf and groundcover are more effectively irrigated with a conventional spray system. Head-to-head spray coverage is recommended. Avoid overspray onto sidewalks and adjacent properties.
- 30-3 A drip irrigation system is recommended for shrubs and trees to provide deeper, more even watering. Drip irrigation also permits greater water conservation than a conventional spray system.
- 30-4 Automatic controllers with rain shut-off valves will allow for greater water conservation.
- 30-5 Irrigation controls must be screened from view by landscaping or other attractive site materials.

31 Fencing

Design Principle

Fencing shall complement the design of the buildings and define the boundary of the complex without obstructing physical or visual access.

Rationale

The design of fencing should be used to improve the appearance of the complex and enhance its character. Fencing should not obstruct access or visually screen the area, particularly on the street side of the complex.

Design Standards and Guidelines

- 31-1 Fencing shall conform to all relevant City regulations and guidelines, including the City Municipal Code Section 17.76, "Wall, Fence and Gate Regulations," which states that front fencing may not exceed 4 feet in height, while side and rear fencing may not exceed 6 feet in height.
- 31-2 Fencing should be perceived as an enhancement, not a barrier, and should not obstruct pedestrian access.
- 31-3 Fencing adjacent to any street should have a minimum of 50% transparency.
- 31-4 High-quality materials, including wood, metal, stucco, and some forms of vinyl fencing, are acceptable fencing materials. Stucco must be smooth plaster.
- 31-5 Combining materials, such as metal with brick or stucco pillars, is an attractive way to give interest to fencing and is recommended.

Sustainability Guidelines

- 31-6 The use of chlorine-based vinyl fencing is discouraged.



Fencing should be a visual enhancement of the buildings.



This fencing defines the boundaries of the complex but allows easy visibility of interior common spaces from outside the complex.

Multi-family Residential



Concrete paving can be enhanced with detailing and the use of integral color.



The interlocking pavers in this shaded parking lot help to keep stormwater runoff on-site.



Pervious paving reduces stormwater runoff.

32 Paving/Hardscaping Surfaces

Design Principle

Walkways and common areas shall incorporate decorative paving treatments and pervious paving treatments. Parking lots shall incorporate pervious paving treatments, where feasible.

Rationale

All paved areas, such as parking lots, common areas, and pedestrian walkways, can be enhanced with the use of a variety of decorative paving treatments, such as stamped concrete or concrete with integral color.

Design Standards and Guidelines

- 32-1 Impervious surfaces should be limited to driveways, parking lots, walkways, and common areas.
- 32-2 Alternative paving surfaces are encouraged for walkway surfaces in common areas, where brick, modular pavers, and various forms of stamped or integrally colored concrete are appropriate. Pedestrian walkways must balance enhanced appearance with universal access; therefore, materials such as flagstones are not appropriate for common walkways unless installed in a manner that ensures accessibility.
- 32-3 Use of permeable materials, such as permeable asphalt, grasscrete, and modular pavers, are encouraged to reduce stormwater runoff in parking lots. Where possible, drainage should be directed into planting areas to increase percolation of water runoff. Alternative paving treatments must be approved by the Building Division of the City Development Services Department.

Sustainability Guidelines

- 32-4 The use of pervious paving and bio-swales is encouraged to reduce stormwater runoff.
- 32-5 Light colored paving materials are preferred as primary paving materials to reduce heat transmission. Darker colors may be used in small amounts to add visual interest.

33 Services and Utilities

Design Principle

Accessory structures, such as mailboxes and laundry rooms, shall be easily accessible to residents. Service elements, such as trash enclosures and mechanical equipment, shall be screened from view.

Rationale

Common facilities, such as mail areas, laundry rooms, swimming pools, and playgrounds, should be easy for residents to find and use. Trash receptacles and utility boxes should be equally accessible but screened from public view to protect the visual quality of the development.

Design Standards and Guidelines

Trash and Recycling Enclosures

- 33-1 Trash and recycling receptacles should be screened from view. Landscaping around trash enclosures will help to soften and screen what may otherwise be an unattractive structure.
- 33-2 Curbs and other impediments should be avoided so that receptacles are easily accessible for trash removal.
- 33-3 Trash/recycling enclosures must be made of a durable material, such as brick, concrete, or stucco, and should complement the design of the primary structures.
- 33-4 Trash/recycling enclosures should be located so that noise and odors are not detected by nearby residents.

Storage Areas

- 33-5 Storage for personal items should be provided in structures that match the design and materials of the primary buildings.
- 33-6 Storage areas should be located so that residents can easily access them from parking areas.

Utilities/Mechanical/Heating/Ventilation, and Air Conditioning

- 33-7 The visibility of roof-mounted satellite dishes should be minimized.
- 33-8 Mechanical equipment should be included in the design of the building where possible. If this is not feasible, it should be screened with a solid enclosure and landscaping.
- 33-9 Exterior utility equipment should be placed in low-traffic areas and screened by landscaping.
- 33-10 Where feasible, heating, ventilation, and air conditioning units should be placed on the north side of buildings (if not the street side) to shade the units and minimize energy consumption.

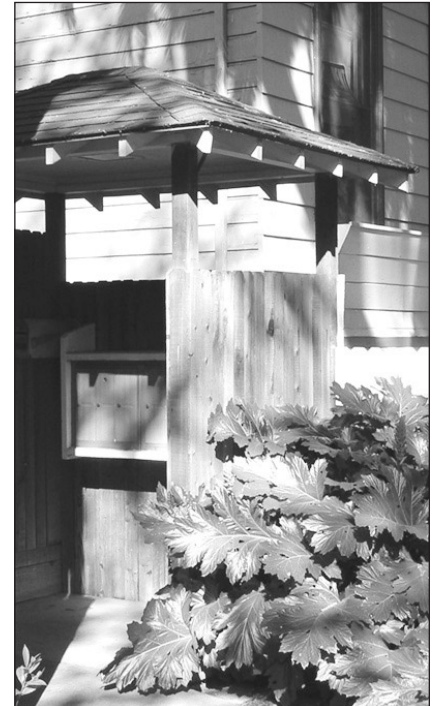

Attractive and accessible mailbox facility



Appropriate screening of HVAC unit behind fence

This Page Intentionally Left Blank

Manufactured Homes

Manufactured homes are defined as structures that are:

transportable in one or more sections, which, in the traveling mode, is 8 body feet or more in width, or 40 body feet or more in length, or, when erected on site, is 320 or more square feet (U.S. Department of Housing and Urban Development 1974).

Unlike single-family homes that are built on site, and are regulated by construction standards established by various national engineering and manufacturing boards, manufactured homes are regulated by the U.S. Department of Housing and Urban Development (HUD). HUD has established two key regulatory codes:

- National Manufactured Home Construction and Safety Standards Act of 1974 (1974 Act); and the
- Manufactured Housing Improvement Act of 2000 (2000 Act).

Both laws set national standards for construction, safety, and energy conservation during the factory production process. The 2000 Act also provides for a private sector consensus committee to make recommendations every two years on new innovations in manufactured home design.

In addition to these national laws, the State of California also regulates manufactured housing through its Mobile Homes—Manufactured Housing Act of 1980, which is primarily concerned with the proper installation of manufactured homes in mobile home parks.

Local jurisdictions may supplement the manufacturing and installation standards set by HUD and the State of California with standards that regulate the appearance and exterior amenities of manufactured homes.



Contemporary manufactured homes must include attractive architectural detailing.

Photo courtesy of California Institute of Manufactured Homes

Manufactured Homes



Contemporary manufactured homes must include a front porch entry.

Photo courtesy of Federal Trade Commission

Although manufactured homes are still fairly uncommon as infill development, they are appealing to some because they are less expensive than site-built homes. Like other forms of infill construction, however, manufactured homes must fit within the overall neighborhood context.

Manufactured homes are no longer simply long, narrow metal boxes. Instead, they can be constructed with gabled, tilt-up roofs, porches, built-in garages, and the types of siding and roofing that would be found on a typical site-built home. These design guidelines provide recommendations for the type of exterior improvements that should be made to manufactured homes to ensure that they complement existing site-built homes.

34 Setbacks, Garages, and Parking

Design Principle

The manufactured home shall reflect the architectural style and setbacks, as well as the orientation of structures and their entries of established single-family homes on the block.

Rationale

Manufactured homes are traditionally linear in design and construction, with a front entry on the long side of the home. This poses a challenge when placing them on the long, narrow lots often found in some Oak Park neighborhoods, as the “front” entry of older manufactured homes could open onto the side yard.

Newer manufactured homes are more flexible in design and construction, and can be selected to better fit into the context of single-family neighborhoods. Developers and homeowners contemplating the purchase of a manufactured home should select models and options that reflect the basic design of the single-family homes on the block where the manufactured home will be installed.

Design Guidelines

Lot Orientation and Setbacks

34-1 Setbacks and site planning should follow the same standards as site-built housing, as described in the “Single-Family Residential” section of the Design Guidelines, with the main entry on the street side.

Garages and Carports

34-2 Garages and carports provided for manufactured homes should follow the same design standards and guidelines as for site-built housing. Where possible, the garage should be integrated into the design of the manufactured home as an enclosed garage.

Parking

34-3 Parking provided for manufactured homes should follow the same design standards and guidelines as for site-built residential housing.

Manufactured Homes

35 Creating an Attractive Streetside Facade

Design Principle

The manufactured home shall be selected to create an inviting front facade that faces the street.

Rationale

Manufactured homes should be designed to provide an inviting facade on the street side that includes a door, windows, and a porch. Construction of tilt-up roofing in manufactured homes allows control over the roof pitch, which can be tailored to the neighborhood.

Design Guidelines

- 35-1 All manufactured homes should have a door that faces the street side. The entry feature should be embellished with a porch or stoop in a style similar to other homes with porches on the block.
- 35-2 The street side should have at least one window from a major interior living area (not a bathroom window).

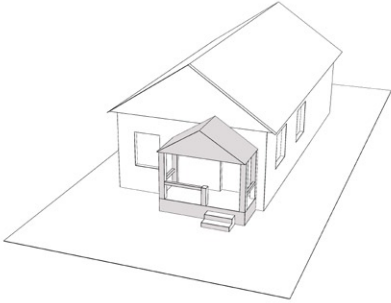

Manufactured homes must be constructed with a front porch or stoop.

36 Applying Site-Built Home Standards to Roof Design

Design Principle

The pitch and style of the roof shall not be flat, but shall be consistent with the roof pitches and styles of the established neighborhood context.

Rationale

The flat roof of older manufactured homes can be avoided. Newer models offer gable roofs with a roof pitch similar to those found in site-built homes.

Design Guidelines

- 36-1 The roof pitch should be consistent with the neighborhood context, and should have a minimum rise of 5 inches for 12 inches of horizontal run. Flat roofs should be avoided.
- 36-2 The roof should include eaves that project and have a minimum overhang of 12 inches, including 4 inches for gutters.

Manufactured Homes



This manufactured home has been constructed with brick over the foundation and a front porch to give the appearance of permanency.

37 Giving an Appearance of Permanency

Design Principle

The manufactured home shall be installed on the site so as to give the appearance of a permanent home.

Rationale

Any running gear should be removed, and the manufactured home should be installed with the same level of permanency as a single-family home.

Design Guidelines

- 37-1 Any running gear, tongue, axles, and wheels should be removed at the time of installation.
- 37-2 The home should be installed on a permanent concrete or masonry and concrete foundation.
- 37-3 Siding, brick facing, or other high-quality exterior treatment should be used to fully cover the wheels and any gap beneath the bottom of the home. This exterior treatment should extend above the finished floor level of the home and be coordinated with the overall siding used on the home.

38 Selecting Suitable Materials

Design Principle

The materials used on the manufactured home shall be consistent with the materials found on site-built, single-family homes in the neighborhood.

Rationale

Every effort should be made to ensure that the materials used on the manufactured home are indistinguishable from those used on other homes in the neighborhood.

Design Guidelines

- 38-1 The siding used on the manufactured home should be consistent with siding on other homes on the block.
- 38-2 Brick or stone wainscoting are recommended where appropriate.
- 38-3 The roof should be surfaced with a material of one of the same types recommended for site-built homes, including composition, tile, or lightweight cement shingles.

This Page Intentionally Left Blank

Commercial Design Guidelines



Commercial Design Standards and Guidelines

GENERAL COMMERCIAL CONTEXT

The commercial areas in Oak Park display varied urban design patterns and architectural styles that reflect their unique historical influences. The more auto-oriented commercial form common from the mid-20th century to the present is found on portions of Broadway, Stockton Boulevard (including the corner of Broadway and Stockton Boulevard), and Fruitridge Road. Development in these areas is larger in scale, with larger lots and structures. Fruitridge Road and Stockton Boulevard have many commercial businesses that provide basic goods and services, such as groceries, gas, and dry cleaning.

A more traditional, pedestrian-oriented commercial development pattern is found on Broadway and a portion of Stockton Boulevard. Commercial buildings in these areas are typically constructed to the back of the sidewalk, with parking on the street or at the rear of the building. Two special commercial character areas have been identified that represent this type of development:

- Broadway Commercial Character Area
- Stockton Boulevard Commercial Character Area

These Commercial Design Standards and Guidelines address auto-oriented and pedestrian-oriented development patterns, with an emphasis on strengthening walkability, visual appeal, and human-scale design in both types of commercial areas.

Finally, although there is only limited commercial development along Martin Luther King Jr. Boulevard, the street includes two noteworthy civic buildings that contribute to the character of the street: the Oak Park Community Center and the Christian Brothers High School.



The Oak Park Community Center is painted with striking murals.

Introduction



John's Philly Corner is typical of several two-story commercial structures with hip roofs and wood lap siding.



The historic Guild Theater on 35th Street is an exceptional example of the brick structures typical of this area.



The W.I.G.S. Thrift Shop is constructed primarily of glass and steel.

BROADWAY COMMERCIAL CHARACTER AREA

The Broadway Commercial Character Area includes portions of Broadway and 35th Street that represent the oldest commercial buildings in Oak Park, dating to the late 19th and early 20th centuries.

Commercial buildings in this area are typically one or two stories, with some buildings that are grand in scale and mass. Because Broadway bisects the area at an angle to other streets, many commercial buildings have entries at the corner of a triangular lot. (Note Paine's Drugstore to the right, or the W.I.G.S. Thrift Shop on this page.)

Architectural styles are diverse, representing examples of Classical, Neoclassical, or California Mission Revival, and various forms of vernacular architecture. Brick and stucco are the most common exterior materials. Terra cotta can be seen on the U.S. Bank building, and wood lap siding has been used on several buildings. Some of the best historic structures, such as the U.S. Bank building and the Guild Theater, have been carefully renovated and can set the tone for high-quality design in this area.

Several examples of Streamline Moderne can be seen on the north side of Broadway. The building that currently houses the W.I.G.S. Thrift Store (constructed of glass and steel) and the Paris Bakery (constructed primarily of concrete) are distinct examples.

Buildings on the north side of Broadway also range from simple concrete warehouses to one-story stucco, brick, or concrete block commercial structures. There are also a number of vacant lots on the north side of Broadway, several of which are triangular in shape. As these lots are redeveloped, it will be important for the facades and primary entries of infill structures to face Broadway and take design cues from existing structures in the vicinity.

Because brick is the most common material, as reflected in several fine local architectural examples, it is the preferred material for infill structures located directly on Broadway. Other infill structures facing Second and Fourth Avenues and 33rd through 37th Streets may more flexibly interpret the common architectural styles in the area.

**BROADWAY COMMERCIAL CHARACTER AREA MAP,
WITH SELECTED EXAMPLES**

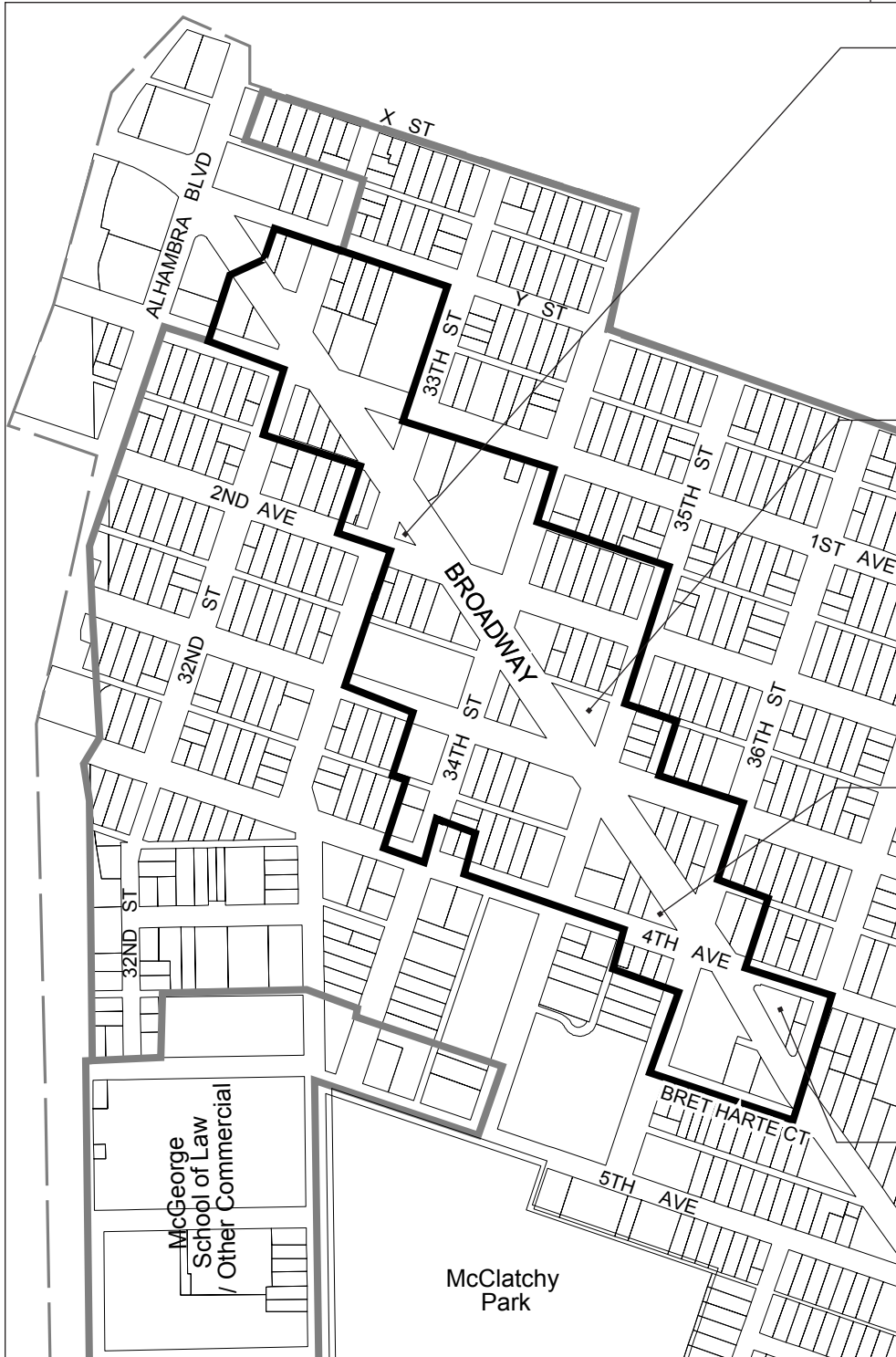

Paine's Drug Store



Empty lot with warehouses behind it



McDonald Plumbing, Heating and Air



Paris Bakery

Introduction

STOCKTON COMMERCIAL CHARACTER AREA

The Stockton Commercial Character Area is located on Stockton Boulevard between Eighth and 14th Avenues, with the majority of existing commercial structures concentrated on the west side of the street.

The area is distinguished by small commercial structures located at the front of the lot line adjacent to the sidewalk, with parking at the side or rear of the buildings. The majority of commercial buildings in this area are one story, with simple, flat rooflines and entries facing the street. Buildings displaying California Mission Revival influences are common, with a number of vernacular commercial structures and the Colonial Theater representing Streamline Moderne.

The University of California, Davis, maintains its C.A.A.R.E. facility (a pediatric care center) on Eighth Avenue and Stockton Boulevard. The C.A.A.R.E. facility is an interpretation of California Mission Revival architecture, with smooth stucco walls and tile roofing.

The Colonial Theater, located at 10th Avenue and Stockton Boulevard is the most notable example of Streamline Moderne in the vicinity. The theater has striking vertical signage, blue tiles that extend to other buildings on the block, and white stucco walls that contribute to the building's significance as a visual landmark for the area.

A number of simple vernacular structures mix elements of the Mission and Streamline Moderne styles, using stucco as the primary siding material, accented with tiles, glass block, or brick. Windows are typically rectangular storefront windows facing the street.

As redevelopment progresses, the City will balance preservation of the area's existing buildings with the goals of redevelopment. Some of the smaller commercial buildings may be suitable for renovation into clothing boutiques, restaurants, coffee shops, bookstores, or similar businesses. However, in order to encourage redevelopment, it may be necessary to aggregate some of the parcels and replace associated buildings with new construction. All renovation of existing structures and new infill construction in this area should reinforce the area's key features, and architectural design should be contemporary interpretations of local styles.



The Colonial Theater is a notable example of Streamline Moderne on Stockton Boulevard.



California Mission Revival is a common architectural style in the Stockton Commercial Character Area.

**STOCKTON COMMERCIAL CHARACTER AREA MAP,
WITH SELECTED EXAMPLES**



The U.C. Davis C.A.A.R.E. facility displays California Mission Revival design elements.



Inflation Tires is a unique example of Streamline Moderne.



These businesses adjacent to the Colonial Theater share its blue accent tiles.



This commercial building is typical of several in the vicinity that have not been redeveloped.



Maria's Mexican Grill

Commercial

SITE DESIGN

This section provides direction for the site design of new commercial development and the renovation of existing structures. Effective site planning techniques should create a unified commercial environment that reflects the character and history of the area.

The major principles of commercial site design are intended to:

- create a comfortable and welcoming pedestrian environment;
- enhance the vitality of the commercial district;
- create a distinctive character and sense of place for commercial streets; and
- clearly define the public realm with a “streetwall” of commercial buildings that frame the street.



A commercial district with a traditionally designed “streetwall” of buildings



A pedestrian-oriented commercial district can include street trees, cafe seating, and wide sidewalks.

39 Building Orientation, Setbacks, and Build-to Lines

Design Principle

Buildings shall be constructed to the front of the property line behind the sidewalk, with allowable variations in the setback to provide for café seating, plazas, and other additions to the public realm.

Rationale

Commercial buildings in traditional urban areas have typically been built to the front of the property line behind the sidewalk, creating a line of buildings with a consistent “streetwall” that supports a strong relationship between the building, the sidewalk, and the street. This streetwall should be reinforced by new construction and additions. The streetwall may be varied to create usable public spaces such as outdoor café dining and small plazas with seating.

General Design Standards and Guidelines

- 39-1 Buildings should be constructed to the front of the property line and from side property line to side property line.
- 39-2 Facades that front onto a public street should be built parallel or nearly parallel to the public right-of-way.
- 39-3 A portion of the front setback may be increased by as much as 15 feet, if that setback is used as public space such as outdoor restaurant seating or a courtyard with public access. A minimum of 60% of the front facade should be constructed up to the front setback.
- 39-4 Buildings at corners may be set back to create corner entries or “chamfered” entries.
- 39-5 New buildings should provide an appropriate setback to allow rear- and side-yard facing windows on existing buildings to have access to light, air, and usable space between buildings.

Broadway Commercial Character Area Design Guidelines

- 39-6 Broadway intersects north/south streets at an angle, creating triangular or oddly-shaped lots that pose a challenge to creating a traditional streetwall. In these instances, the front facade of the building must be designed to face Broadway, which is the primary pedestrian street.

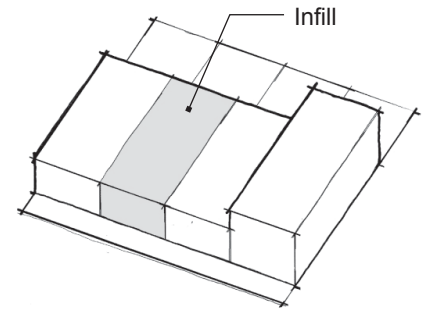

New construction and additions should be built to the back of the sidewalk or at the front of the property line.

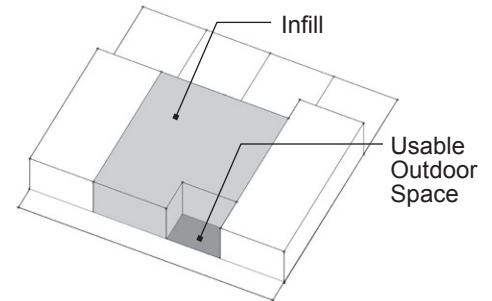

New construction and additions may increase a portion of the front setback if designed as usable outdoor space.

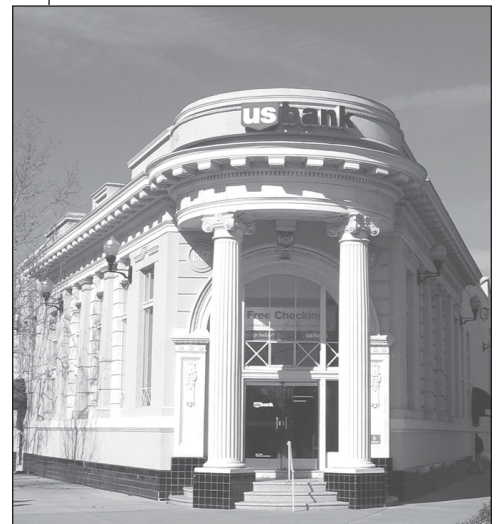

The U.S. Bank building on Broadway was designed for a triangular lot.

Commercial

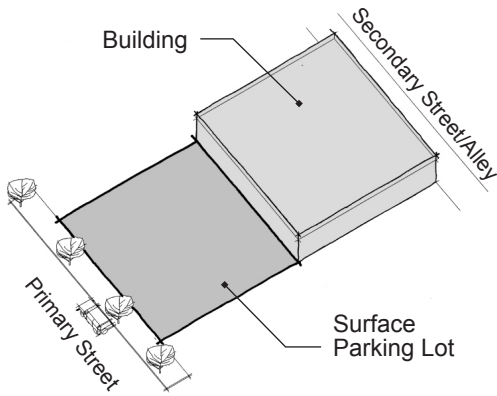

Parking should not be located at the front of the building.

40 Parking

Design Principle

Parking areas shall provide vehicular access without compromising pedestrian accessibility and the character of the public realm on primary commercial streets. Parking lots shall be placed at the rear of the building, when feasible, to not obstruct views of the building's front facade from the street.

Rationale

Adequate and accessible parking areas are important to the viability of commercial districts. However, large surface parking lots fronting the street can create the appearance of a vacant and uninviting area that detracts from the visual continuity of the commercial streetwall and impedes and discourages pedestrian traffic. Smaller parking lots located at the rear or sides of commercial buildings are a recommended alternative.

Parking Lot Design Standards and Guidelines

- 40-1 Parking lots should be located behind the commercial frontage on major pedestrian streets, such as Broadway and Stockton Boulevard. Where parking at the rear of the building is not possible, it may be located in an interior side lot. Parking at the front of the building or corner lots is highly discouraged.
- 40-2 Large surface parking lots should be avoided in favor of several smaller parking lots.
- 40-3 Driveways into parking lots should be located on side streets, where feasible. Access to parking on major pedestrian streets should be minimized.

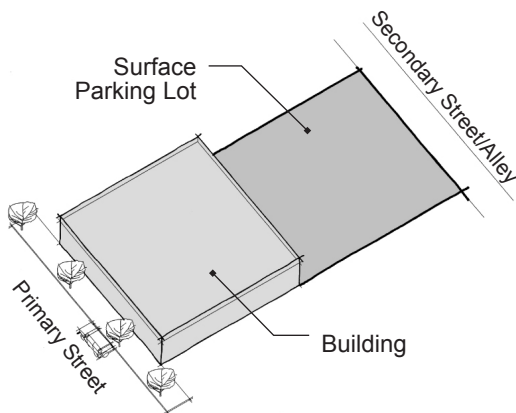

Parking should be unobtrusive to encourage an active street life and a comfortable pedestrian environment. Parking should be placed behind, under, or on the side of buildings.



The facade of this parking structure has been designed to complement the adjoining commercial building.

Commercial

- 40-4 Parking lots should include signage and well-designed locations for ingress and egress that reduce conflicts with pedestrian movement.
- 40-5 Access to commercial buildings from rear or side parking lots or alleys should be well maintained and kept clear of obstructions.
- 40-6 Parking lots, driveways, and walkways should be connected with those of neighboring sites to consolidate traffic and minimize conflicts with pedestrian and automobile circulation.

Parking Structure Design Standards and Guidelines

- 40-7 Parking structures are encouraged, where financially feasible.
- 40-8 Parking structures that are located on primary commercial streets should be designed with retail, office, or other uses at the street level to avoid monotonous blank walls.
- 40-9 Parking structures should be designed with architectural features that complement existing commercial, office, and mixed use buildings in the vicinity.
- 40-10 Parking structures should be designed to incorporate passive safety design features to create a secure facility. The use of glass for pedestrian stairways and adequate interior lighting are encouraged.
- 40-11 Entry and exit ramps should be located mid-block or toward service areas rather than facing primary pedestrian streets.
- 40-12 Pedestrian entry and exit features should be clearly marked and open onto primary pedestrian streets and routes.

Stockton Commercial Character Area Design Guidelines

- 40-13 Parking should be located behind commercial buildings or on the street to maintain the traditional streetscape.

Broadway Commercial Character Area Design Guidelines

- 40-14 Parking on triangular lots must be designed so that the building occupies the majority of the frontage on Broadway. On-street parking may be used as a portion of the parking requirements for triangular lots.



Parking at the side of a renovated commercial building on Stockton Boulevard



Sign in the window of the Bayside Cafe on Stockton Boulevard

Commercial

ARCHITECTURAL ELEMENTS

Architectural design guidelines address the exterior of buildings and their relationship to the surrounding built context. It is paramount to ensure that the design of the building complements the community setting and character and contributes to the public realm. Architectural design should promote commercial buildings that are:

- visually welcoming from the primary pedestrian street;
- similar in mass and scale to other commercial buildings in the area; and
- constructed of high-quality materials that will contribute to the longevity of the building.



High-quality materials and human-scale design are exemplified by this older building in the Broadway Commercial Character Area.

41 Building Height, Massing, and Scale

Design Principle

The size and scale of commercial buildings shall be compatible with existing development in commercial districts.

Rationale

To ensure compatibility with existing development, new development should appear similar in massing and scale, and the heights of new buildings should generally fall within the height range of existing buildings on the block. Corner sites offer a special opportunity for providing additional building height and can serve as anchor sites for a block.

General Design Standards and Guidelines

- 41-1 New, higher buildings can reinforce the established building heights along a block by stepping back upper floors that are above the average building height along the street.
- 41-2 A building that is larger than the average of buildings on the same block should break up the mass of the structure with articulation of the structure into smaller components and the creation of multiple surfaces.
- 41-3 Appropriately scaled doors, windows, awnings, and detailing can reduce the appearance of mass.
- 41-4 Buildings on corner lots provide an opportunity for construction of structures that exceed the average height on the block and can serve as anchor points.
- 41-5 Building heights should not block important view corridors into the neighborhood.

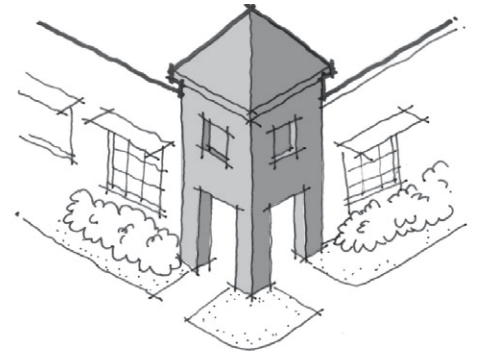

Building entries at corners should address both sides.

Broadway and Stockton Boulevard Commercial Character Area Design Guidelines

- 41-6 The floor-to-floor height used in older, established buildings shall be maintained in new construction.



New construction and additions that deviate from the typical proportions of height, width, and depth may appear out of scale with existing buildings.

Sustainability Guidelines

- 41-7 Massing design should provide opportunities for daylighting and solar panels. Glazing should be located predominantly on the north and south sides of the structure, with glazing on the west side minimized unless the west side is also the street side.



New construction and additions shall respect the typical proportions of height, width, and depth.

Commercial

42 Building Facades

Design Principle

Building facades shall be designed to create visually interesting buildings that offer variety along the commercial street.

Rationale

Building facades provide the interface between the built environment and the public realm. Historically, commercial districts have consisted of buildings that are one or two stories in height and cover entire lots. This pattern creates a regular rhythm of building mass and streetwalls. A streetwall of varied building facades is visually appealing and enhances the pedestrian environment. Blank walls at the ground floor level are unattractive and uninviting and should be avoided. Instead, elements should be used to create visual interest, including awnings and canopies, windows, doors, trellises, detailed parapets, or arcades.

In recent decades, new buildings have increased in size and scale, creating greater challenges to creating human-scale commercial environments. Therefore, appropriate architectural elements, such as window openings, commercial displays, frequent building entries, ornamentation, awnings and canopies, contribute to a pleasant urban streetscape.



Avoid expansive blank walls along streets.

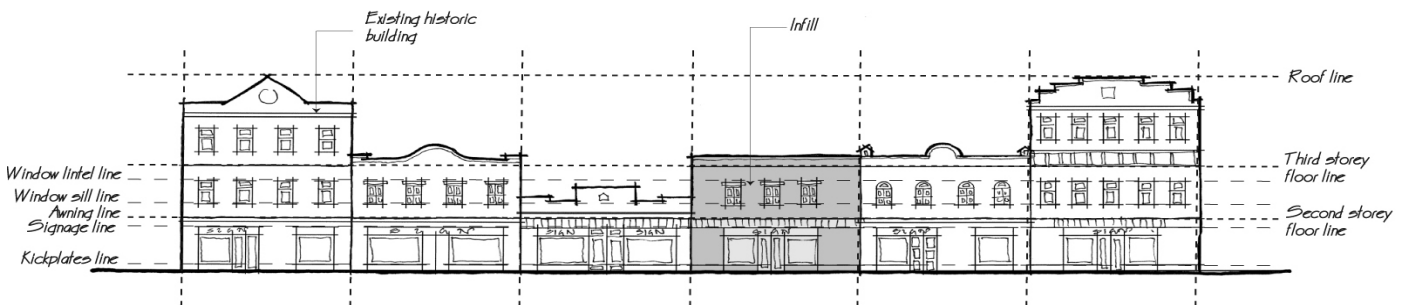

New construction, additions, and alterations should draw from existing architectural features.

Commercial

General Design Standards and Guidelines

- 42-1 Doors, windows, floor heights, cornice lines, signage, and awnings should be appropriately scaled to reduce the mass of buildings as experienced at the street level.
- 42-2 The primary facade of a building must face a public street and include an entry that is accessible from the street, where feasible.
- 42-3 The main entrance of a building without a street edge facade should open directly onto a publicly accessible walkway. This walkway should connect directly to an adjacent street sidewalk.
- 42-4 A building facade facing the street should be lined with windows, entries, and openings that provide indoor and outdoor views to the public rights-of-way and sidewalks. Continuous blank-wall surfaces are not allowed.
- 42-5 Architectural features, such as display windows, pilasters, lattices, and alcoves for the product display, can provide visual relief on buildings that cannot achieve continuous openings along the street and sidewalk.
- 42-6 Facades can also be articulated with insets, partial setbacks, and small pedestrian plazas, (see Section 39, "Building Orientation").



A corner facade on Broadway



This building is a contemporary interpretation of traditional design.

Commercial

- 42-7 Solid roll-down security grates shall not be used on the exterior of the building; however, they may be placed on the interior of storefront glazing or entry doors.
- 42-8 Highly reflective or dark tinted glass should be avoided.
- 42-9 Street facades of commercial buildings in areas of predominantly older buildings must have a ground floor base of a durable material, such as stone, tile, or certain types of finished concrete, where feasible.
- 42-10 Building facades should be designed to create a recognizable “base” and “top.” Building bases and tops can be created with variations in:
- building wall thickness;
 - use of special materials;
 - changes in colors and materials on window trim;
 - cornice treatments;
 - roof overhangs with brackets; and
 - use of ornamental building lines.



New construction and additions are encouraged to use horizontal elements to create a “top” and “base” that give definition to the building and break down its elements to a more human scale.

Broadway Commercial Character Area Design Guidelines

42-11 The designs for elements such as solid kickplates, transoms, clerestory windows, individual punched window openings in the upper floors, and sign bands must should retain the traditional scale and character of older buildings on the block, where feasible.

Design Guidelines for Mixed-Use Buildings

42-12 Mixed-use development combines commercial development with other uses, such as office and residential. When mixed-use development is vertical in form, the commercial and office professional uses should be on the first story, with residential above. The first story should be designed as described in Guideline 42-4, with a large percentage of windows, doors, and other transparent surfaces. Upper stories should have a larger percentage of opaque surfaces, which can be articulated with windows, balconies, and patios.



This mixed use building has a strong corner treatment, a clearly defined base, and an articulated facade.

Commercial

43 Additions

Design Principle

Additions shall be consistent with the architectural style, massing, proportions, and scale of the existing building.

Rationale

Additions should be designed as an adjunct that does not visually interfere with the original structure. The architectural details on the addition should be designed to reflect those on the original building.

General Design Standards and Guidelines

- 43-1 An addition should respect, but be subordinate to, the design of the original building, and should be designed so that the form of the original structure can still be recognized.
- 43-2 An addition should not alter or destroy the architecturally defining features of the original building, such as original porches, columns, railings, stairs, windows, doors, and roof and eave forms.
- 43-3 Large additions should be broken down into smaller, varied components that relate to the scale and massing of the original structure.
- 43-4 An addition should be compatible with the overall character of the property, block, and neighborhood.
- 43-5 New additions should be set back from the primary facade, especially if the additions are taller than the original building.

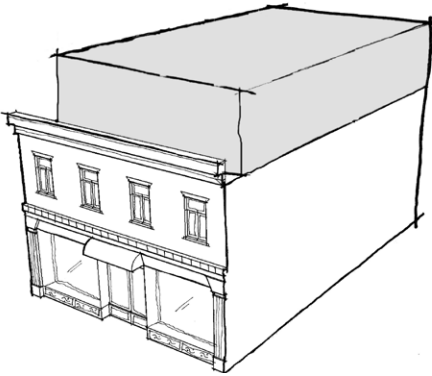

Addition to the top of the structure, with a second-story setback from the existing facade

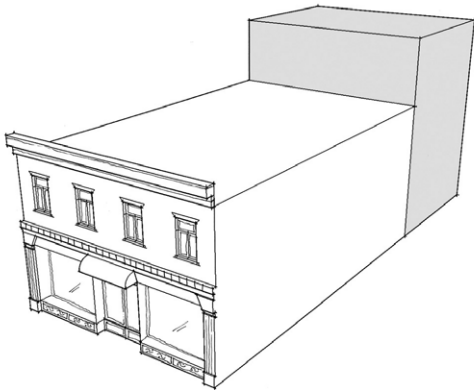

Addition at the rear of the original structure

44 Roof Forms

Design Principle

The roof forms of new development shall reflect the rooflines of established commercial structures.

Rationale

Flat rooflines are typical of much established commercial development. New commercial development should try to emulate this existing form to maintain the character of the neighborhood. However, variation in roof shapes can be desirable if compatible with existing buildings on the block.

General Design Standards and Guidelines

- 44-1 Articulated facade surfaces with multiple rooflines are encouraged for taller buildings to avoid an appearance of mass and to add interest.
- 44-2 One-story buildings should use simple roof forms.
- 44-3 Special roof forms on corner buildings are encouraged to help accentuate the corner location.
- 44-4 Materials that are used in existing buildings, or that are visually compatible with materials in existing buildings, should be used in the construction of new roofs.

Broadway Commercial Character Area Design Guidelines

- 44-5 Buildings in this area sometimes have flat roofs with decorative parapets and cornices, particularly on buildings designed in the California Mission Revival style of architecture. These decorative roof elements are encouraged on infill construction if appropriate to the design of the building.

Sustainability Guidelines

- 44-6 The addition of photovoltaic solar panels is suggested to reduce energy use.
- 44-7 The use of “cool roof” materials and or “green” roofs is encouraged to reduce energy use, heat transmission, and stormwater runoff and improve the water quality of stormwater runoff.
- 44-8 Roofing options that include recycled content are encouraged.

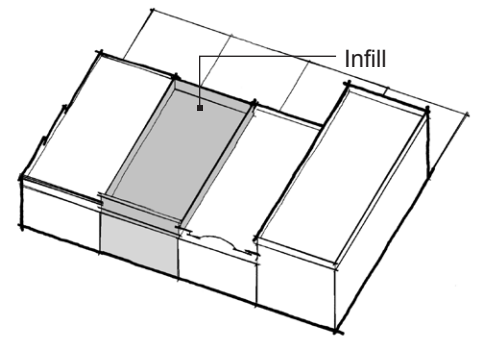

This infill project has a flat roof similar to other nearby existing structures.

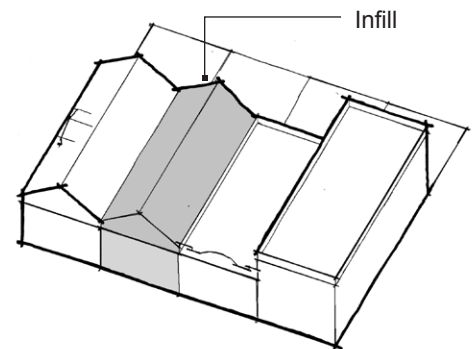

An infill project with a pitched roof in areas where nearby buildings have pitched roofs is acceptable.



The Brick House in the Broadway Commercial Character Area has a typical flat commercial roof.

Commercial

45 Entry Features

Design Principle

The entry features of commercial buildings shall be clearly visible to pedestrians, with a defined relationship to the street and sidewalk.

Rationale

A recessed entry helps to break up the massing of a building and makes the threshold immediately apparent to pedestrians. Decorative features, such as awnings, canopies, lighting, and signage, can also be used to clearly define and articulate an entryway.

General Design Standards and Guidelines

- 45-1 Primary entries should be located on major sidewalks to provide clearly visible pedestrian access.
- 45-2 The size of the entry should be proportional to the building.
- 45-3 Secondary entries may be located at the side or rear of the building to provide access from parking areas.
- 45-4 Entries should be clearly defined with signage and architectural details.
- 45-5 In mixed-use buildings, the entrance to residential uses on the second story should be clearly defined and easily approachable from a public street or sidewalk.

Broadway Commercial Character Area Design Guidelines

- 45-6 Traditional entries are often inset and embellished with details such as sidelights, transoms, columns, and pedimental trim. Buildings in the commercial character area should incorporate such details into new infill buildings with traditional design.

Stockton Commercial Character Area Guidelines

- 45-7 Entries should suit the style of architecture in infill development. Entries in buildings designed in the California Mission Revival style, for example, can be arched and ornamented with fluted and scrolled detailing.



A traditional recessed entry with stained glass transom.



This recessed entry shows the oversized wooden window framing found on some older buildings on Stockton Boulevard. (For a view of the entire building, see page 70.)

46 Windows and Doors

Design Principle

The proper placement and design of windows and doors shall be used to create visual interest in commercial buildings and contribute to the stylistic coherence of development along the street.

Rationale

The placement of windows and doors along a street frontage is one of the best methods of creating visual interest into a building. Storefront windows at the street level can be used to allow pedestrians to see into the structure, and individuals inside the building to view the street, improving visual surveillance of the area outside the building and increasing security.

General Design Standards and Guidelines

- 46-1 Windows, entries, and doors should occupy most of the wall surface on the ground floor.
- 46-2 Building openings, such as windows and doors, should maintain the proportions and spacing of other openings on the block.
- 46-3 Headers, trim, and sills of windows of new buildings should be well articulated in design, dimensions, and profiles.
- 46-4 Windows should be made of clear glass to allow pedestrians to see into the structure. Use of mirrored or dark tinted glass is not allowed.
- 46-5 Windows with authentic mullions that contain true divided lights are encouraged.



Windows at the U.C. Davis C.A.A.R.E. facility on Stockton Boulevard reflect Mission architectural influences.



Windows should occupy most of the first floor facade of the building.

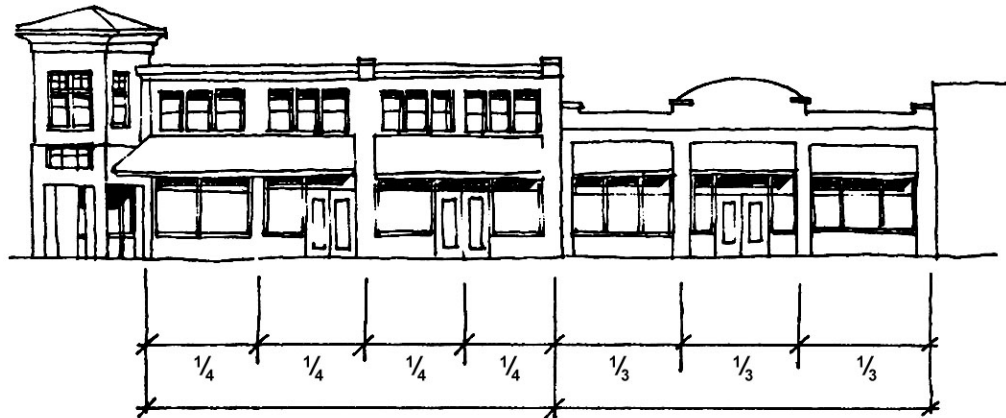

Building openings should maintain the proportions and spacing of other openings on the block.

Commercial



Commercial doors should primarily be constructed of transparent glass.

- 46-6 Doors should primarily be constructed of transparent materials, such as panels with glass, full-light glass, or glass panes in a wood or metal frame.
- 46-7 Security bars on the outside of commercial windows are highly discouraged.

Broadway Commercial Character Area Design Guidelines

- 46-8 Upper floors must use vertically proportioned window openings similar in form to those used in older buildings, where feasible.
- 46-9 The spacing of windows must follow the facade patterns of older buildings on the block, where feasible.

Stockton Commercial Character Area Design Guidelines

- 46-10 Glass block, reflecting Streamline Moderne influences, can be used in new infill in small amounts.
- 46-11 Sturdy wood window frames (2- to 3-inch typical) have been used in some vernacular commercial architecture and are desirable for new infill construction.
- 46-12 Horizontal bands of vertical windows are common in Streamline Moderne buildings.

Sustainability Guidelines

- 46-13 Skylights are encouraged to daylight the interior floor area, thus reducing energy use and creating a more pleasant retail/commercial environment.
- 46-14 Prismatic glazing is encouraged to increase the energy efficiency of skylights.
- 46-15 Windows should be oriented to maximize controlled daylighting from the south and north.
- 46-16 The use of insulating glazing such as LoE² is encouraged to increase energy efficiency.



Upper floor windows in the Broadway Commercial Character Area should be vertically proportioned.



Glass block can be found in some buildings on Stockton Boulevard.

47 Color

Design Principle

Color shall be used in a way that complements the surrounding structures and adds to the liveliness and character of commercial districts.

Rationale

The use of pre-approved colors can lead to a repetitive streetscape that is lacking in distinction and interest. Matching existing color schemes can also lead to blocks, or an entire district, in one repetitive color. In general, the major design principle in the selection of building colors is to be compatible with, but not identical to, surrounding development.

General Design Standards and Guidelines

- 47-1 Colors should be compatible with those of the neighboring buildings.
- 47-2 Creative use of colors is encouraged. Unique or unusual color schemes will be considered on a case-by-case basis during the design review process.
- 47-3 Building colors that complement natural materials, such as brick, stone, tile, and terra cotta, are encouraged as a primary building color. Building colors should avoid more intense colors as a primary design element.
- 47-4 Contrasting accent colors are encouraged for architectural details, awnings, and entrances.
- 47-5 Colors should be selected with consideration for the orientation of buildings. Colors on south- and west-facing facades will often appear warmer, due to sun exposure than the same colors on the north or east sides.
- 47-6 Fluorescent, neon, or “dayglo” colors are strongly discouraged as the primary color.

Broadway Commercial Character Area Design Guidelines

- 47-7 Colors used in the commercial character area should reflect the more muted colors that would have been used in the area traditionally.

Stockton Commercial Character Area Design Guidelines

- 47-8 Structures on Stockton Boulevard can tolerate a colorful palette that reflects the variety of development on that street.

Commercial

Typical Materials in the Broadway Commercial Character Area

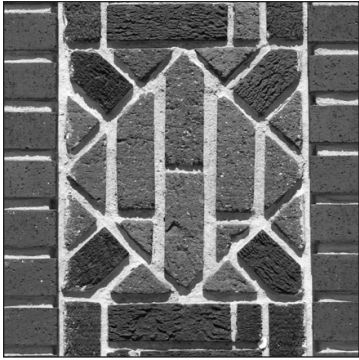

Brick of varied textures and patterns



Brick with molded concrete



Terra cotta detailing



Stucco



Wood lap siding

© 2005 JupiterImages Corp.

48 Materials

Design Principle

Buildings shall be constructed of high-quality materials that will promote the longevity of the structure and provide a pleasing appearance as the materials age.

Rationale

High-quality finish materials promote the longevity of a building and add to its character, particularly on the ground floor, where people are most likely to come in contact with the building and can easily see and touch the materials.

General Design Standards and Guidelines

- 48-1 Use of materials commonly found on other commercial buildings in Oak Park is recommended.
- 48-2 Durable, solid facing materials should be used.
- 48-3 Use of the following materials is not allowed:
 - vinyl or grooved plywood siding
 - sprayed-on, textured stucco
 - raw, raised grain, or rough-sawn wood

Commercial

48-4 Materials used in new buildings should be selected from the established range of exterior wall materials used in older buildings in the area.

48-5 Wood should be milled, with a smooth, painted finish.

Broadway Commercial Character Area Design Guidelines

48-6 Brick is the preferred material for commercial buildings in the commercial character area. However, terra cotta, smooth stucco and wood lap siding may also be used.

Stockton Commercial Character Area Design Guidelines

48-7 Buildings in the commercial character area may be constructed of smooth stucco or brick, with tile, glass, and steel accents.

Sustainability Guidelines

48-8 The use of materials that include recycled content is encouraged to reduce waste.

Materials found in Stockton Commercial Character Area



Stucco



Brick



The ticket booth at the Colonial Theater, with examples of glass block and tile

Commercial



Canvas awning

49 Canopies, Awnings, and Arcades

Design Principle

When incorporated into a commercial building, canopies, awnings, and arcades shall be made of high-quality components that complement the overall design, colors, and materials of the building.

Rationale

Canopies, awnings, arcades, and overhangs are traditional commercial design elements that articulate the building facade and create variety and interest at the street level. They also serve the practical purposes of providing space for signage of commercial uses, shading windows during the summer to reduce energy use, and providing shade and weather protection for pedestrians, encouraging walking instead of auto use.

General Design Standards and Guidelines

- 49-1 Canopies, awnings, arcades, and overhangs are encouraged over window displays and entries along public sidewalks on the ground floor of commercial buildings.
- 49-2 Canopies, awnings, and overhangs that project into the public right-of-way are subject to a City revocable encroachment permit. Contact the Building Division of the City Development Services Department for more information.
- 49-3 Canopies, awnings, and arcades should be designed with respect for the proportions of the building in terms of size, shape, and placement unless a unique architectural style encourages something different.
- 49-4 Canopies and awnings should fit within individual bays or structural divisions of the building facade rather than extending beyond a single bay, unless the building structure dictates an alternative placement.



Steel overhangs help to articulate commercial entries, offer shade and add architectural interest to the building.

- 49-5 Use of a continuous awning for the windows in the upper floors is discouraged. Each window should be articulated with an individual canopy or awning, with awnings extending no more than halfway down the window. The color and style should complement ground-level awnings and canopies on the same building.
- 49-6 Self-supporting canopies and awnings are recommended.
- 49-7 A variety of solid and striped colored awnings may be considered.
- 49-8 Brightly colored awnings should be compatible with the colors used on the main building. Uncolored or light-colored canvas awnings may be appropriate for dark and north facing facades to allow daylight to filter through to storefronts and second-story windows.
- 49-9 Canvas, fire-resistant acrylic, and metal are preferred materials for awnings. Vinyl, plastic, plasticized fabric, and fiberglass awnings are strongly discouraged.
- 49-10 Canvas awnings often fade and deteriorate over time. Canvas awnings will need regular maintenance and periodic replacement.
- 49-11 Awnings, decorative roofs, and miscellaneous entry features may project into the front public right-of-way, provided that they are not less than 8 feet above the sidewalk.
- 49-12 Canopies and awnings should only be internally illuminated where appropriate to the architectural style of the building.
- 49-13 Canopies and awnings should be designed to provide window shading to reduce energy use.

Broadway Commercial Character Area Design Guidelines

- 49-14 Canopies and awnings must not cover historical decorative ornaments, cornices, transoms, or other architectural elements of the facade.



Steel awnings may be used in the Stockton Commercial Character Area.

Commercial

Signage suitable for the Broadway Commercial Character Area



Signage applied to a glass window



Wall-mounted, projecting "blade" signage



Signage printed on an awning

50 Signage and Graphics

Design Principle

Building identification signs and graphics shall enhance the appearance of the building and contribute to the overall character of the street, while minimizing the appearance of clutter.

Rationale

Attractive, artistic, well-proportioned, and carefully located signs can enhance the character of commercial districts. Signage should be used for information, direction, and wayfinding, and not for advertising specific products. Signage should enhance the character of existing older buildings, and can help new development to be compatible with existing development.

General Design Standards and Guidelines

- 50-1 All commercial signage is subject to a City of Sacramento sign permit. Contact the Building Permits Division of the City Development Services Department for more information.
- 50-2 Signage can be wall-mounted, projecting, combined with awnings, or placed on windows. Hanging signs with projecting lettering are encouraged.
- 50-3 Cabinet and pole signage are discouraged.



Signage for multiple tenants

Commercial

- 50-4 Materials and colors of signage should be compatible with those of the building as well as adjoining buildings.
- 50-5 Signage should be modest in scale and appearance, and should complement, not overpower, the building.
- 50-6 Signage must not obscure important architectural elements, such as windows, cornices, or decorative details.
- 50-7 Individual shop signs in a single storefront should relate to each other in design, size, color, lettering style, and placement on the building.
- 50-8 Buildings with multiple tenants should have a common signage program and include a multiple directory.
- 50-9 Signage lighting should not result in glare or light spillover to other properties.

Broadway Commercial Character Area Design Guidelines

- 50-10 Painted wood and metal are the preferred materials for signs. Internally illuminated signs should be avoided on older buildings, except for neon signage that is used in the appropriate context for buildings constructed after 1930.

Stockton Commercial Character Area Design Guidelines

- 50-11 Creative use of signage with neon lighting is appropriate when complementary to the design of the building.

Signage in the Stockton Commercial Character Area



Historical signage can contribute to the character of the commercial district.



Lettering affixed to the facade of the building is appropriate for Stockton Boulevard.



Signage applied to a window on Stockton Boulevard

Commercial

Lighting in the Broadway Commercial Character Area



The Guild Theater in Oak Park uses subtle neon lighting.

51 Lighting

Design Principle

Lighting fixtures shall be designed to complement and enhance the architectural style of the building and shall be compatible with the character of the area.

Rationale

Lighting on buildings and sites can have a dramatic effect on the mood, quality, and character of commercial districts. The color, intensity, and types of lighting used on buildings and in landscaping contributes to the character of commercial areas.

Adequate and carefully placed lighting can improve the safety and security of a site, adjacent streets, and surrounding properties. Visibility at intersections and pedestrian crossings can also be enhanced with appropriate lighting.

General Design Standards and Guidelines

- 51-1 Building lighting should relate to the style and character of lighting on the whole site.
- 51-2 Use of neon, marquee lighting, and other specialized lighting is appropriate in some areas, and may be used for restaurants and entertainment uses.
- 51-3 Specialized lighting is appropriate for building features, entries, building towers, and other architectural elements.



Gooseneck lighting can be used on both older buildings and contemporary architectural interpretations.

Commercial

- 51-4 Lighting should provide even illumination. Flashing, pulsating, rotating, or otherwise moving light fixtures are not appropriate.
- 51-5 Lighting fixtures must not obscure major architectural features.
- 51-6 Lighting should not direct unwanted glare toward adjacent residential or other sensitive areas. Downlighting and specialized fixtures that reduce sky-lighting and glare are encouraged. Particular care should be taken to eliminate light spillover and glare from pedestrian pole lighting through the use of a solid top or reflection device.
- 51-7 Pedestrian areas should be lighted by pole- or bollard-type fixtures that are not more than 14 feet in height for pole lighting, or 3 feet in height for bollards.

Broadway Commercial Character Area Design Guidelines

- 51-8 Lighting should represent traditional forms.

Stockton Commercial Character Area Design Guidelines

- 51-9 Contemporary lighting may be used when appropriate to the design of the building.

Sustainability Guidelines

- 51-10 Compact fluorescent bulbs and photocell sensors are encouraged to achieve energy efficiency.



Contemporary lighting is appropriate for buildings in the Stockton Boulevard Commercial Character Area.

Lighting suitable for the Stockton Commercial Character Area



Pedestrian pole lighting with a solid top eliminates light spillover and glare.

Commercial

52 Services and Utilities

Design Principle

Service and utility areas, including loading docks, storage areas, mechanical systems, and trash bins, shall be screened from view and integrated into the design of the project.

Rationale

Although necessary and functional aspects of commercial districts, service areas, loading docks, delivery areas, and mechanical equipment can be unsightly and noisy and may detract from the quality of the urban environment. Functional service areas of buildings should receive the same design attention and consideration as more public spaces and should be carefully placed and screened to reduce noise and visual blight.

General Design Standards and Guidelines

Service Areas and Loading Areas

- 52-1 Service areas, including loading docks, storage areas, and trash bins, should be screened from adjoining walkways.
- 52-2 To the extent feasible, loading areas shall be located and designed to minimize their visibility from public areas and adjacent properties. Loading areas shall be accessible from side streets, interior parking garages, or the rear of buildings rather than from the fronts of buildings.



The rear of this commercial building has been carefully screened.

- 52-3 Landscaping and decorative walls and fences should be used to screen mechanical equipment, loading areas, and other service areas.
- 52-4 Where feasible, loading areas should be functionally separated from parking and pedestrian walkways for safety and to provide convenient access for delivery trucks.

Mechanical Systems

- 52-5 Mechanical equipment, such as air conditioning units, pipes, ducts, vents, access doors, meters, transformers, and other building systems equipment that produce noise, exhaust, or visual unsightliness, should be located away from pedestrian ways.
- 52-6 All such equipment should be screened or hidden from public view in a manner consistent with the character of the building and the surrounding district.
- 52-7 Rooftop and ground mounted mechanical equipment and trash storage areas should be screened from view from adjoining properties and public rights-of-way.

Trash Enclosures

- 52-8 All outdoor trash and garbage containers should be located at the rear of lots away from public view and screened with solid, decorative walls that match the design of the primary structure. Where possible, trash enclosures should not be located along the pedestrian ways and streets.

Sustainability Guidelines

- 52-9 Where feasible, heating, ventilation, and air conditioning units should be placed on the north side of the building (if not the street side) to shade the units and minimize energy consumption.

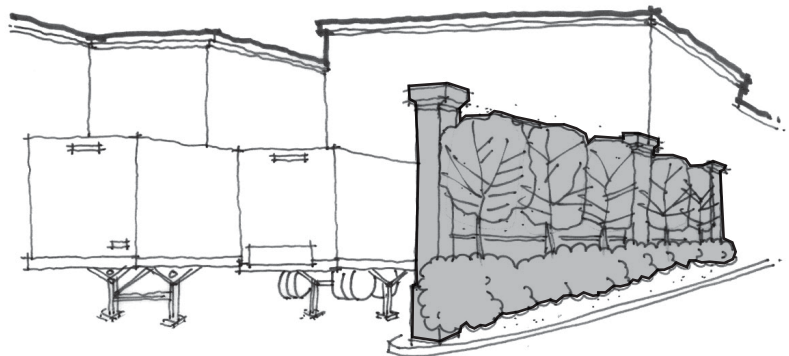

Service/loading and trash areas should be screened from view with landscaping, walls, or other structures.

STREETSCAPE GUIDELINES

The design of the streetscape should address the relationship between commercial buildings and the public realm by providing such amenities as street trees, street furniture, landscaping, and paving. A successful streetscape should foster a sense of place and feelings of community pride and ownership. It can also enhance the value of commercial properties. Elements such as street trees and street furniture should contribute to a pleasant, walkable environment. The streetscape design in the neighborhood should also support public social interaction and enhance the vitality of the commercial district.



Street trees soften the appearance of a commercial street.

53 Parking Lot Design

Design Principle

Parking lots shall be screened from the street and nearby sidewalks and provide shade to parked automobiles.

Rationale

Parking lots should be adequately screened with fences, walls, and landscaping. Trees and landscaped areas incorporated into parking lots can help to soften paved areas, reduce heat during the summer months by providing shade, and help to filter pollutants from the air.

General Design Standards and Guidelines

- 53-1 Surface parking lots adjacent to public sidewalks should be screened with appropriate design elements, such as fences, walls, and landscaping.
- 53-2 To promote visual surveillance of parking lots, screening materials should not block views lots from passing cars.
- 53-3 Pedestrian routes through parking lots should be clearly designated with paving and landscaping.
- 53-4 Use of a trellis-style structure attached above a wall or fence can help maintain the character of the streetwall and improve the pedestrian environment along the street.
- 53-5 Parking lots shall be planted with trees to provide a minimum of 50% shading after 15 years in conformance with City Municipal Code Section 17.68, "Landscaping and Paving Regulations." Shading should be calculated by using the expected diameter of the tree at 15 years. A link to the City of Sacramento Parking Lot Tree Shading Design and Maintenance Guidelines is available at:
cityofsacramento.org/parksandrecreation/urbanforest/#right



Landscaping should screen parking lots from the street while still allowing some visibility to promote safety.



This landscaped walkway allows pedestrian access to local businesses.

Commercial



Alternative surfaces such as grass pavers keep stormwater runoff on site and reduce heat production.



Modular pavers are another attractive alternative that helps to keep stormwater runoff on-site.



Bio-swales collect stormwater runoff and improve run-off water quality.

- 53-6 Trees planted in parking lots should be protected with curbs, bollards, or tree grates, or should be located on landscaped walkways.
- 53-7 Use of permeable materials, such as permeable asphalt, grasscrete, and modular pavers, are encouraged to reduce stormwater runoff. Where possible, drainage shall be directed into planting areas to increase percolation of water runoff. Bio-swales are encouraged to collect stormwater runoff and improve run-off water quality.

Sustainability Guidelines

- 53-8 All planting areas, including those designed to accommodate the 2-foot overhang on parking spaces, should be landscaped with groundcover or other planting materials to reduce stormwater runoff.
- 53-9 The use of bio-swales is encouraged to reduce stormwater runoff.
- 53-10 Light colored paving materials should be considered for use as primary paving materials to reduce heat transmission.

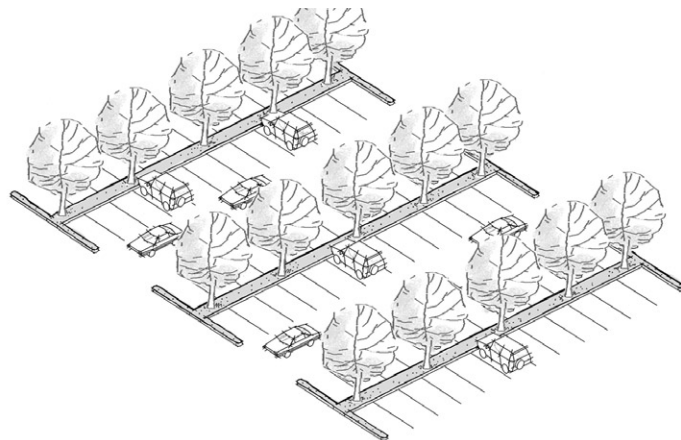

Parking lots shall be designed to provide 50% shading after 15 years.

54 Street Trees

Design Principle

Street trees shall be planted on all streets to provide a visual frame to the street and shade and comfort to visitors to commercial districts.

Rationale

Street trees soften the appearance of the commercial streetscape and make it more comfortable for pedestrians by providing essential shade during the summer months.

General Design Standards and Guidelines

- 54-1 Street trees should be spaced no farther apart than 30 feet on center, and should be located in either a 6-foot wide planting strip between the curb and sidewalk, or within a metal-grated tree planter area of at least 4 feet by 4 feet adjacent to the curb.
- 54-2 Street trees that are not planted and maintained by the City, and that project into the public right-of-way, are subject to a City revocable encroachment permit. Contact the Building Division of the City Development Services Department for more information.
- 54-3 Street trees should be easy to maintain, reduce sidewalk damage, and provide a sufficiently large, wide canopy to shade the sidewalks.
- 54-4 Street trees must be pruned to provide a clear space between the lower branches and the sidewalk and roadway to prevent damage and provide a clear view of building signage, ground floor windows, and doors.
- 54-5 Street trees within the public right-of-way must not be trimmed or removed without consulting the City Department of Parks and Recreation Urban Forest Services at 916-433-6345.
- 54-6 Tree species should be suitable for the Sacramento climate, and should be selected for water conservation. Refer to the following lists for recommended species:

Sacramento Tree Foundation

www.sactree.com/treelInfo/treesWeOffer.html

Sacramento Municipal Utility District (SMUD)

www.smud.org/residential/saving/trees/index.html

City of Sacramento Department of Parks and Recreation

www.cityofsacramento.org/parksandrecreation/urbanforest/index.html



Street trees provide welcome shade for pedestrians.



Landscaped areas add to the beauty of the streetscape.

55 Landscape Elements

Design Principle

Landscape elements shall be used to foster an attractive and comfortable commercial environment.

Rationale

Parks, plazas, and town squares should be developed as the focus of commercial areas, with commercial development opening directly onto these spaces. Parks, plazas, and town squares should include landscape elements, such as ornamental plants and water features, to create visual interest and an attractive, appealing environment.

General Design Standards and Guidelines

- 55-1 Landscaping shall conform to all relevant City regulations and guidelines, including the City Municipal Code Section 124.625, "Landscaping and Paving Regulations."
- 55-2 Plant species should be suitable for the Sacramento climate. Low-water landscaping materials are encouraged.
- 55-3 High-maintenance annuals and perennials should be used only as smaller landscape elements.
- 55-4 The full growth of landscaping materials should be anticipated so that trees and shrubs do not conflict with lighting and roofs.
- 55-5 Landscaped areas are preferred over impermeable paved surfaces.
- 55-6 An automatic irrigation system must be installed to provide consistent coverage of all landscaped areas. Automatic controllers with rain shut-off valves will allow for greater water conservation. Irrigation controls should be screened from view by landscaping or other attractive site materials.
- 55-7 Turf and groundcover are more effectively irrigated with a conventional spray system. Head-to-head spray coverage is recommended. Avoid overspray onto sidewalks and adjacent properties.
- 55-8 A drip irrigation system is recommended for shrubs and trees to provide deeper, more even watering. Drip irrigation permits greater water conservation than a conventional spray system.
- 55-9 Bare soil should be planted or mulched to minimize run-off.

Sustainability Guidelines

- 55-10 Deciduous shade trees and shrubs should be planted, where appropriate, to shade the west and south sides of buildings and all paved areas to reduce heat transmission.
- 55-11 New planting strips located between the sidewalk and street should be a minimum of 6 feet wide to promote the health of shade trees.

56 Hardscape Elements and Street Furniture

Design Principle

Hardscape elements and street furniture shall be selected and installed so as to increase opportunities for people to congregate and interact, and shall complement the surrounding architecture.

Rationale

Hardscape elements and street furniture, such as pedestrian kiosks, benches, transit shelters, newspaper racks, trash cans, and café tables, encourage strolling and window shopping and increase opportunities for casual social interaction. This informal interaction can enhance the appeal and vitality of commercial districts.

General Design Standards and Guidelines

- 56-1 Street furniture should be consistent with the character of existing businesses.
- 56-2 Street furniture should be attractive, functional, easy to maintain, high quality, and vandal resistant.
- 56-3 Street furniture must not block the sidewalk or access to parking.
- 56-4 Seating is highly encouraged. A variety of seating alternatives, such as benches, seat walls, and café tables are possible.
- 56-5 Incorporation of public art into site and building design is encouraged.
- 56-6 The pattern and texture of ground paving materials should fit the context of the district. Use of high-quality brick, stone, textured concrete, terrazzo tile, or other decorative pavers is encouraged.
- 56-7 Hardscape materials that can endure Sacramento's intense weather conditions should be selected.

Broadway Commercial Character Area Design Guidelines

- 56-8 Street furniture on Broadway must complement the traditional architecture found in the area. Ornate, cast-metal benches could be used.

Stockton Commercial Character Area Design Guidelines

- 56-9 Simple contemporary wood or metal designs fit the context of the area.

Sustainability Guidelines

- 56-10 Pervious concrete should be used, when feasible, because it has better reflectivity, reducing heat transmission and stormwater runoff.
- 56-11 The use of recycled paving materials is encouraged.



Traditional bench designs should be used in the Broadway Commercial Character Area.



Trash receptacles should be provided at regular intervals



More contemporary bench designs are desirable for the Stockton Commercial Character Area.

This Page Intentionally Left Blank

Appendices

Appendix A — Additional Resources	106
General Planning Resources	106
Commercial and Home Improvement Funding	106
Historic Preservation Standards	107
Manufactured Homes	107
Appendix B — Predominant Residential Architectural Styles	108
Ranch	109
Minimal Traditional	110
Queen Anne	111
Bungalow and Sacramento Highwater Bungalow	112
Craftsman Bungalow	113
Oak Park Vernacular	114
Appendix C — Commercial Architectural Styles	115
Classical Style	116
Neoclassical Style	117
California Mission Revival	118
Streamline Moderne	119
Appendix D — U.S. Secretary of the Interior’s Standards for Rehabilitation of Historic Buildings	120
Appendix E — Sustainability Through High Performance Building Design	121
Appendix F — Glossary of Terms	123

APPENDIX A — ADDITIONAL RESOURCES

These resources provide more information about the neighborhoods, as well as relevant City programs and ordinances.

General Planning Resources

Sacramento Municipal Code

Title 17 of the Sacramento Municipal Code contains information relevant to development standards, including height limits and setbacks. The code is available at:

<http://cityofsacramento.org/dsd/citycode.htm> (Go to the zoning code section.)

Implementation Plan

The 2005-2009 Oak Park Implementation Plan acts as the operating plan for the Sacramento Housing and Redevelopment Agency (SHRA) with regard to the Oak Park neighborhood. The document outlines goals, specific projects, and proposed costs for implementation. The plan is available at:

www.shra.org/Content/CommunityDevelopment/ImplPlanTOC.htm

Oak Park Renaissance Community Master Plan

Approved in 2003, the *Oak Park Renaissance Community Master Plan* covers the area bounded by Broadway on the north, Martin Luther King, Jr. Boulevard on the west, Eighth Avenue on the south, and Stockton Boulevard on the east. The area is primarily residential except for sections along Broadway, Stockton Boulevard, and Martin Luther King Jr. Boulevard. The document provides revitalization strategies for the neighborhood, including streetscape and infrastructure improvements, and residential infill development. Limited residential design guidelines are included.

www.shra.org/Content/CommunityDevelopment/OakPark/OPProjects/OPRen/MasterPlan.pdf

Commercial and Home Improvement Funding

Commercial Revitalization Program

This SHRA program offers free architectural and construction management services for business owners interested in improving the appearance and function of older commercial buildings. Property owners must invest a minimum of \$10,000 in improvements to be eligible. Funding for improvements is provided as a matching rebate of up to \$50,000. For more information, contact SHRA at (916) 440-1328.

Grow Sacramento Fund

The Grow Sacramento Fund (GSF) is a non-profit lender providing small business loans under the U.S. Small Business Administration's 7(a) program. GSF offers technical assistance and provides loans between \$25,000 and \$2,000,000 at market-rate financing for new and expanding businesses in the City and County of Sacramento. Loans may be used to acquire land and buildings, make leasehold improvements, and purchase machinery and equipment. For more information, contact SHRA at (916) 440-1399 ext. 1414.

Home Repair and Improvement Programs

SHRA administers several home repair and improvement programs, including emergency repair, accessibility, and repair assistance for seniors. Homeowner rehabilitation loans are also available. To learn more about these programs, see the SHRA website or contact SHRA at (916) 440-1322.

www.shra.org/Content/Housing/HomeRepair/HomeRepairTOC.htm

Historic Preservation Standards

U.S. Secretary of the Interior's Standards for Rehabilitation

The U.S. Secretary of the Interior sets the standard for the rehabilitation and maintenance of historic structures. While these Design Standards and Guidelines are not intended to set standards for historic structures, some of the information on this National Park Service website may be useful to individuals who want to learn more about how to protect residential properties that are 50 years old or older.

www.cr.nps.gov/tps/standguide/rehab/rehab_index.htm

City of Sacramento Historic Preservation

The City's Historic Preservation Department oversees the environmental review of potentially historic structures 50 years old or older. Structures proposed for demolition may also be subject to review as potentially eligible for listing on the City's register of historic landmarks and contributing resources. The City has adopted the Secretary of the Interior's Standards for review of historic preservation projects under Sacramento Municipal Code, Chapter 15.124, which can be found at:

www.qcode.us/codes/sacramento/view.php?topic=15-15_124

Work done in compliance with the U.S. Secretary of the Interior's Standards is considered to have a less than significant impact for purposes of environmental review under the California Environmental Quality Act (CEQA).

Manufactured Homes

U.S. Department of Housing and Urban Development

www.hud.gov/offices/hsg/sfh/mhs/mhshome.cfm

Manufactured Housing Institute

The 2000 Manufactured Housing Improvement Act

www.manufacturedhousing.org/lib/showtemp_detail01.asp?id=106&cat=6

California Health and Safety Code

Mobilehomes-Manufactured Housing Act of 1980 (Division 13, Part 2, California Health and Safety Code)

www.leginfo.ca.gov/html/hsc_table_of_contents.html

California Manufactured Housing Institute

www.cmhi.org

APPENDIX B — PREDOMINANT RESIDENTIAL ARCHITECTURAL STYLES

The most typical existing residential architectural styles in Oak Park are detailed in this section. The architectural styles shown are graphically represented by photos taken within the redevelopment area. The examples are not *intended to be emulated in new construction in their pure form*, but are provided for informational purposes to help applicants better understand and respond to the existing residential context.

Ranch

The Ranch style home was popular from the 1950s through the 1970s. Low and rambling, the Ranch home occupied more square footage than previous architectural styles. Ranch style homes can have a simple rectangular floor plan, or an L-, T-, or U-shape, with the attached garage usually as one arm of these more complex layouts. This style is typically found south of 14th Avenue in Oak Park.

Ranch design features:

- wide, horizontal facade
- built-in garage common
- single story
- low-pitched hipped, cross-gabled, and side-gabled roofs
- moderate to wide eave overhang
- wood or brick wall cladding (sometimes in combination)
- ribbon windows
- picture windows
- minimal front entry features

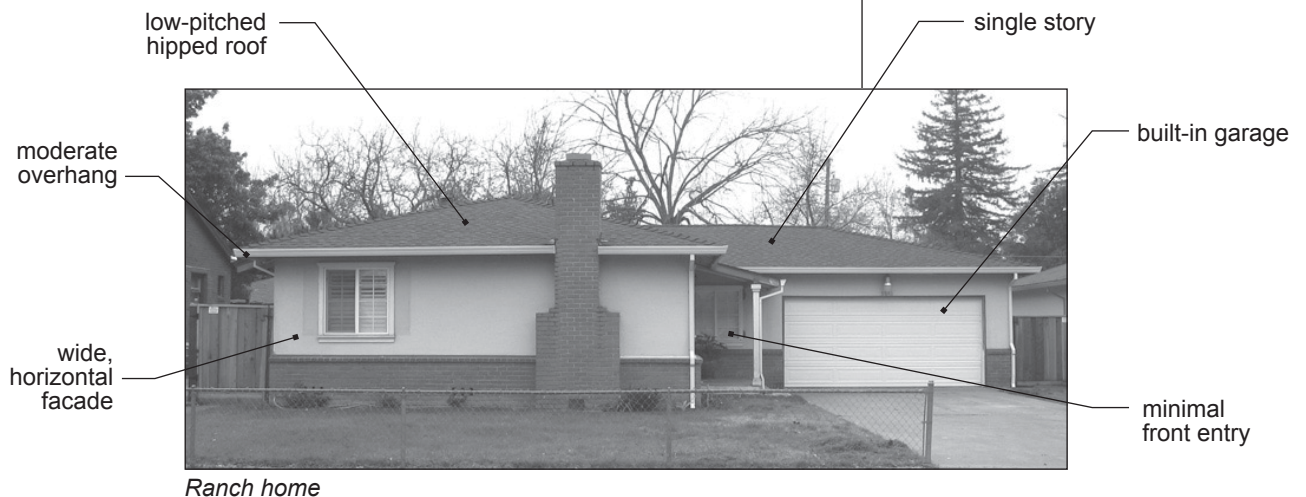

Appendix B

Minimal Traditional

Minimal Traditional was a popular style from the 1930s into the 1950s. The homes were inexpensive to build and allowed a greater proportion of the general populace to enjoy home ownership. Their styling reflects the influence of Tudor, Colonial Revival, and Craftsman Cottages that were popular through the 1920s. However, Minimal Traditional homes are considerably more streamlined and display simpler decorative features than their predecessors. This style is typically found south of 14th Avenue.

Minimal Traditional design features:

- low-pitched roof
- usually one story
- minimal decoration
- side gable roof, sometimes with front crossing gable
- minimal overhang of eaves
- wood or brick cladding
- entry porches



Minimal Traditional home

Queen Anne

Typically of wood frame construction with irregular plans, Queen Anne dwellings were popular in the late 19th and early 20th centuries. Numerous Queen Anne homes can be found in Oak Park, particularly in the Residential Special Character Area.

Queen Anne design features:

- asymmetrical facades
- conical or pyramidal roof shapes
- extensive ornamentation
- wrap-around porch
- bays, turrets, dormers, and chimneys common
- vertical massing



Queen Anne home

Appendix B



This home has the low-slung horizontal form of many bungalows.



This bungalow has the front crossing gable and triangular knee braces under the eaves typical of the style.

Bungalow and Sacramento Highwater Bungalow

The Bungalow style was popular during the first 30 years of the 20th century. In fact, most of the smaller homes constructed in the United States during this period were built in the bungalow style, which included many variations, including period revival styling. The Sacramento Highwater Bungalow follows the basic bungalow style, with the addition of high foundations to minimize damage from flooding. Both Bungalow and Sacramento Highwater Bungalow homes are found throughout Oak Park.

Bungalow design features:

- one or one-and-a-half stories
- low-pitched roof, often with projecting rafter tails and side gables
- front porch (either partial width or full width)
- stucco, cast plaster, clinker brick, or clapboard exterior walls
- casement, sash, and bay windows, often with awnings and shutters
- tapered square columns on porches

Sacramento Highwater Bungalow design features:

- foundation raised one-half story to minimize impacts of flooding



Sacramento Highwater Bungalow with raised main story

Craftsman Bungalow

A common architectural style in the early 20th century, Craftsman and Craftsman Bungalow homes are distinguished by good workmanship and natural materials, such as wood and stone. There are many homes in the Oak Park area that draw inspiration from the Craftsman style, without having the more elaborate detailing typical of the form, particularly north of 12th Avenue.

Craftsman design features:

- one or one-and-a-half stories
- prominent, low-pitched gable or hip roof
- wide eaves with exposed roof rafters
- double-hung windows with small panes in upper portion
- dormer windows or roof vents
- decorative braces
- porch with tapered square columns

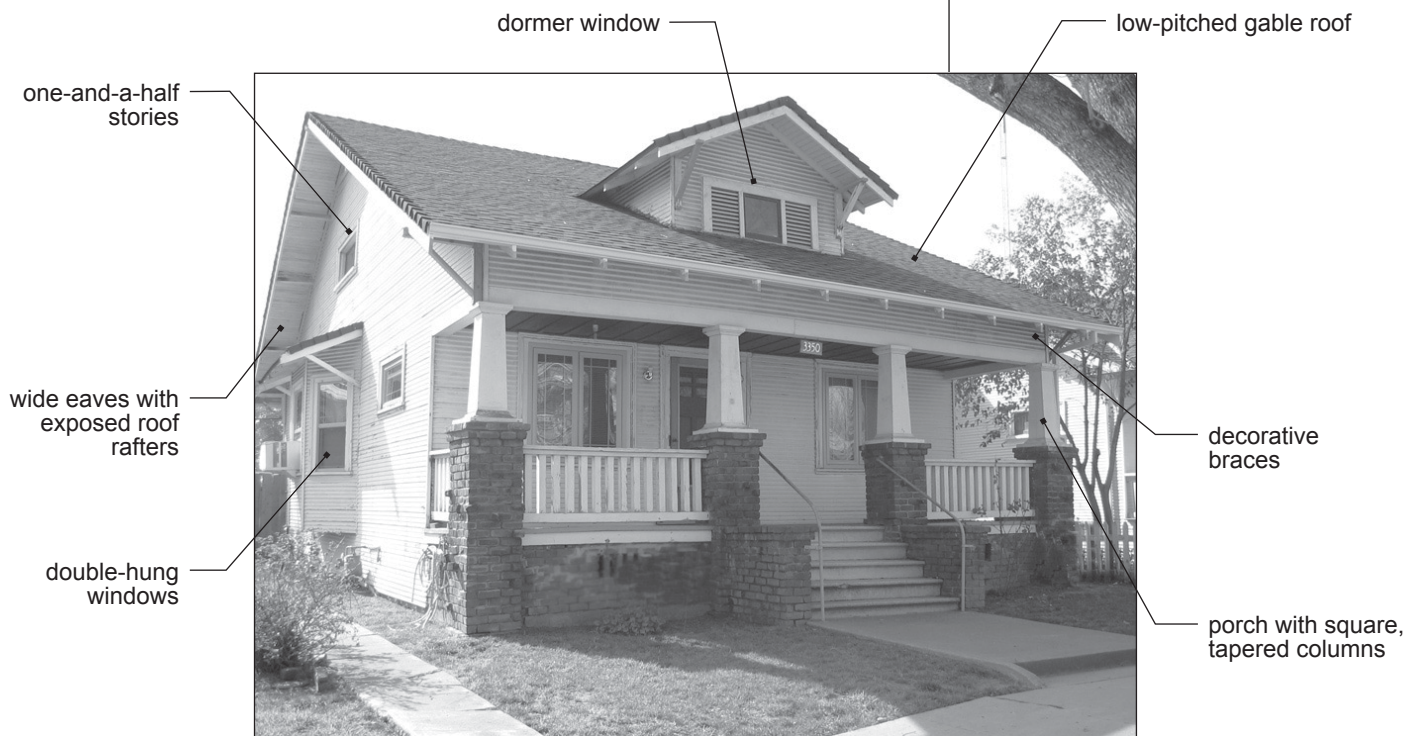

Bungalow with Craftsman influences

Appendix B

Oak Park Vernacular

Some homes represent local vernacular forms. Vernacular architecture refers to a type of regional construction that employs common forms and materials, often developed in response to the local climate and building traditions. Vernacular residences drew inspiration from the popular architectural styles of the day, constructed in simplified forms to meet the tastes and budgets of their owners.

Although not representing a specific architectural style, the Oak Park Vernacular form is common in Oak Park, and is exemplified by the following characteristics:

Oak Park Vernacular design features:

- small size (one to two bedrooms)
- ornamentation primarily through structural elements
- windows small in number and area, and usually double- or single-hung sash
- small porch or stoop
- simple roof lines
- horizontal wood lap siding common, with stucco less common

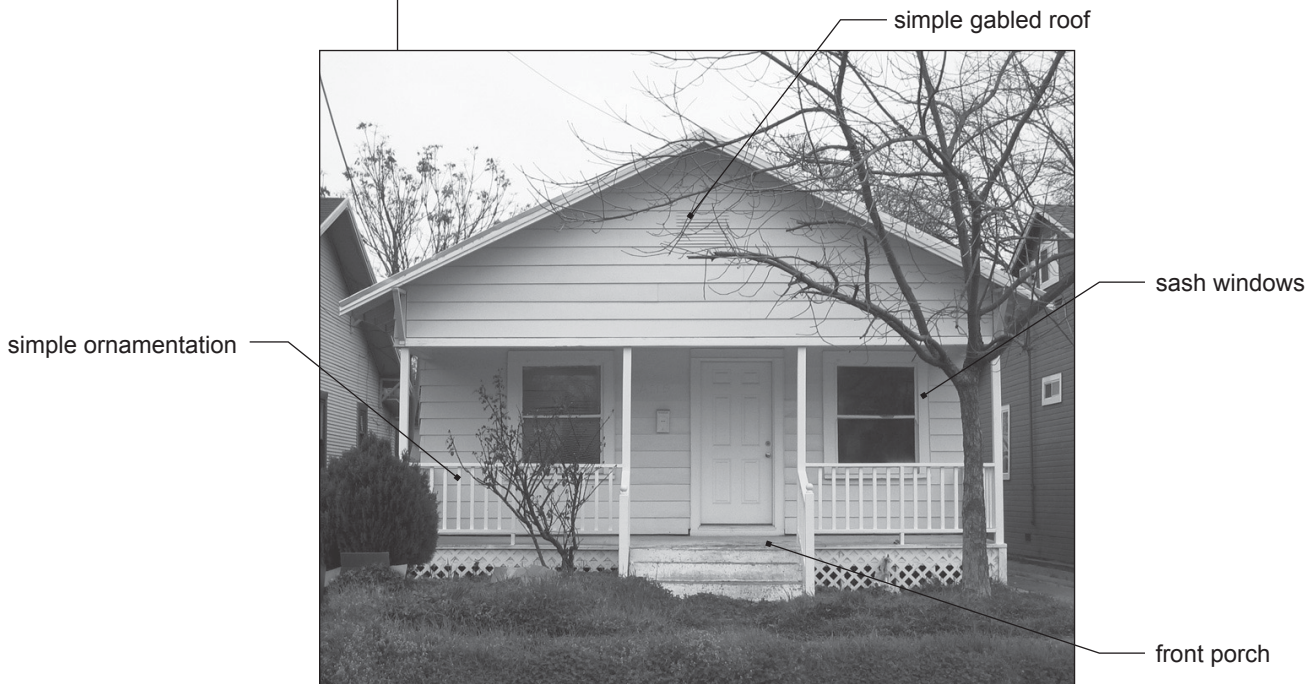

Oak Park Vernacular

APPENDIX C — COMMERCIAL ARCHITECTURAL STYLES

Older commercial structures in Oak Park represent a variety of styles, including Classical, Neoclassical, California Mission Revival, and Streamline Moderne, which are described in this section. The architectural styles shown are presented for informational purposes only to provide developers and designers with information on the neighborhood context that should be considered for commercial infill and renovations. They are not necessarily intended as models to be duplicated in new construction.

Appendix C

Classical Style

The Classical style uses simple, formal elements. Wall areas of minimal decoration are often offset with highly-decorated areas. This style can be found in Oak Park, with the Citizens Bank of Oak Park on 35th Street as a significant example.

Classical design features:

- emphasis on simple massing;
- symmetrical facades;
- simple geometric form;
- detailed, repetitive eave, window, and banding elements; and
- ornamented parapets, sometimes used with balustrades.



detailed ornamentation on eaves, doors, and windows

symmetrical facade with horizontal banding

simple massing

Classical Style with Prairie School Influences: Citizens Bank of Oak Park building on 35th Street

Neoclassical Style

This imposing style of building was mostly used in buildings of importance, such as museums, government buildings, educational institutions, and banks. This style is represented by the U.S. Bank Building on Broadway.

Neoclassical design features:

- classical symmetry;
- full-height porch with temple-like front;
- prominent columns with decorative caps;
- square blocks (modillions) lining the underside of the roof soffits and used for decoration;
- classical ornamentation; and
- masonry construction, and often terra cotta clad.



full-height,
temple-like porch

modillions on
underside of soffits

classical ornamentation

prominent columns with
decorative caps

Neoclassical U.S. Bank building on Broadway

Appendix C

California Mission Revival

The California Mission Revival style originated in southern California and was considered the “California counterpart” to the Colonial Revival style popular in the northeastern United States in the early 20th century. Rather than imitating design influences imported from the East Coast, this style was derived from historic Southwestern influences, including Puebloan and Spanish mission architecture. Many smaller commercial structures on Broadway and Stockton Boulevard display California Mission Revival influences.

California Mission Revival design features:

- dormers and roof parapets based on the arching and fluted shapes of Spanish missions;
- wide, overhanging eaves;
- exposed rafters;
- red-tiled roof;
- stucco walls; and
- arched windows and doors on ground level.

fluted roof parapet



red tile roofing

stucco walls

California Mission Revival: Primo's Restaurant incorporates both California Mission Revival elements and glass block (on the ground floor) common in Streamline Moderne structures (described on the following page).

Streamline Moderne

The Streamline Moderne style, also known as Art Moderne, became popular in the 1930s and 1940s. Streamline Moderne design was represented by low, horizontal structures with smooth, streamlined surfaces that were often punctuated by contrasting vertical elements, such as blade signs. Structural glass, porcelain enamel panels, and tiles were used to produce polychrome designs for the exterior covering of the buildings. Glass blocks were also commonly used in this style, as were large glass show windows. This style is mostly commonly seen in movie theaters, department stores, gas stations, and bus stations. A few examples of this style can be found in Oak Park along Broadway and Stockton Boulevard.

Streamline Moderne design features:

- smooth, rounded wall surfaces, often of stucco;
- flat roof with small ledge at roofline;
- horizontal grooves or lines in walls, sometimes of fluted or pressed metal;
- often asymmetrical facade;
- casement or corner windows or other horizontally arranged windows;
- glass-block windows, often curved; and
- an emphasis on the horizontal, with vertical elements.

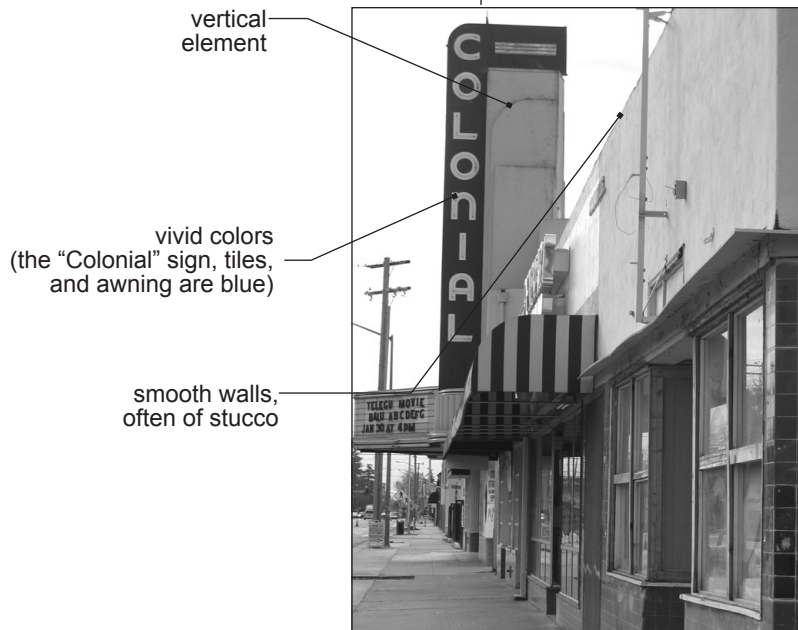

Streamline Moderne: Colonial Theater in Oak Park

APPENDIX D — U.S. SECRETARY OF THE INTERIOR’S STANDARDS FOR REHABILITATION OF HISTORIC BUILDINGS

For properties deemed historic or for eligible historic resources, the Secretary of Interior’s Rehabilitation Standards are used to review the proposed work. The rehabilitation standards are:

1. A property will be used as it was historically or be given a new use that requires minimal change to its distinctive features, spaces, and spatial relationships.
2. The historic character of a property will be retained and preserved. The removal of distinctive materials or alteration of features, spaces and spatial relationships that characterize a property will be avoided.
3. Each property will be recognized as a physical record of its time, place, and use. Changes that create a false sense of historical development, such as adding conjectural features or elements from other historic properties, will not be undertaken.
4. Changes to a property that have acquired historic significance in their own right will be retained and preserved.
5. Distinctive materials, features, finishes, and construction techniques or examples of craftsmanship that characterize a property will be preserved.
6. Deteriorated historic features will be repaired rather than replaced. Where the severity of deterioration requires replacement of a distinctive feature, the new feature will match the old in design, color, texture, and, where possible, materials. Replacement of missing features will be substantiated by documentary and physical evidence.
7. Chemical or physical treatments, if appropriate, will be undertaken using the gentlest means possible. Treatments that cause damage to historic materials will not be used.
8. Archaeological resources will be protected and preserved in place. If such resources must be disrupted, mitigation measures will be undertaken.
9. New additions, exterior alterations, or related new construction will not destroy historic materials, features, and spatial relationships that characterize the property. The new work shall be differentiated from the old and will be compatible with the historic materials, features, size, scale and proportion, and massing to protect the integrity of the property and its environment.
10. New additions and adjacent or related new construction will be undertaken in such a manner that, if removed in the future, the essential form and integrity of the historic property and its environment would be unimpaired.

APPENDIX E — SUSTAINABILITY THROUGH HIGH PERFORMANCE BUILDING DESIGN

The City encourages builders and owners to construct structures that are designed, built, renovated, operated or reused in an ecological and resource-efficient manner. Buildings should be designed to meet certain objectives such as protecting occupant health; using energy, water, and other resources more efficiently; and reducing the overall impact to the environment. These design features are not only the responsible thing to do for the environment and our community but they will also help lower expenses and create a more comfortable living space.

While the City has included a number of sustainability design guidelines in this document, this appendix includes more resources to assist in building cost-effective, ecological and resource-efficient buildings.

Whole Building

Build It Green, New Home Construction Green Building Guidelines, December 2005

www.builditgreen.org/newconstructionguidelines.pdf

Celery Design Collaborative, *San Mateo Countywide Guidelines: Sustainable Buildings*, February 2004.

www.recycleworks.org/greenbuilding/gbg_intro.html

U.S. Green Building Council's Leadership in Energy and Environmental Design (LEED) Program

The LEED program is intended to promote "green" design and construction practices that can result in more environmentally sensitive site design, water quality and management practices, energy conservation, and the use of sustainable materials. For more information, go to:

www.usgbc.org/DisplayPage.aspx?CategoryID=19

Energy

Sacramento Municipal Utility District (SMUD)

SMUD offers a variety of resources, including a reference room, educational workshops and seminars, and a program that promotes the use and evaluation of innovative technologies by consumers.

Overview of SMUD Programs

www.smud.org/education/

Promotions, Rebates, and Financing Website

www.smud.org/residential/saving/rebate.html

Residential Solar Website

www.smud.org/green/solar/index.html

Appendix E

Lighting

California Lighting Technology Center, Residential Lighting Design Guide,
Best Practice and Lighting Design to Help Builders Comply with California's 2005 Title 24 Energy Code

<http://cltc.ucdavis.edu/title-24-residential-lighting-design-guide>

Energy Design Resources, Day-lighting Design Brief

<http://www.energydesignresources.com/resource/19/>

Water

California Urban Water Conservation Council, H2ouse: Water Saver Home Website

www.h2ouse.org

Landscaping

Sacramento Tree Foundation, Publications and Guidelines Website,

www.sactree.com/aboutUs/publications.html

Materials

California Integrated Waste Management Board, Construction and Demolition (C&D) Debris Recycling Specifications

www.ciwmb.ca.gov/ConDemo/Specs/

Green Project Specifications

www.ciwmb.ca.gov/greenbuilding/Specs/

Green Product Directories

www.ciwmb.ca.gov/greenbuilding/ToolKit.htm#Product

APPENDIX F — GLOSSARY OF TERMS

Arcade: a roofed passageway with shops on one or both sides.

Balustrade: a railing with supporting columns known as balusters.

Capital: the uppermost section of a column or pillar, which is often decorated.

Cladding: the protective exterior surface of a building, such as wood, metal, brick, or stucco.

Cornice: a crowning, overhanging projection from the roof, usually the uppermost segment of the entablature in classical architecture.

Cupola: a small dome on a roof, or a circular or polygonal turret.

Dormer: a structure projecting from a sloping roof that usually includes a small gable with one or more windows.

Entablature: the three layers above a column in classical architecture, consisting of the architrave, frieze, and cornice.

Facade: the exterior surface of a building.

Gable: the triangular end of a wall above the eaves that abuts the roofline above it.

Infill: new construction on vacant or redeveloped lots within an established neighborhood.

Manufactured Home: a factory-built home that is shipped to and installed at the site.

Massing: the arrangement of the physical volume of a building.

Mullion Window: a window with vertical and horizontal strips that divide the window into separate panes.

Parapet: a low wall along the edge of a roof.

Pitch (of a roof): recorded as a ratio of vertical to horizontal measures. A 5:12 roof, for instance, means 5 inches of vertical rise for every 12 inches of horizontal run.

Plinth: the solid base of a column or pillar, which is often square, round, or rectangular.

Portico: a range of columns or arches connected to or merged with the facade of a building that forms a walkway or porch.

Ribbon Window: A horizontal series of narrow windows across the facade of a building.

Running Gear: the tires, wheels, axles, and springs that allow a manufactured home to be moved from place to place without dismantling it.

Setback: (1) The prescribed distance between the lot line and the edge of the building's footprint. (2) The horizontal distance between the exterior wall of one floor and the next story exterior wall.

Sidelight: an area of framed glass along the sides of a door.

Site-built: constructed at the site of the building without use of prefabricated sections.

Streetwall: the line or "wall" formed by the front facades of buildings on a block or street.

Transom: an area of framed glass at the top of a door or window.