

Del Paso Heights Residential and Commercial Design Guidelines



Del Paso Heights Redevelopment Area and
Design Review District



EDAW

JANUARY 2007

Table of Contents

- Introduction** 1
 - Purpose of the Design Guidelines** 1
 - The City’s Commitment to Sustainability** 2
 - How to Use the Design Guidelines** 2
 - Design Review Process** 3
 - Location of the Del Paso Heights
Redevelopment Area and Design Review District** 4
- Residential Design Guidelines** 5
 - Residential History and Neighborhood Context** 6
- SINGLE-FAMILY RESIDENTIAL** 7
 - Site Design** 8
 - 1 Setbacks and Orientation 9
 - 2 Scale and Mass 11
 - 3 Number of Stories. 12
 - 4 Garages. 13
 - 5 Parking and Driveway Location. 14
 - Architectural Elements** 15
 - 6 Architectural Character and Detailing. 16
 - 7 Roof Styles 17
 - 8 Entry Features 18
 - 9 Doors 19
 - 10 Windows 20
 - 11 Siding 21
 - 12 Roofing 22
 - 13 Lighting and Addresses 24

Table of Contents

Site Elements	25
14 Landscaping	26
15 Irrigation.	28
16 Fencing	29
17 Paving/Hardscape Surfaces	30
18 Utilities and Storage Facilities	31
19 Access Ramps	32
MULTI-FAMILY RESIDENTIAL	33
Site Design	34
20 Relationship to the Street.	35
21 Setbacks	36
22 Interior Common Spaces	37
23 Scale and Mass	38
24 Parking Lots.	39
Architectural Elements	40
25 Garages.	41
26 Entry Features	42
27 Lighting	43
28 Signage and Addresses.	44
Site Elements	45
29 Landscaping	46
30 Irrigation.	48
31 Fencing	49
32 Paving/Hardscape Surfaces	50
33 Services and Utilities	51
MANUFACTURED HOMES	53
Site Design	55
34 Setbacks, Garages, and Parking	55
Architectural Elements	56
35 Creating an Attractive Streetside Facade.	56
36 Applying Site-Built Home Standards to Roof Design	57
37 Giving an Appearance of Permanency	58
38 Selecting Suitable Materials	59

Table of Contents

Commercial Design Guidelines	61
Commercial History and Neighborhood Context	62
Site Design	63
39 Building Orientation, Setbacks, and Build-To Lines	64
40 Parking	65
Architectural Elements	66
41 Building Height, Massing, and Scale	67
42 Building Facades	68
43 Additions	72
44 Roof Forms	73
45 Entry Features	74
46 Windows and Doors	75
47 Color	76
48 Materials	77
49 Canopies, Awnings, and Arcades	78
50 Signage and Graphics	80
51 Lighting	82
52 Service Areas and Utilities	84
Streetscape Guidelines	86
53 Parking Lot Design	87
54 Street Trees	89
55 Landscape Elements	90
56 Hardscape Elements and Street Furniture	91
Appendices	93
Appendix A — Additional Resources	94
Appendix B — Predominant Residential Architectural Styles	97
Appendix C — Predominant Commercial Architectural Style	100
Appendix D — Sustainability Through High Performance Building Design	102
Appendix E — Glossary of Terms	104

Table of Contents

This Page Intentionally Left Blank

Introduction

PURPOSE OF THE DESIGN GUIDELINES

The Del Paso Heights Residential and Commercial Design Guidelines (Design Guidelines) have been developed for the Del Paso Heights Redevelopment Area and Design Review District. They provide consistent design principles for residential and commercial structures to contribute to the creation of a neighborhood with a positive, cohesive sense of place, and can improve the overall character of the neighborhood by making it a more attractive, safe, and inviting place to live.

The Design Guidelines have been created for use by residents, developers, design professionals, City of Sacramento (City) planning staff, and the City's design review boards. They are intended to facilitate the design review process by helping applicants and staff identify and devise solutions for design issues early in the application process. In summary, these Design Guidelines are intended to:

- create a sense of place and enhance community identity;
- promote neighborhood pride;
- encourage high-quality development and creative design options;
- provide clear and usable design direction to project applicants, developers, designers, and City planning staff;
- protect and enhance property values and community economic viability; and
- facilitate a clear and expeditious project review process.

Projects will be reviewed for compliance with the design principles identified in this document. Although it is understood that not all design principles will be applicable to all proposed projects, conformance with relevant principles is required.

Overall, the Design Guidelines are intended to encourage consistent design while allowing for variety and innovation. City staff do not advocate a particular architectural style or styles, and will review all applications on the basis of this document.

THE CITY'S COMMITMENT TO SUSTAINABILITY

In 2006, the Sacramento City Council adopted a vision for the city reflecting the Council's commitment to "sustainability and livability." Based on the Council's vision, the City continues to develop and refine standards and guidelines intended to influence the design of future development in Sacramento.

In the meantime, these Design Guidelines include a number of specific guidelines that address environmentally responsive site, building, and landscaping design. In addition, Appendix D provides additional resources and information.

HOW TO USE THE DESIGN GUIDELINES

Each subsection within the Design Guidelines is organized to include the following elements:

Design Principle

The *design principle* is a general concept that must be met by all projects, and is further delineated by the individual design guidelines.

Rationale

The *rationale* explains the key features of the design principle and how it relates to the neighborhood context.

Design Guidelines

The *design guidelines* provide a list of specific recommendations to ensure that appropriate Design Principles are applied to project design.

Sustainability Design Guidelines

The *sustainability design guidelines* provide suggestions for high performance building and landscape design.

Graphics

Each section within the Design Guidelines is supplemented by drawings and photos that are intended to provide visual support for the principles and guidelines.

DESIGN REVIEW PROCESS

City planning staff must review the design of any proposed infill project or major renovation of or addition to an existing structure within the Del Paso Heights Redevelopment Area and Design Review District. City staff will then provide early notification to adjacent property owners and community groups of the proposed project. Applicants should expect to communicate with planning staff at several key junctures in the application process, including a pre-application meeting and a meeting following the review process to discuss any revisions. Once a project has been approved by City planning staff or the appropriate review board, as necessary, an application for a building permit may be submitted if other planning entitlements needed for the project have been approved.

Introduction

LOCATION OF THE DEL PASO HEIGHTS REDEVELOPMENT AREA AND DESIGN REVIEW DISTRICT

The Del Paso Heights Redevelopment Area and Design Review District is located within the City of Sacramento, south of Interstate 80, as shown on the maps below.

Residents and business owners who wish to determine whether their property is within the Del Paso Heights Design Review District may call the help line at (916) 808-5656 or view maps at the City's website:

<http://www.cityofsacramento.org/dsd/maps/DesignReviewMaps.cfm>

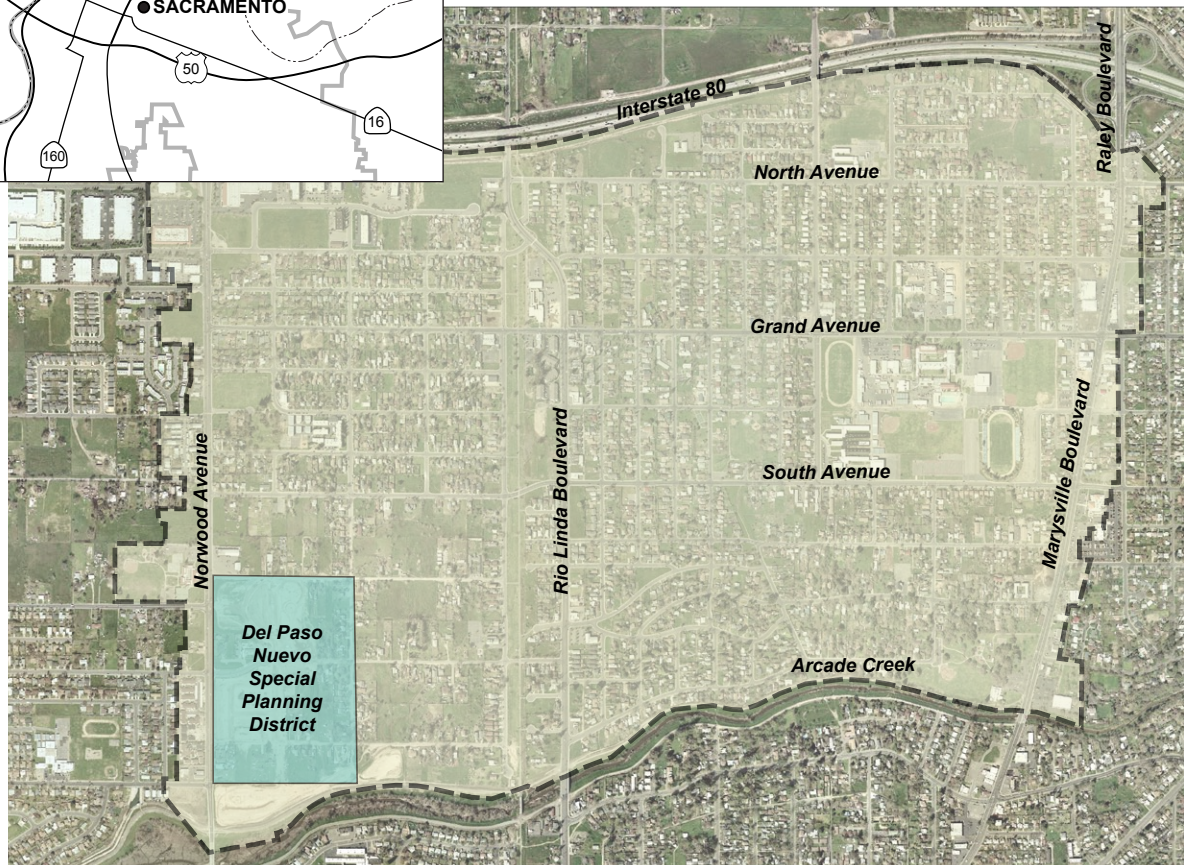

Residential Design Guidelines

The Residential Design Guidelines are intended to be applied to all residential infill construction, as well as additions or renovations to existing dwellings. Separate sections in this document address the design of single-family and multi-family dwellings and manufactured homes.

Del Paso Heights is a long-established neighborhood with an ongoing pattern of infill construction resulting in a diverse and interesting residential neighborhood fabric. However, this variety of residential structures poses unique challenges for Del Paso Heights applicants who wish to construct new infill homes or make renovations or additions to existing structures.

One recent trend in infill construction is market demand for moderately priced new homes in close proximity to the city center. These infill homes are often significantly larger than older existing homes. In addition, new construction methods and current architectural styles often differ from those of older, established homes, sometimes resulting in homes that are noticeably different in appearance from established homes.

Despite these challenges, it is essential that applicants balance contemporary construction methods and architectural styles with respect for the neighborhood's established scale, form, and patterns of existing development. Finding that balance lies in the continued creation of neighborhoods that are visually cohesive, yet variable and adaptable. These Design Guidelines are intended to provide principles and guidelines that support the established residential context while providing room for new infill that can enliven and revitalize neighborhoods.

Introduction

RESIDENTIAL HISTORY AND NEIGHBORHOOD CONTEXT

Del Paso Heights was originally part of the Rancho Del Paso horse farm, which was sold at the turn of the twentieth century to the Sacramento Valley Colonization Company and subsequently subdivided. Residential development in Del Paso Heights experienced a northward progression of development, with lots becoming smaller as development moved north.

The area south of Nogales Street and east of Alvarado Boulevard represents Del Paso Heights' primary residential growth before World War II (WWII). Lots in this area were established in the 1930s and 1930s, and are long and narrow, averaging 52 feet by 235 feet. Homes in this area range from 900 to 1,200 square feet.

During WWII, the neighborhood's proximity to McClellan Air Force Base led to its rapid growth as a source of employee housing in the area north and west of Grant Union High School. WWII era construction can be found between South and North Avenues and includes lots that average 52 feet by 120 feet, with homes ranging from 700 to 900 square feet.

The WWII boom was short-lived, however, and after the war, growth slowed and the neighborhood lacked a significant source of employment. When suburbanization increased in the 1950s and 1960s, the area north of North Avenue saw significant growth. Homes were built on 38-foot by 100-foot lots, and ranged from 1,200–1,800 square feet.

Del Paso Nuevo Special Planning District (Del Paso Nuevo SPD) is an example of the most recent single-family development in Del Paso Heights. It is located adjacent to Norwood Avenue, between South Avenue and Arcade Creek. The Del Paso Nuevo SPD is subject to its own set of guidelines that address residential and commercial design and development within its boundaries. The residential development in this new community has been influenced by New Urbanist design principles, which promote the creation and restoration of diverse, walkable, compact, and vibrant mixed-use neighborhoods. Anyone carrying out development in this area is advised to contact the Sacramento Housing and Redevelopment Agency, Housing Policy and Development Department at (916) 440-1328 for more information.



Typical Del Paso Heights home



Typical Del Paso Heights home

Residential Design Guidelines



Single-family Residential

There are many ways to design a good home. The City Development Services Department has pre-approved plans that can reduce application time and aid the new home builder, and these plans do not exhaust the many possible design options.

The home shown below displays some of the key characteristics that are recommended in the Design Guidelines, and how these design features might be applied to residential infill, additions, and renovations. This sample home is intended as an example only, since the Design Guidelines are sufficiently flexible to allow for many variations in home styles and design.

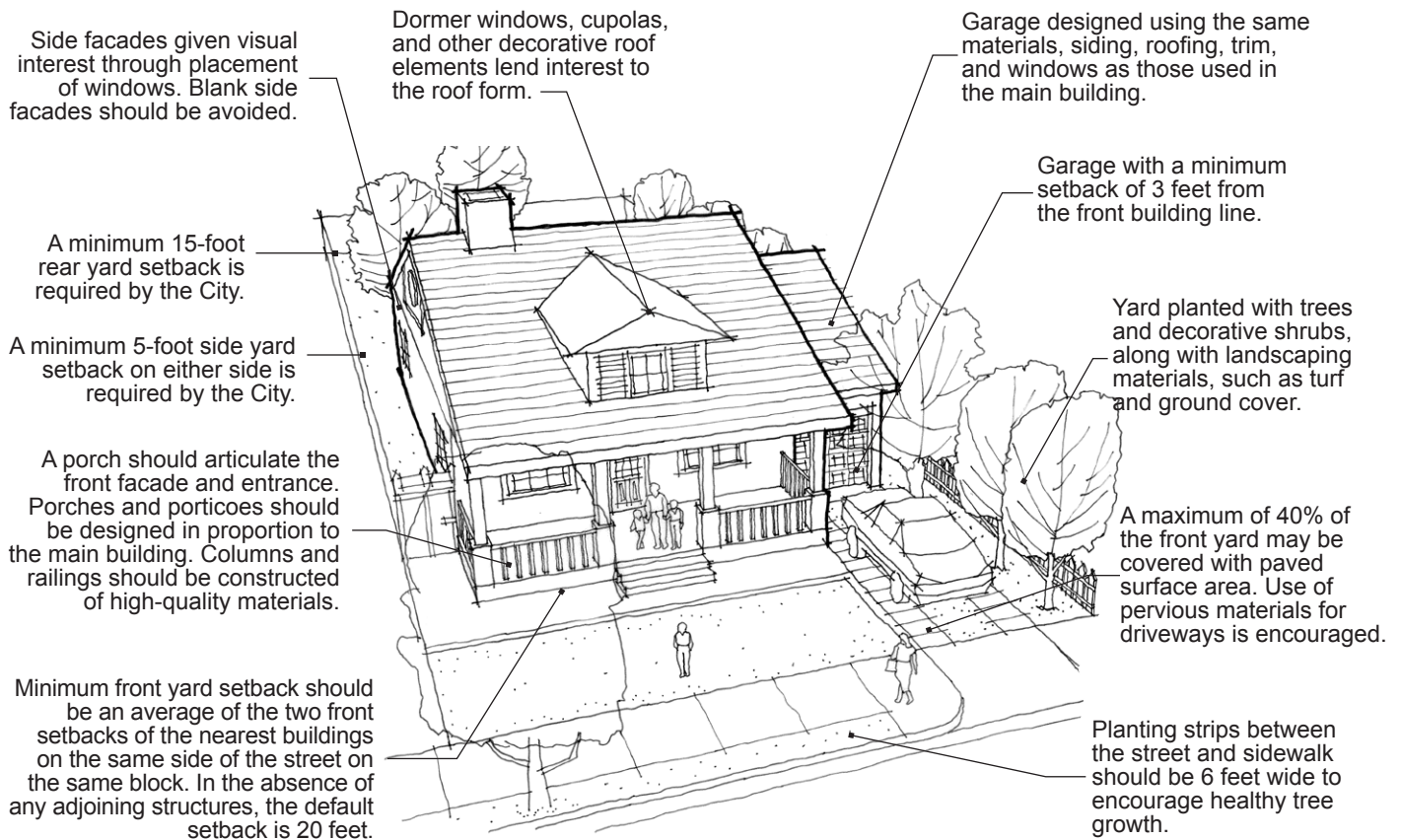

Single-family Residential Home with Required and Recommended Design Features

SITE DESIGN

Site design addresses a home's location on the lot, its orientation toward the street and adjacent buildings, and its overall layout relative to the site. The site design of infill homes and additions to existing homes should emphasize respect for the context of established structures. In addition, infill homes and some additions, where appropriate, should:

- reflect the scale of existing homes on the block;
- in most cases, be located toward the front of the lot;
- provide an entry facing the street to create a welcoming appearance and to give homes "curb appeal";
- minimize the appearance of the garage by locating it recessed to the main structure at the side or rear of the home; and
- minimize the appearance of mass in two-story homes with an articulated facade.

Single-family Residential

1 Setbacks and Orientation

Design Principle

The front setback and the placement of the home on the lot should correspond to the prevailing setbacks of other homes on the block to create a consistent appearance along the street.

Rationale

Well-designed homes enhance their street by respecting the existing context while not succumbing to uniformity. Front yard setbacks may be slightly varied to create interest, but should contribute to the established assemblage of homes on the block. Setbacks in Del Paso Heights are larger south of South Avenue, and become progressively smaller as one moves north.

Design Guidelines

- 1-1 Homes should be oriented toward the front of the lot to encourage an active visual relationship with the street.
- 1-2 Homes should face the street, with the front entry toward the street side.
- 1-3 Infill structures should reinforce the existing rhythm of building widths and side setbacks.
- 1-4 The front setback of the home should be an average of the setbacks of existing homes on the block.

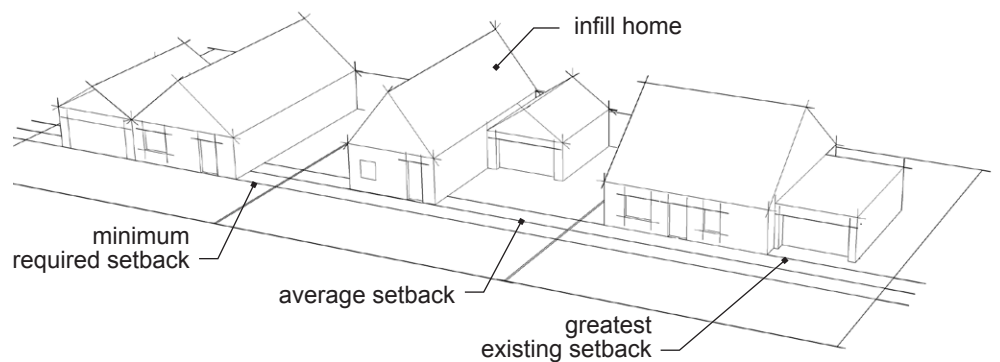

Build to the average front setback

Single-family Residential



Relatively smaller front yard setbacks are typical of many homes north of North Avenue.



Relatively larger front yard setbacks are typical of some homes south of South Avenue.

- 1-5 Infill construction footprints should generally be parallel to lot lines. Residential structures should not be placed at odd angles to the street and neighboring properties.
- 1-6 Some homes south of South Avenue and east of Rio Linda Boulevard have spacious front and rear yards with homes located toward the rear of the lots. Setbacks for infill construction on lots in this area may be flexible to respect this established large lot, semi-rural character.

Sustainability Guidelines

- 1-7 Homes should be designed and oriented on the lot to maximize solar access on southern exposures so that such features as photovoltaic solar panels and daylighting can be incorporated into the design of the home, when feasible.

2 Scale and Mass

Design Principle

An infill home should be compatible with the overall scale and mass of other homes on the block. An addition to an existing home should be compatible with the scale and mass of the existing home, as well as with the scale and mass of other homes on the block.

Rationale

Although new infill homes and additions to existing homes are addressing demand for more square footage, they also should respect earlier, established homes by minimizing the appearance of bulk and mass through site layout and architectural design.

Design Guidelines for Infill Construction

- 2-1 Homes on long, narrow lots should be oriented perpendicular to the street to minimize the appearance of mass.
- 2-2 The mass of a larger structure should be broken down into smaller components that are similar in scale to other buildings in the neighborhood.

Design Guidelines for Additions

- 2-3 Additions should respect the massing, scale, and height of the primary structure.
- 2-4 Additions that are taller than the original building should be located at the rear of the building so that the new addition does not visually overpower the original structure.
- 2-5 Large additions should be broken down into smaller, varied components that relate to the scale and massing of the original structure.

Sustainability Guidelines

- 2-6 Solar access for daylighting and solar panels should be considered in massing design. Glazing should be located predominantly on the north and south sides of the structure. Glazing on the west side of the structure should be minimized, unless the west side of the structure is the street side.

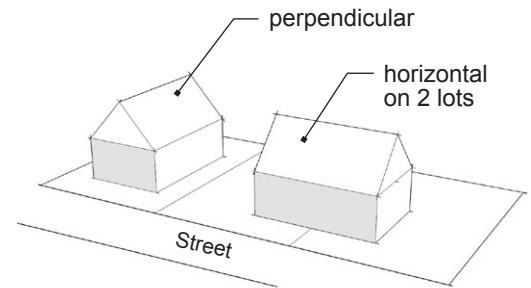

Orient homes on small lots perpendicular to the street. These buildings have identical square footage, but the home on the left appears smaller because it is perpendicular to the street.



The facade of this home has been broken down into smaller components to reduce the appearance of mass.

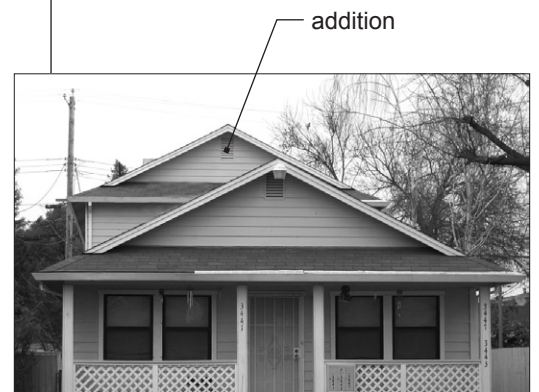

Additions should be located at the rear so as not to overpower the original structure.

Single-family Residential



Architectural details and articulated facades can help to minimize the appearance of two-story infill homes.



Bay or bow windows can help to articulate a residential facade as exemplified in these two-story duplex units.



Dormer windows and other decorative roof elements help to break up the mass of a two-story home.

3 Number of Stories

Design Principle

Two-story homes are acceptable in areas where one-story homes predominate, but they should be designed to minimize the appearance of mass of the second story.

Rationale

Although many streets in Del Paso Heights have the occasional two-story home, the majority of homes are one story. Because two-story infill structures have the capacity to appear out of scale with other homes on a block, they should be carefully designed so as not to overwhelm adjacent one-story homes.

Design Guidelines

- 3-1 The front of the home should not present an unbroken two-story wall to the street. Facades should be articulated to break up the surface, add interest, and minimize the appearance of mass. Articulation should include at least two of the following features:
 - protruding or recessed facade surfaces
 - bow, bay, or dormer windows
 - horizontal elements such as cornices, window lintels, or horizontal bands
 - porches or porticoes
- 3-2 All sides of the homes should be given visual interest through the careful placement of windows, while also protecting the privacy of the adjacent home. No side of a two-story home should present an entirely blank facade.
- 3-3 Porches and porticoes should be one story in two-story homes to maintain the proportion and context of the surrounding homes on the block (see Category 8, "Entry Features").
- 3-4 Architectural elements, such as dormers, multiple gables, and windows, should be added to the second story to impose articulation on the facade, as feasible.
- 3-5 Infill duplexes constructed on narrow lots (40 feet wide or less) should be designed as two-story stacked units. These structures should conform to the same principles outlined above, with articulation of the facade and the addition of architectural elements.

4 Garages

Design Principle

The garage should be placed at the side or rear of the home to minimize its visibility from the street.

Rationale

Many existing homes in Del Paso Heights have been designed with the garage extending from the front of the home. New garages on infill homes should not follow this established pattern, but should be recessed behind the front facade at the side or rear of the home.

Design Guidelines

- 4-1 Garages shall conform to all relevant City regulations and guidelines, including the City Municipal Code Section 17.80.040, "Residential Accessory Structures and Use Regulations."
- 4-2 On-site parking may be an attached or detached garage. Attached garages should be recessed a minimum of 3 feet behind the front facade (the main front wall) of the home. However, garages that are recessed 3 feet behind the front of the porch will be considered on a case-by-case basis.
- 4-3 Garages should be recessed a minimum of 3 feet behind the front facade.
- 4-4 Alley access to garages in Del Paso Heights is discouraged, but will be evaluated on a case by case basis.
- 4-5 Garage design, siding, roofing, trim, and window materials should match the character and materials used on the primary residence.
- 4-6 City Municipal Code permits a carport if 50% or more of the dwellings on the block do not have enclosed parking. The carport should be designed to the same standards as an enclosed garage, with similar roofing materials and roof pitch.
- 4-7 The simplest, least adorned garage door that can be used is a raised panel metal sectional door.

Sustainability Guidelines

- 4-8 Single-car garages or tandem garages are encouraged to reduce the extent of paved driveway areas.



Detached garage at the rear of a home



Attached garage recessed from the front facade of the home

Single-family Residential



Parking in Del Paso Heights is often at the front of the home on a driveway. Infill homes should minimize driveways and parking at the front facade of the home through recessed garage placement.



Alternative driveway materials, such as turf strips, can minimize the amount of paving in driveways.

5 Parking and Driveway Location

Design Principle

On-site parking should be located at the side or rear of the lot, whenever feasible, to minimize parking along the facade facing the street and afford an unobstructed and attractive view of the home.

Rationale

Many homes have been designed with extensive driveways and parking at the front of the home. Infill development should place driveways and parking toward the side of the lot so that the front yard is visually attractive and can be landscaped.

Design Guidelines

- 5-1 Parking shall conform to all relevant City regulations and guidelines, including the City Municipal Code Section 17.64.020, "Parking Requirement by Land Use Type," which states that one off-street parking space is required per dwelling unit.
- 5-2 Shared driveways between two adjacent lots are encouraged, where feasible, to minimize the paved area at the front of the home.
- 5-3 Concrete and asphalt are typical driveway paving materials. Alternative driveway paving surfaces, such as mortared brick or concrete pavers, or tinted concrete, are encouraged to minimize the appearance of a monotonous paved front yard. Permeable materials, such as pavers, cobblestone, or similar treatments, are also recommended paving materials for driveways. Driveway strips with turf between the strips are another desirable alternative. Alternative treatments must be approved by the relevant reviewing agencies per City development standards for paving surfaces.

ARCHITECTURAL ELEMENTS

Architectural elements include the detailing of the home, such as roofing, siding, windows, and doors. Infill homes and additions or renovations to existing homes should respect the architectural style of established homes on the block, while also reflecting contemporary construction methods.

The home shown below was approved and constructed prior to the development of these Design Guidelines; therefore it does not have some recommended architectural features, such as a recessed garage. However, the design of the home successfully complements the style, scale and materials of nearby homes in the neighborhood.

All architectural elements should be constructed of high-quality materials to promote longevity and a pleasing appearance. Variety of design and materials is desirable if complementary to the existing neighborhood context.



This newer infill home has been designed to fit in with the prevailing architectural design of the surrounding homes.

Single-family Residential

6 Architectural Character and Detailing

Design Principle

An infill home should be designed in a cohesive architectural style that complements the best examples of existing residential development on the block.

Rationale

Structures that are compatible with existing homes contribute to a sense of place and add to the character of the neighborhood. Use of character-defining features, such as porches, columns, balustrades, brackets, rafters, and decorative trim, enhances visual compatibility.

Design Guidelines

- 6-1 The architectural design of infill construction should complement the architectural styles of existing homes on the block. If there is a mixture of styles on a block, then the design of infill construction may be more flexibly interpreted.
- 6-2 Architectural features and detailing should be proportional to the scale of the home, as well as to other homes on the block of a similar architectural style.
- 6-3 Additions should be designed with architectural details that are similar to those of the existing structure, but simpler and visually distinguishable.
- 6-4 A contemporary sundeck may be added to an existing structure, provided that it does not visually detract from the main building. The scale, material, color, and details of the deck should be compatible with the existing building. Removal of significant features of the existing building, such as a porch, is strongly discouraged.
- 6-5 Individual architectural elements of the home should be consistent with the structure's overall design.
- 6-6 All elevations should be given equal design treatment and architectural consideration.



This renovated home has architectural details scaled to the proportions of the home.

7 Roof Styles

Design Principle

The design of a roof on an infill home should correspond to the prevailing designs of roofs on homes in the established neighborhood context. The design of the roof on additions and renovations should correspond to the roof style and pitch of the existing structure.

Rationale

The pitch, style, and orientation of the roof in an infill home should be similar, but not necessarily identical to, the roof styles of existing homes on the block to encourage respect for the established context while allowing for variety.

However, the pitch, style, and orientation of the roof on a renovation or addition should be identical to that of the existing home, while any crossing gables should match the established pitch and style of the existing roof.

Design Guidelines

- 7-1 Roof design on infill structures should be similar to the shape, pitch, overhang, and material of the roof design of existing homes on the block.
- 7-2 Flat roofs are discouraged and should be used only if they are common in neighboring residences.
- 7-3 Infill homes should respect the primary gable orientation of the majority of existing homes on the block.
- 7-4 The roof forms and slopes of additions should be similar to those of the original structure. The roof of the addition should be subordinate to that of the primary building. Gable, hip, and shed roofs are appropriate for additions.
- 7-5 A dormer addition should be subordinate to the scale of the primary structure. The number and size of dormers should not be visually overwhelming. The new dormers should be placed below the ridgeline of the primary roof.

Sustainability Guidelines

- 7-6 Roof overhangs ranging from 18 to 36 inches are encouraged to promote window shading and building longevity when appropriate to the architectural design of the home.



Gable roof with front-facing gables



Gable roof with side-facing gables and shed-roofed dormer windows



Gable roof with clipped end

Single-family Residential



Attractive porch detailing complements home

8 Entry Features

Design Principle

Infill homes and additions to the front facade of the home should have an entry feature such as a porch or stoop that faces the street side.

Rationale

Entry features accent the front facade of a home and add visual interest. Entry features and their components, such as columns and steps, should be proportional to the overall scale of the home.

Design Guidelines

- 8-1 Entry features are encouraged on all new infill homes, and are a recommended renovation for existing homes, where feasible.
- 8-2 Entry porches and porticoes in two-story homes should be one story to minimize the appearance of bulk.
- 8-3 Entry features should be built to a depth of 6 feet from the front of the entry feature to the front facade of the home; however, shallower entry features will be considered on a case-by-case basis.
- 8-4 The style of porch and portico elements should be consistent with the scale and style of the home, and should strive to respect the scale and style of porch and portico elements in the other homes on the block.
- 8-5 Porch and portico columns should be given some form of detailing, such as a defined plinth and capital.
- 8-6 Porch columns and railings should be constructed of high-quality materials that complement the materials used in the overall exterior of the home.



Entry clearly visible and single-story porch proportional to the home



Columns scaled to home with appropriate detailing

9 Doors

Design Principle

Doors should be made of high-quality materials and include decorative elements such as raised panels, sidelights, and transoms that are appropriate to the overall design of the home.

Rationale

Doors are an important architectural feature that offer security and visual appeal. For this reason, doors should be made of high-quality materials that protect the home, while also offering aesthetic appeal through decorative elements that correspond to the style of the home.

Design Guidelines

- 9-1 Doors are character-defining features of a home and should be appropriately designed to contribute to the overall composition of the house.
- 9-2 Doors should not be flat surfaces, but should include raised panels, glass, or some other form of detailing and articulation.
- 9-3 Doors should be of high-quality materials, such as metal or solid-core wood.
- 9-4 Doors may be metal or wood-framed. High-quality metal framing can afford enhanced security and fire protection and should be considered. Whether wood or metal, door framing should be slightly recessed or extended to lend interest and definition to the entry.



Door with sidelights, transom, and raised panels

Photo Courtesy of DesignLens



Door with sidelights and inset panels

Single-family Residential



Window detailing, such as shutters, adds interest.

Photo Courtesy of DesignLens



Casement window with wooden frame and sill



Single-hung windows with wooden frame



Attractive window detailing

Photo Courtesy of DesignLens

10 Windows

Design Principle

Windows should be constructed of high-quality materials and designed to complement the style of the home.

Rationale

High-quality materials and construction techniques should be used to ensure the longevity of windows and enhance their aesthetic appeal.

Design Guidelines

- 10-1 Windows should complement the style of the home. Recommended window styles include casement, single-hung sash, and double-hung sash windows.
- 10-2 Windows with multiple panes provide interest and definition to a home's facade and are encouraged.
- 10-3 Window frames, sash, trim, and sills may be wood, vinyl, or a paintable fiberglass composite. Unpainted metal is not allowed.
- 10-4 A consistent window treatment should be used on all sides of the building.
- 10-5 Reflective or tinted glass and opaque plastic skylights are discouraged.
- 10-6 Windows used in new additions and remodels should be similar to those in the primary structure.

Sustainability Guidelines

- 10-7 The use of insulating glazing such as LoE² is encouraged to increase energy efficiency.
- 10-8 Prismatic glazing is encouraged to increase the energy efficiency of skylights.
- 10-9 Daylighting should be incorporated into the architectural design of the home, where feasible, to increase energy efficiency.



Daylighting increases energy efficiency.

11 Siding

Design Principle

The siding used on an infill home or addition to an existing home should be durable, consistent with the style and character of the home, and complement the siding materials used on other homes on the block.

Rationale

Siding, and other forms of architectural cladding, should not only complement the style of new infill homes, but should be consistent with siding materials commonly used on other homes in the neighborhood to avoid appearing out of context. Siding used on additions should match siding on the existing home to the greatest extent possible.

Design Guidelines

- 11-1 The architectural cladding should be consistent with the majority of the homes on the block.
- 11-2 The architectural cladding should be used consistently on all sides of the house.
- 11-3 Where lap siding is the predominant form of siding on the block, it should be used for infill construction as well.
- 11-4 Wood lap siding should be applied horizontally and should be similar in scale, proportion, texture, and finish to the wood lap siding traditionally used on the block. Other types of siding, such as flush siding and drop siding, are acceptable if they have precedence in other homes on the block.
- 11-5 Several lap siding materials are available, with some recommended over others:

Recommended:	Discouraged:
Wood	Vinyl
Cement fiber	T1-11
	Aluminum
- 11-6 Where lap siding is not the predominant material, wood, brick, stone, and stucco are also acceptable materials.
- 11-7 Stucco must be smooth, troweled plaster. Spray-on, "popcorn" stucco is not allowed, and foam trim sprayed with stucco should be avoided.
- 11-8 The use of two materials, with one employed as wainscoting, can often add to the interest of the home.
- 11-9 Highly reflective metals, glass, plastic, and vinyl should be avoided.



Wood lap siding

© 2005 JupiterImages Corporation



Smooth Stucco



Brick



Brick wainscoting on smooth stucco

Single-family Residential



Laminated dimensional shingles

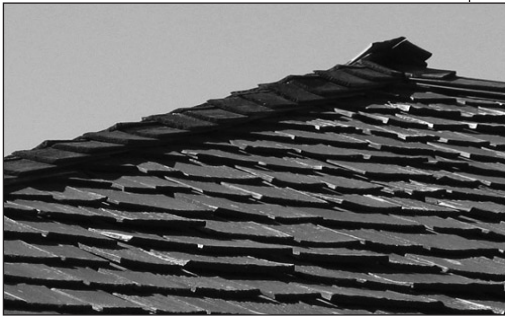

Wood shakes



Lightweight concrete shingles

12 Roofing

Design Principle

Roofing on an infill home should be durable and complement the style of the home. Roofing on an addition or renovation should be durable, and complement the roofing on the existing home.

Rationale

Roofing materials should be durable to ensure their attractiveness and continued functionality for many years. Roofing materials should also be suitable for the context. For example, high-quality metal roofing may be appropriate in some rural or resort settings, but is uncommon in the Del Paso Heights neighborhood and therefore inappropriate.

Design Guidelines

- 12-1 Roofing materials must have a minimum 30-year guarantee. Roofing with a 40-year guarantee is encouraged.
- 12-2 The color and materials used for roofing should complement the color and architectural style of the home. Accent colors may be used, but they should not overwhelm the home, or clash with other homes on the block.
- 12-3 The following materials are recommended:
 - laminated dimensional (asphalt) shingles;
 - wood shingles/shakes;
 - laminated dimensional fiberglass shingles;
 - lightweight concrete shingles;
 - terra cotta tile or lightweight concrete tile; or
 - slate shingles.

Exceptions to these roofing materials will be made on a case-by-case basis.

Single-family Residential

- 12-4 Metal roofing is typically inappropriate and highly discouraged.
- 12-5 Composition shingles should only be rolled over side barge boards when appropriate to the overall design of the structure.
- 12-6 When installing gutters, rafter tails should only be trimmed when the rafter tail design is not an architectural feature specific to the overall design of the structure.

Sustainability Guidelines

- 12-7 Photovoltaic solar panels or solar shingles such as “solar slate” are encouraged to reduce the home’s use of energy from conventional sources.
- 12-8 Homeowners are encouraged to consider roofing options that include recycled content.
- 12-9 The use of “cool roof” options, including lighter colored roofing and reflective coatings, is encouraged to achieve energy efficiency.



Tile shingles



“Cool roof” options can achieve higher energy efficiency.

Photo Courtesy of Met Tile

Single-family Residential



Simple, streamlined lighting fixtures can complement a wide variety of home styles.



High-quality lighting fixtures can enhance the appearance of the home.



Addresses should be illuminated and easily visible from the street.

13 Lighting and Addresses

Design Principle

Light fixtures should be consistent with the architectural style of the home and should provide adequate illumination of the front entry and addresses so that both are clearly visible from the street.

Rationale

To assist emergency vehicles and contribute to the safety of the home, address lettering should be affixed near the door and should be large enough to be seen from the street. Lighting fixtures should be adequate to illuminate the addresses and the front entryway.

Design Guidelines

- 13-1 Lighting contributes to the security of the home and is required for the front entry, walkways, and garage area. Recessed entryways should be clearly lit.
- 13-2 Lighting fixtures should be designed for exterior use and should be weather resistant.
- 13-3 The address should be illuminated and clearly visible at night.
- 13-4 The address should be visible from the street.
- 13-5 Address numbers should be 4-8 inches high.
- 13-6 The preferred location to display the address is affixed to the front of the home, adjacent to the front door. If structural considerations preclude affixing the address adjacent to the front door, then the address may be attached on the front of the home or garage as long as it is still clearly visible from the street and illuminated at night.

Sustainability Guidelines

- 13-7 Compact fluorescent bulbs and photocell sensors are encouraged to achieve energy efficiency.

Single-family Residential

SITE ELEMENTS

Site elements include those features that are auxiliary to the home, such as landscaping, fencing, and paving. Site elements are typically used to enhance the appearance and functionality of the home.

High-quality site elements can increase the beauty and value of the home, and when carefully selected, can also contribute to the visual continuity of the street.



This newer home has fencing that complements the architectural style of the home and trash containers and utilities that are not visible from the front of the home.

Single-family Residential



Groundcovers, such as this Vitex species, can provide a low-water alternative to turf.



Landscaped areas should be mulched with bark or stone.

14 Landscaping

Design Principle

Landscaping should be used on the site to positively contribute to the appearance of the home and site and to create a sense of visual continuity along the street. The front yard should be planted with landscaping materials that may include a mixture of turf, groundcover, and decorative shrubs.

Rationale

Use of a variety of landscaping plants and materials can help create visual interest and define the character of the neighborhood. Trees provide shade, reduce energy consumption in the summer, help to filter air pollution, and can increase property values.

Design Guidelines

- 14-1 Landscaping shall conform to the City Municipal Code Section 17.68.010, "Landscaping requirements," which states that a maximum of 40% of the front yard setback may be paved for parking and driveways, with an additional 10% for walkways or uncovered patio use. The remaining portion of the yard must be landscaped.
- 14-2 Alternatives to turf, such as groundcovers that can tolerate foot traffic, are encouraged.
- 14-3 A minimum of two trees should be planted in the front yard. A minimum of three trees should be planted for homes on corner lots where the yard permits full canopy growth.
- 14-4 Bare soil should be planted or mulched with bark, stone, or other suitable materials to avoid unnecessary runoff.
- 14-5 Street trees should be retained. Consult the City Parks and Trees Service at 916-808-5200 for questions regarding the care of street trees. Private tree services are available for consultation before trimming or removal of mature trees on private lots.

Single-family Residential

- 14-6 Refer to the following lists for more information about recommended species:

Sacramento Tree Foundation

www.sactree.com/treelInfo/treesWeOffer.html

Sacramento Municipal Utility District (SMUD)

www.smud.org/residential/saving/trees/index.html

City of Sacramento Department of Parks and Recreation

www.cityofsacramento.org/parksandrecreation/urbanforest/index.html

- 14-7 Street trees and plant species should be suitable for the Sacramento climate. Low-water landscaping materials are encouraged.
- 14-8 Trees species should be selected so that each tree's canopy at full growth can be accommodated by the site. A variety of tree species representing a range of sizes will contribute to the visual interest of the yard and is recommended.

Sustainability Guidelines

- 14-9 Homeowners are particularly encouraged to plant deciduous shade trees and shrubs that shade the west and south sides of the home to minimize solar heat gain and increase energy efficiency.
- 14-10 Shade trees should be planted to shade pavement areas to reduce heat transmission and energy consumption.
- 14-11 New planting strips located between the sidewalk and street should be a minimum of 6 feet wide to promote the health of shade trees.



Native and low water use ornamental plants can significantly reduce water consumption.

Single-family Residential



A conventional spray system is most effective for turf and groundcover.



A drip irrigation system provides deeper watering for shrubs and trees.

15 Irrigation

Design Principle

Irrigation is essential to maintain the health and beauty of a home's landscaping and should be provided for all infill homes.

Rationale

The seasonal extremes of the Sacramento climate make regular irrigation of planted areas mandatory. Automatic irrigation ensures regular and consistent watering, and promotes healthy landscaping.

Design Guidelines

- 15-1 An automatic irrigation system should be installed in the front yard to provide consistent coverage of all planted areas. A home on a corner lot should have an automatic irrigation system that covers the yards fronting both streets. Automatic controllers with rain shut-off valves provide greater water conservation.
- 15-2 If there is a front planting strip, the homeowner is responsible for the irrigation and maintenance of it.
- 15-3 Turf and groundcover are more effectively irrigated with a conventional spray system. Head-to-head spray coverage is recommended. Avoid overspray onto sidewalks and adjacent properties.
- 15-4 A drip irrigation system is recommended for shrubs and trees to provide deeper, more even watering. Drip irrigation also permits greater water conservation than a conventional spray system.
- 15-5 Irrigation controls must be screened from view by landscaping or other attractive site materials.

16 Fencing

Design Principle

Fencing must be of high quality materials that are consistent with the style of the home to enhance the overall character of the home and contribute to the positive appearance of the neighborhood.

Rationale

Fencing should be selected to complement the character of the home as well as the overall character of the neighborhood. Front yard fencing should be selected not simply as a security measure, but for its decorative qualities.

Design Guidelines

- 16-1 Fencing shall be located and constructed in conformance with the City Municipal Code Section 15.156, "Fences," and Section 17.76, "Wall, Fence and Gate Regulations." Per Section 17.76, fencing on the front or side yard adjacent to a street of residential properties shall not exceed 4 feet in height, unless it is made of wrought iron or tubular steel, in which case the fencing may be up to 6 feet in height. However, to increase the aesthetic appeal of the Del Paso Heights neighborhood, these Design Guidelines discourage the installation of fences over 4 feet in the front or side yard adjacent to the street.
- 16-2 Fencing must allow unobstructed visibility of the front entrance, and in the case of homes on corner lots, the front and side entrances, to promote visual surveillance of the front yard and aid in crime prevention.
- 16-3 Front yard fencing should have a minimum of 50% transparency.
- 16-4 The style, materials, and color of the fencing should complement the style, materials, and color of the home.
- 16-5 High-quality materials, including wood, metal, stucco, and some forms of vinyl fencing are acceptable fencing materials. Stucco must be smooth plaster.
- 16-6 Chain link fencing is highly discouraged for use as a front yard feature. Solid stucco walls are also discouraged, but stucco may be used in conjunction with other materials.

Sustainability Guidelines

- 16-7 The use of chlorine-based vinyl fencing is discouraged.



A tall hedge that provides a good place for intruders to hide should be avoided.



Wooden fence with 50% transparency



Metal fence with brick column

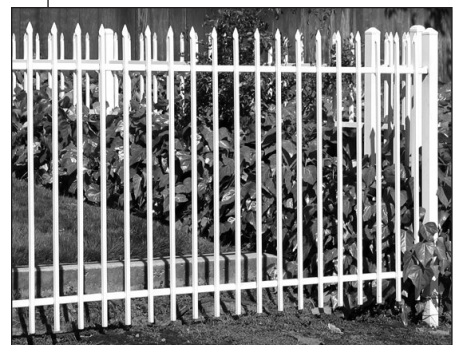

Metal fence with ornamental top

Single-family Residential



Brick set on sand and gravel base



Flagstone mortared on concrete

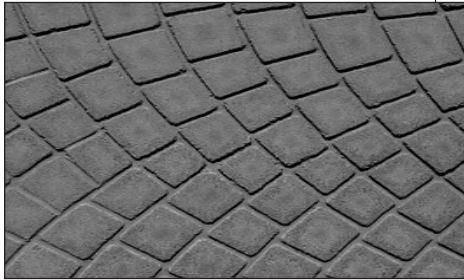

Patterned Concrete



Stone with turf areas between blocks

17 Paving/Hardscape Surfaces

Design Principle

The paving materials selected should contribute to the overall appearance of the home. Impervious paving surfaces should be minimized, and limited to the driveway, walkways, and patios.

Rationale

Large impervious surfaces constructed of concrete or asphalt should be minimized at the front of the home. Instead, alternatives, such as brick, stone, concrete pavers, and patterned concrete, should be used as appropriate. Some of these alternative forms of paving can offer the added benefit of minimizing stormwater run-off and the need for supplementary irrigation, as water is able to percolate down through the spaces between paving units.

Design Guidelines

- 17-1 Paved areas shall not exceed those defined by City Municipal Code Section 17.68.010, "Landscaping requirements," which states that a maximum of 40% of the front yard setback may be paved for parking and driveways, with an additional 10% for walkways or uncovered patio use.
- 17-2 Alternative paving surfaces, such as concrete pavers, brick, or stone are encouraged for driveway surfaces to reduce the appearance of large, paved areas.
- 17-3 Alternative paving surfaces that help to keep stormwater runoff on-site are encouraged.

18 Utilities and Storage Facilities

Design Principle

The visibility of utilities and storage facilities should be minimized by placing them at the side or rear of the home and screening them from view from the street.

Rationale

Utilities and service features are less attractive but necessary parts of the home. These features should be placed at the side or rear of the home, and screened by fences and landscaping. Alley access can facilitate placement of and access to these features at the rear of the home.

Design Guidelines

- 18-1 Trash receptacles should be placed in the side or rear yard and adequately screened by landscaping or a side yard fence.
- 18-2 Storage sheds should be located in the rear yard. Placement in the side yard is acceptable if the shed is adequately screened by landscaping or a side yard fence.
- 18-3 Accessory structures should be similar in character and materials to the main building, but subordinate in massing, scale, and height.
- 18-4 Antennae should be mounted at the rear of the home. Satellite dishes should be mounted on the home to minimize their visibility.
- 18-5 Heating and cooling units should not be roof-mounted or placed at the front of the home. Heating and cooling units should be placed in the attic or at the side or rear of the home and screened by a side yard fence or landscaping. Solar panels do not need to be screened.

Sustainability Guidelines

- 18-6 Where feasible, heating, ventilation, and air conditioning units should be placed on the north side of the primary structure or garage (if not the street side) to shade the units and minimize energy consumption.



This utility box should be screened by taller growing plants.



A conspicuous antenna is highly discouraged.

19 Access Ramps

Design Principle

Ramps that provide access to the front or side of the home should be safe, designed to match the style of the home, and constructed of durable materials that complement those used on the home.

Rationale

Ramps that provide universal access to single-family homes should be designed so that they look like they are a part of the home to the greatest extent possible. The ramp should be designed to minimize its size and bulk without compromising safety and ease of access. Materials used should complement those used on the home, i.e., a concrete ramp with brick facing could be used on a brick home, while a wooden ramp might be more suitable for a home with wood lap siding.

Design Guidelines

19-1 Any ramp providing access to a single-family residence should be designed to meet standards found in the Americans with Disabilities Act, available for review at:

www.ada.gov/stdspdf.htm

Under ADA standards, a ramp should be designed with a slope ranging between 1:12 and 1:20 (5 to 8% slope), and should include 60-inch landings at the top and bottom of any run. A handrail should be included on all ramps higher than 6 inches.

19-2 The ramp should be designed so that it does not detract from existing architectural elements at the front of the home. The specific location and angle of the ramp may vary, depending on the design of the home and its location on the lot.

19-3 Ramps should be constructed of sturdy, long-lasting materials, such as wood, brick, or concrete. Ramp materials should complement those used on the home. Where appropriate, facing materials used on the home may be affixed to the side of the ramp.

19-4 Modular aluminum ramps are discouraged from use at the front of the home.

Multi-family Residential

The Multi-family Residential Design Guidelines outline good design practices for infill multi-family development (defined as residential structures with three or more units). Del Paso Heights has limited existing multi-family development. Future multi-family development near established single-family homes should complement those homes without appearing too massive or out of scale. Multi-family development in the vicinity of Marysville Boulevard may be designed to complement nearby commercial development.



This multi-family development has been designed with architectural features similar to those in single-family homes.

Multi-family Residential

SITE DESIGN

This section discusses the location of multi-family structures on the lot, their orientation toward the street and adjacent buildings, and the location of parking lots and parking structures,

Good site design of multi-family structures should ensure that residents can easily access them from the street, with entryways clearly located on the street side. Parking areas, utilities, and service facilities should be located toward the rear of the site. Common spaces should be toward the interior of the site so that all residents can easily access these facilities, and to provide additional safety for small children.

Setbacks for multi-family structures should be similar to those of established structures in the area. If the established context consists of single-family homes, multi-family structures should have similar setbacks, and the design of the multi-family structures should minimize the mass of the buildings. Multi-family structures located in or near commercial districts may have smaller setbacks similar to those of commercial buildings.



A multi-family structure with defined entries, gates, and paths.

Multi-family Residential

20 Relationship to the Street

Design Principle

Multi-family structures should present a facade that encourages interaction with the street by including entry features, windows, and landscaping along the street side of the building.

Rationale

Multi-family structures that are adjacent to a public street should encourage residents to actively engage with that street through a variety of design elements. In addition to improving the visual quality of the streetscape, design elements should allow residents to see and be seen from the street, enhancing neighborhood interaction and improving safety.

Design Guidelines

- 20-1 Multi-family structures that present a blank wall to the street are not allowed.
- 20-2 Multi-family structures that are constructed as infill near an existing single-family residential neighborhood should provide a streetside facade that is complementary to these single-family homes in style and massing.
- 20-3 Multi-family structures should have entry features that front onto the street, including a door and porch or stoop that relate directly to the street frontage.
- 20-4 Recessed entry features are strongly discouraged. Residents should be able to see and be seen as they enter and exit their residences.
- 20-5 Streetside windows should be installed that provide views of the street from active living spaces.
- 20-6 Small, landscaped private entry yards afford an attractive appearance on the street side and allow residents to control and take pride in these areas.
- 20-7 Pedestrians should have clear, unobstructed access to the street and to nearby transit stops.
- 20-8 Paths and access points should be clearly visible during the day and well lit after dark.

Sustainability Guidelines

- 20-9 Street trees should be planted within planting strips and yards to provide shade and increase energy efficiency.

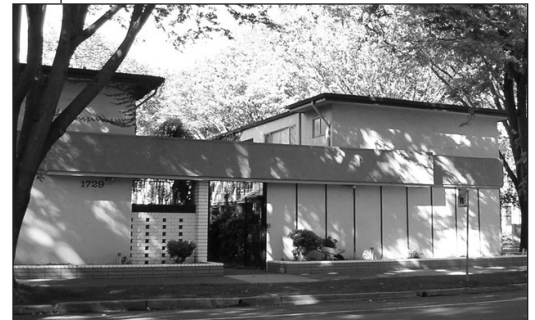

Blank walls facing the street are not allowed.



Private front yards that are visible to the street can help residents to see and engage with the public realm.

Multi-family Residential

21 Setbacks

Design Principle

Setbacks of multi-family residential structures should reflect the appropriate commercial or residential context.

Rationale

When multi-family residential structures are placed on busy commercial streets, smaller setbacks that locate the building closer to the street are the norm. Multi-family structures constructed near single-family residential neighborhoods should reflect the larger setbacks typically found in those areas.

Design Guidelines

- 21-1 Large multi-family developments should be designed with varied setbacks that contribute to an interesting streetscape and avoid a monotonous streetwall. Continuous lines of buildings with the same setback should be avoided.
- 21-2 Individual buildings can also be designed with an articulated front, with porches closer to the street than recessed garages.
- 21-3 In residential neighborhoods, multi-family housing should adopt the predominant setback, but should also vary the building facade to relieve the appearance of mass.



These multi-family homes have been designed with setbacks and architectural features similar to those found in single-family homes.



This contemporary multi-family development has been designed with setbacks similar to adjacent commercial development.

Multi-family Residential

22 Interior Common Spaces

Design Principle

Multi-family structures should provide interior common spaces that are easily accessible. Individual units adjacent to common spaces should have facades with entry features and windows that open onto those common spaces.

Rationale

Interior common spaces should ideally foster a sense of community. This can be facilitated by building facades that allow residents to see and easily use common spaces. Common spaces should offer amenities that invite use, such as seating, shade, and tot lots.

Design Guidelines

- 22-1 Ground floor units should have doorways that open onto interior common spaces.
- 22-2 All units that overlook interior common spaces should have windows that allow residents to easily see these areas.
- 22-3 Common amenities, such as tot lots, seating areas, and swimming pools, should be provided that cater to all age ranges, from small children to the elderly, as appropriate.
- 22-4 Common facilities such as recreation rooms, and laundry and mail areas should be located adjacent to common open space to increase activity in these areas.
- 22-5 Common open space should be designed as a visible, accessible transition between the street and individual units.



Interior common spaces can offer seating and areas for informal activities.



This multi-family complex has an inviting interior common space with picnic area.

Multi-family Residential

23 Scale and Mass

Design Principle

Multi-family residential structures should be consistent with the scale and mass of existing structures in the vicinity.

Rationale

Multi-family development should use design and construction methods that minimize the appearance of mass with multiple rooflines, articulated facades, and architectural detailing that break up the facade.

Design Guidelines

- 23-1 Multi-family structures that are constructed as infill near an existing single-family residential neighborhood should provide a streetside facade that is complementary to these single-family homes in style and massing.
- 23-2 The second story on two-story structures should be articulated to break up the facade and minimize the appearance of mass.
- 23-3 Two-story structures should have multiple rooflines with corresponding gables that are consistent in style and materials with the overall structure.
- 23-4 Architectural detailing, such as dormer and other types of decorative windows, complementary trim, porch details, decorative shutters, and wainscoting, can reduce the appearance of bulk and mass by providing visual interest.

Sustainability Guidelines

- 23-5 Whenever possible, buildings should be oriented on the site to maximize solar access on southern exposures so that features such as photovoltaic solar panels and daylighting can be incorporated into the architectural design.
- 23-6 Solar access for daylighting and solar panels should be considered in massing design. Glazing should be located predominantly on the north and south sides of the structure. Glazing on the west side of the structure should be minimized, unless the west side of the structure is the street side.



Multiple roof lines can reduce the appearance of mass in large multi-family structures.



The facade of this multi-family structure has been designed with architectural detailing to add interest and reduce mass.

Multi-family Residential

24 Parking Lots

Design Principle

Parking should be located at the rear or interior of the complex, where feasible. Parking lots that face the street or are on the side of multi-family housing should be minimized.

Rationale

Multi-family residential structures should encourage residents to have an active relationship with the street(s) adjacent to the development. To this end, parking lots should be located at the rear or in the interior of the development so as not to interfere with access to the street or interior common spaces.

Design Guidelines

- 24-1 Parking lots shall conform to City Municipal Code Section 17.64.030, "development standards for parking facilities," which specifies stall size and design.
- 24-2 Smaller, scattered lots will provide better access to residents and be less visually obtrusive than a single large lot.
- 24-3 Covered parking should be located so that it does not interfere with front entries or access to interior common spaces.
- 24-4 Parking areas should be screened from adjacent structures with landscaping strips. However, screening should not exceed 4 feet in height, and should be permeable so that areas can be viewed by passing pedestrians and vehicles.
- 24-5 Underground parking in private or shared garages accessible from the street is acceptable if it does not interfere with pedestrian access to the street.



These units face the street, while parking is located at the rear of the building.



Parking is in small, dispersed lots in the interior of this multi-family development. The materials on the carport also match those on the main buildings.

Multi-family Residential

ARCHITECTURAL ELEMENTS

This section addresses the specific structural elements that can contribute to the positive appearance of multi-family housing.

All architectural elements should be constructed of high-quality materials to promote longevity and a visually pleasing appearance. Variety of design and materials is desirable if complementary to the existing neighborhood. If located in an established residential neighborhood, multi-family housing should be designed with architectural features that complement the character of adjacent single-family homes.



These townhomes have facade details and colors that distinguish them as individual units.

Photo Courtesy of DesignLens

Multi-family Residential

25 Garages

Design Principle

The visibility of multi-family garages from the street should be minimized. Instead, garages should be located beneath, at the side, or at the rear of multi-family structures. Garage and carport materials and architectural styles should complement the materials and styles of the primary buildings.

Rationale

To minimize the visual prominence of garages, they should be placed underneath or at the rear of multi-family structures. Garages should be grouped in small clusters rather than unbroken lines.

Design Guidelines

- 25-1 Garages should be varied in their location to minimize the impact of a row of garage doors.
- 25-2 Rows of garages or carports around the perimeter of a development should be avoided.

Sustainability Guidelines

- 25-3 The use of photovoltaic solar panels on carports is encouraged.
- 25-4 Garages and parking structures should incorporate tandem parking whenever feasible to reduce the extent of paved driveway areas.
- 25-5 Reduced alley aprons are encouraged to decrease pavement runoff.



The garages are located at the rear of this multi-family structure.

Multi-family Residential

26 Entry Features

Design Principle

The principal entry to each unit should be clearly visible from the street and include a porch, stoop, or other entry feature.

Rationale

To give definition to the facade of multi-family structures and provide visual interest, entryways should be defined by entry features such as a porch, stoop, portico, or overhang.

Design Guidelines

- 26-1 Entryways to each individual unit should include some form of entry feature, such as a porch or portico, that adds visual interest to the overall structure.
- 26-2 To promote visibility and security, front doorways should not be recessed to the extent that they are not clearly visible.
- 26-3 The style of porch and portico columns should be consistent with the scale and style of the building.
- 26-4 Porch columns and railings should be constructed of high-quality materials that complement the materials used in the overall structure.



Landscaped entry area, steps, and a small porch have been constructed for each unit in this multi-family structure.



The entryways in these contemporary units are marked by a change of material - high quality wood paneling - that contrasts with the adjacent stucco.

27 Lighting

Design Principle

All common areas and accessways should be adequately lit during low-light periods. Light fixtures should complement the architectural style of the home.

Rationale

Lighting fixtures should be selected with consideration for the type of use in each area of the complex. Parking lots should be adequately lit so that residents and visitors can easily negotiate parking areas. The lighting of paths and walkways should be adequate for pedestrians to walk safely without light spillover into nearby units. The design and style of light fixtures should complement the style of the buildings.

Design Guidelines

- 27-1 Lighting should be provided in all common areas, including parking, vehicular and pedestrian entries, walkways, and at common facilities such as mailboxes and swimming pools.
- 27-2 Lighting fixtures should be designed for exterior use and should be weather resistant.
- 27-3 Materials, size, color, and design of light fixtures should be consistent with the style of the structures.
- 27-4 Ornamental pedestrian lighting in common areas should not exceed 12 feet in height. Lighting for parking areas should not exceed 14 feet in height. Pedestrian lighting, such as lighted bollards, should not exceed 4 feet in height.
- 27-5 Lighting of parking lots, landscaping, and pedestrian walkways should not result in light spillover to interior residential units or adjacent homes, and should not cast glare on the public way and adjacent properties.
- 27-6 Light fixtures should be selected to attract attention to the building details instead of the fixtures themselves.
- 27-7 The lights should provide even illumination levels. Flashing or pulsating light fixtures should be avoided.

Sustainability Guidelines

- 27-8 Compact fluorescent bulbs and photocell sensors are encouraged to achieve energy efficiency.



Decorative lighting in scale with pedestrian walkway

Photo Courtesy of DesignLens



Pedestrian-scaled pathway bollard lighting

Multi-family Residential

28 Signage and Addresses

Design Principle

Entry signage should be provided at all primary access points to the complex and within the complex, as needed, to ensure wayfinding. Entry signage identifying the development and its address should be easily visible from the street to assist visitors and emergency vehicles.

Rationale

Signage promotes wayfinding, and should be easy to read from the street and well-lit at night. Signage also contributes to the character of the complex, and should complement the style and character of the buildings.

Design Guidelines

- 28-1 Interior vehicle and pedestrian circulation routes should be clearly marked by signage.
- 28-2 Individual units should have addresses with letters that are 4-8 inches high.
- 28-3 All signage should be illuminated and clearly visible after dark.



Pedestrian-scaled signage assists wayfinding in multi-family developments.



Signage with lighting (in landscaping)



Signage with landscaping and lighting

Multi-family Residential

SITE ELEMENTS

Site elements include those features that are auxiliary to the buildings, including landscaping and fencing, as well as common facilities, such as mailboxes and trash receptacles.



Lighting, landscaping, fencing, and other site elements have been carefully selected to enhance this new multi-family development.

Multi-family Residential

29 Landscaping

Design Principle

Landscaping should be provided within all streetside setbacks, common areas, and parking lots to provide shade and create visually appealing exterior spaces.

Rationale

A variety of landscaping plants and materials can contribute to the visual interest of a neighborhood. Landscaping elements should be selected not only with consideration for the style of the multi-family structures, but should also complement the landscaping of other buildings on the block.

Design Guidelines

- 29-1 Landscaping shall conform to the City Municipal Code Section 13.64.010, "Landscaping requirements," which requires that the front and street side setbacks must be planted with landscaping materials that primarily consist of turf or low-growing groundcover.
- 29-2 Trees should be planted in the setbacks and common areas at intervals appropriate to the full spread of the mature trees.
- 29-3 Bare soil should be planted or mulched with bark, stone, or other suitable materials to avoid unnecessary runoff.
- 29-4 Street trees should be retained. Consult the City of Sacramento Parks and Trees Service (916-264-5200) for questions regarding the care of street trees. Private tree services are available to consult before trimming or removing mature trees.
- 29-5 Plant species should be suitable for the Sacramento climate. Low-water landscaping materials are encouraged.



Landscaping and fencing define the common area, but interior spaces are easily seen from the street.

Multi-family Residential

- 29-6 Refer to the following lists for more information about recommended species:

Sacramento Tree Foundation

www.sactree.com/treeInfo/treesWeOffer.html

Sacramento Municipal Utility District (SMUD)

www.smud.org/residential/saving/trees/index.html

City of Sacramento Department of Parks and Recreation

www.cityofsacramento.org/parksandrecreation/urbanforest/index.html

Sustainability Guidelines

- 29-7 All planting areas, including those designed to accommodate the 2-foot overhang on parking spaces, should be landscaped with groundcover or other planting materials to reduce stormwater runoff.
- 29-8 New planting strips located between the sidewalk and street should be a minimum of 6 feet wide to promote the health of shade trees.
- 29-9 Paved and hardscaped surfaces should be shaded by trees, shade structures, or photovoltaic solar panels, when possible, to reduce heat transmission and reduce energy consumption.
- 29-10 Deciduous shade trees and shrubs should be planted on the west and south sides of buildings to minimize solar heat gain and increase energy efficiency.



Interior pedestrian path

Multi-family Residential



Irrigation spray head

30 Irrigation

Design Principle

An automatic irrigation system should be provided for new construction to maintain the health and positive appearance of all landscaped areas.

Rationale

The seasonal extremes of the Sacramento climate make regular irrigation of planted areas mandatory. Automatic irrigation ensures regular and consistent watering, and is desirable for the health of landscaping.

Design Guidelines

- 30-1 An irrigation system must be installed to provide consistent coverage of all landscaped areas.
- 30-2 Turf and groundcover are more effectively irrigated with a conventional spray system. Head-to-head spray coverage is recommended. Avoid overspray onto sidewalks and adjacent properties.
- 30-3 A drip irrigation system is recommended for shrubs and trees to provide deeper, more even watering. Drip irrigation also permits greater water conservation than a conventional spray system.
- 30-4 Automatic controllers with rain shut-off valves will allow for greater water conservation.
- 30-5 Irrigation controls must be screened from view by landscaping or other attractive site materials.



A drip irrigation system provides deeper watering for shrubs and trees.

31 Fencing

Design Principle

Fencing should complement the design of the buildings and define the boundary of the complex without obstructing physical or visual access.

Rationale

The design of fencing should be used to improve the appearance of the complex and enhance its character. Fencing should not obstruct access or visually screen the area, particularly on the street side of the complex.

Design Guidelines

- 31-1 Fencing shall conform to the City Municipal Code Section 17.76, "Wall, Fence and Gate Regulations," which states that front fencing may not exceed 4 feet in height, while side and rear fencing may not exceed 6 feet in height.
- 31-2 Fencing should be perceived as an enhancement, not a barrier, and should not obstruct pedestrian access.
- 31-3 Fencing adjacent to any street should have a minimum of 50% transparency.
- 31-4 High-quality materials, including wood, metal, stucco, and some forms of vinyl fencing, are acceptable fencing materials. Stucco must be smooth plaster.
- 31-5 Combining materials, such as metal with brick or stucco pillars, is an attractive way to give interest to fencing and is recommended.

Sustainability Guidelines

- 31-6 The use of chlorine-based vinyl fencing is discouraged.



Fencing should be a visual enhancement of the buildings.



This fencing defines the boundaries of the complex but allows easy visibility from the exterior.

Multi-family Residential



Concrete paving can be enhanced with detailing and the use of integral color.



The interlocking pavers in this shaded parking lot help to keep stormwater runoff on-site.



Pervious paving reduces stormwater runoff.

32 Paving/Hardscape Surfaces

Design Principle

Walkways and common areas should incorporate decorative paving treatments and pervious paving treatments. Parking lots should incorporate pervious paving treatments, where feasible.

Rationale

All paved areas, such as parking lots, common areas, and pedestrian walkways, can be enhanced with the use of a variety of decorative paving treatments, such as stamped concrete or concrete with integral color.

Design Guidelines

- 32-1 Impervious surfaces should be limited to driveways, parking lots, walkways, and common areas.
- 32-2 Alternative paving surfaces are encouraged for walkway surfaces in common areas, where brick, modular pavers, and various forms of stamped or integrally colored concrete are appropriate. Pedestrian walkways must balance enhanced appearance with universal access; therefore, materials such as flagstones are not appropriate for common walkways unless installed in a manner that ensures accessibility.
- 32-3 Use of permeable materials, such as permeable asphalt, grasscrete, and modular pavers, are encouraged to reduce stormwater runoff in parking lots. Where possible, drainage should be directed into planting areas to increase percolation of water runoff. Alternative paving treatments must be approved by the Building Division of the City Development Services Department.

Sustainability Guidelines

- 32-4 The use of pervious paving and bio-swales is encouraged to reduce stormwater runoff.
- 32-5 Light colored paving materials are preferred for primary paving materials to reduce heat transmission. Darker colors may be used in small amounts to add visual interest.

33 Services and Utilities

Design Principle

Accessory structures, such as mailboxes and laundry rooms, should be easily accessible to residents. Service elements, such as trash enclosures and mechanical equipment, should be screened from view.

Rationale

Common facilities, such as mail areas, laundry rooms, swimming pools, and playgrounds, should be easy for residents to find and use. Trash receptacles and utility boxes should be equally accessible but screened from public view to protect the visual quality of the development.

Design Guidelines

Trash and Recycling Enclosures

- 33-1 Trash and recycling receptacles should be screened from view. Landscaping around trash enclosures will help to soften and screen what may otherwise be an unattractive structure.
- 33-2 Curbs and other impediments should be avoided so that receptacles are easily accessible for trash removal.
- 33-3 Trash/recycling enclosures must be made of a durable material, such as brick, concrete, or stucco, and should complement the design of the primary structures.
- 33-4 Trash/recycling enclosures should be located so that noise and odors are not detectable by nearby residents.

Storage Areas

- 33-5 Storage for personal items should be provided in structures that match the design and materials of the primary buildings.
- 33-6 Storage areas should be located so that residents can easily access them from parking areas.

Utilities, Mechanical, Heating, Ventalating, and Air Conditioning

- 33-7 All utilities, including radio and cable lines, should be installed underground. The visibility of roof-mounted satellite dishes should be minimized.
- 33-8 Mechanical equipment should be included in the design of the building where possible. If this is not feasible, it should be screened with a solid enclosure and landscaping.
- 33-9 Exterior utility equipment should be placed in low-traffic areas and screened by landscaping.
- 33-10 Where feasible, heating, ventilation, and air conditioning units should be placed on the north side of buildings (if not the street side) to shade the units and minimize energy consumption.



Attractive and accessible mailbox facility



Appropriate screening of HVAC unit behind fence

This Page Intentionally Left Blank

Manufactured Homes

Manufactured homes are defined as structures that are:

transportable in one or more sections, which, in the traveling mode, is 8 body feet or more in width, or 40 body feet or more in length, or, when erected on site, is 320 or more square feet (U.S. Department of Housing and Urban Development 1974).

Unlike single-family homes that are built on-site, and are regulated by construction standards established by various national engineering and manufacturing boards, manufactured homes are regulated by the U.S. Department of Housing and Urban Development (HUD). HUD has established two key regulatory codes:

National Manufactured Home Construction and Safety Standards Act of 1974 (1974 Act)
Manufactured Housing Improvement Act of 2000 (2000 Act)

Both laws set national standards for construction, safety, and energy conservation during the factory production process. The 2000 Act also provides for a private sector consensus committee to make recommendations every two years on new innovations in manufactured home design.

In addition to these national laws, the State of California also regulates manufactured housing through its Mobile Homes–Manufactured Housing Act of 1980, which is primarily concerned with the proper installation of manufactured homes in mobile home parks.

Local jurisdictions may supplement the manufacturing and installation standards set by HUD and the State of California with standards that regulate the appearance and exterior amenities of manufactured homes.



Contemporary manufactured homes must include attractive architectural detailing.

Photo Courtesy of California Institute of Manufactured Homes

Manufactured Homes

Although manufactured homes are still fairly uncommon as infill development, they are appealing to some because they are less expensive than site-built homes. Like other forms of infill construction, however, manufactured homes must fit within the overall neighborhood context.

Manufactured homes are no longer simply long, narrow metal boxes. Instead, they can be constructed with gabled, tilt-up roofs, porches, built-in garages, and the types of siding and roofing that would be found on a typical site-built home. These Design Guidelines provide recommendations for the type of exterior improvements that should be made to manufactured homes to ensure that they complement existing site-built homes.

SITE DESIGN

34 Setbacks, Garages, and Parking

Design Principle

The manufactured home should reflect the architectural style and setbacks, as well as the orientation of structures and their entries of established single-family homes on the block.

Rationale

Manufactured homes are traditionally linear in design and construction, with a front entry on the long side of the home. This poses a challenge when placing them on the long, narrow lots often found in some Del Paso Heights neighborhoods, as the “front” entry of older manufactured homes could open onto the side yard.

Newer manufactured homes are more flexible in design and construction, and can be selected to better fit into the context of single-family neighborhoods. Developers and homeowners contemplating the purchase of a manufactured home should select models and options that reflect the basic design of the single-family homes on the block where the manufactured home will be installed.

Design Guidelines

Lot Orientation and Setbacks

34-1 Setbacks and site planning should follow the same standards as site-built housing, as described in the “Single-Family Residential” section of the Design Guidelines, with the main entry on the street side.

Garages and Carports

34-2 Garages and carports provided for manufactured housing should follow the same design guidelines as for site-built residential housing. Where possible, the garage should be integrated into the manufactured home design as an enclosed garage.

Parking

34-3 Parking provided for manufactured homes should follow the same design guidelines as for site-built residential housing.

Manufactured Homes

ARCHITECTURAL ELEMENTS

35 Creating an Attractive Streetside Facade

Design Principle

The manufactured home should be selected to create an inviting front side that faces the street.

Rationale

Manufactured homes should be designed to provide an inviting facade on the street side that includes a door, windows, and a porch. Construction of tilt-up roofing in manufactured homes allows control over the roof pitch, which can be tailored to the neighborhood.

Design Guidelines

- 35-1 All manufactured homes should have a door that faces the street side. The entry feature should be embellished with a porch or stoop in a style similar to other homes with porches on the block.
- 35-2 The street side should have at least one window from a major interior living area (not a bathroom window).

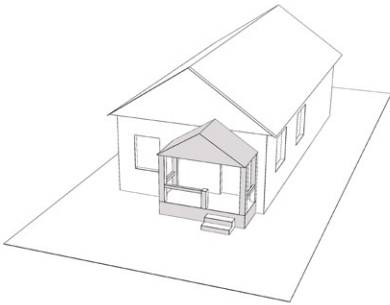

Manufactured homes must be constructed with a front porch or stoop.

36 Applying Site-Built Home Standards to Roof Design

Design Principle

The pitch and style of the roof should not be flat, but should be consistent with the roof pitches and styles of the established neighborhood context.

Rationale

The flat roof of older manufactured homes can be avoided. Newer models offer gable roofs with a roof pitch similar to those found in site-built homes.

Design Guidelines

- 36-1 The roof pitch should be consistent with the neighborhood context, and have a minimum rise of 5 inches for 12 inches of horizontal run.
- 36-2 The roof should include eaves that project and have a minimum overhang of 12 inches, including 4 inches for gutters.



The roofline and materials of contemporary manufactured homes must be identical to site-built homes.

Photo Courtesy of Federal Trade Commission

Manufactured Homes



This manufactured home has been constructed with brick over the foundation and a front porch to give the appearance of permanency.

37 Giving an Appearance of Permanency

Design Principle

The manufactured home should be installed on the site so as to give the appearance of a permanent home.

Rationale

In addition to removing any running gear, the manufactured home should be installed with the same level of permanency as a single-family home.

Design Guidelines

- 37-1 Any running gear, tongue, axles, and wheels should be removed at the time of installation.
- 37-2 The home should be installed on a permanent concrete or masonry and concrete foundation.
- 37-3 Siding, brick facing, or other high-quality exterior treatment should be used to fully cover the wheels and any gap beneath the bottom of the home. This exterior treatment should extend above the finished floor level of the home and be coordinated with the overall siding used on the home.

38 Selecting Suitable Materials

Design Principle

The materials used on the manufactured home should be consistent with the materials found on site-built, single-family homes in the neighborhood.

Rationale

Every effort should be made to ensure that the materials used on the manufactured home are indistinguishable from those used on other homes in the neighborhood.

Design Guidelines

- 38-1 The siding used on the manufactured home should be consistent with siding on other homes on the block.
- 38-2 Brick or stone wainscoting are recommended where appropriate.
- 38-3 The roof should be surfaced with a material of one of the same types recommended for site-built homes, including composition, tile, or cement fiber shingles.

This Page Intentionally Left Blank

Commercial Design Guidelines



Commercial Design Guidelines

The commercial areas in Del Paso Heights display varied urban design patterns and architectural styles that reflect their unique historical influences. Despite the range of historical periods and architectural variety, the neighborhood's commercial streets will benefit from design guidelines that strengthen their walkability and visual appeal, as defined in these Design Guidelines.



New commercial development on Marysville Boulevard should be designed to encourage pedestrian activity adjacent to the street with site furniture, shade trees, and other amenities.

Introduction

COMMERCIAL HISTORY AND NEIGHBORHOOD CONTEXT

This section outlines the relevant history of commercial areas in Del Paso Heights, with an emphasis on architectural styles, construction materials, and notable buildings found on primary commercial streets. The architectural styles mentioned in this section are described in greater detail in Appendix C, “Predominant Commercial Architectural Style,” at the end of this document.

Del Paso Heights is predominantly residential, with commercial development concentrated on Marysville Boulevard. In addition, some limited commercial, civic, and office professional businesses are located at the intersection of Grand Avenue and Rio Linda Boulevard. The majority of the commercial development in these two areas was constructed in the latter half of the twentieth century, with recent commercial infill and renovations of existing buildings along Marysville Boulevard area.

In addition, a commercial district has been identified for the intersection of Norwood Avenue and Silver Eagle Road as part of the Del Paso Nuevo Special Planning District. Although this commercial district has not been constructed by the completion of these Design Guidelines, its design has been detailed in the Special Planning District Development Guidelines for Del Paso Nuevo.

Marysville Boulevard has been identified by the City of Sacramento as a Targeted Neighborhood Commercial Corridor (TNCC), and as such, is subject to more intensive City investment. Both Redevelopment Agency and City efforts have been focused on and in the vicinity of the intersection of Marysville Boulevard and Grand Avenue. Recent improvements include the construction of the Greater Sacramento Urban League building, streetscape improvements under the Marysville Boulevard Urban Design Plan, and significant upgrades to water and sewer infrastructure. The intersection of Marysville Boulevard and Grand Avenue is slated to become the core commercial district with pedestrian-scaled development.

Grant Union High School is the local civic landmark and the heart of the neighborhood. Its striking California Mission Revival architecture has served as the inspiration for other commercial and civic structures, including the William J. Kinney Police Substation on Marysville Boulevard. The *Marysville Boulevard Urban Design Plan* encourages new development to incorporate Mission style design elements. These Design Guidelines should be viewed as complementary to the Urban Design Plan.



William J. Kinney Police substation on Marysville Boulevard



Greater Sacramento Urban League on Marysville Boulevard

SITE DESIGN

This section provides direction for the site design of new commercial development and the renovation of existing structures. Effective site planning techniques should create a unified commercial environment that reflects the character and history of the area.

The major principles of commercial site design are intended to:

- create a comfortable and welcoming pedestrian environment;
- enhance the vitality of the commercial district;
- create a distinctive character and sense of place for commercial streets; and
- clearly define the public realm with a “streetwall” of commercial buildings that frame the street.



A pedestrian-oriented commercial district can include street trees, cafe seating, and wide sidewalks.



This commercial district has a traditionally designed “streetwall” of buildings.

Commercial

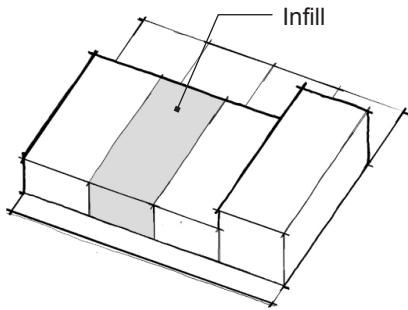

New construction and additions should be built to the back of the sidewalk or at the front of the property line.

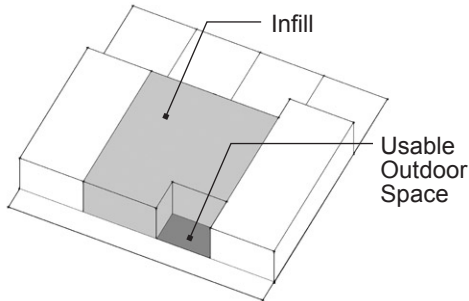

New construction and additions may increase a portion of the front setback if designed as usable outdoor space.



A traditional commercial district has buildings built to the property line.

39 Building Orientation, Setbacks, and Build-To Lines

Design Principle

Buildings should be constructed to the front of the property line behind the sidewalk, with allowable variation in the setback to provide for café seating, plazas, and other additions to the public realm.

Rationale

Commercial buildings in urban areas have typically been built to the front of the property line behind the sidewalk, creating a line of buildings with a consistent “streetwall” that supports a strong relationship between the building, the sidewalk, and the street. This streetwall should be reinforced by new construction and additions. The streetwall may be varied to create usable public spaces such as outdoor café dining and small plazas with seating.

Design Guidelines

- 39-1 Buildings should be constructed to the front of the property line and from side property line to side property line.
- 39-2 Many existing commercial structures in Del Paso Heights have parking in lots at the front of the buildings. To create a more pedestrian-oriented commercial district, new commercial construction on Marysville Boulevard should *not* follow the established context, but should place buildings at the front of the lot line near the sidewalk, with parking lots located at the rear of buildings.
- 39-3 Facades that front onto a public street should be built parallel or nearly parallel to the public right-of-way.
- 39-4 A portion of the front setback may be increased by as much as 15 feet, if that setback is used as public space, such as outdoor restaurant seating or a courtyard with public access. A minimum of 60% of the front facade should be constructed up to the front setback.
- 39-5 Buildings at corners may be set back to create corner entries or “chamfered” entries.
- 39-6 New buildings should provide an appropriate setback to allow rear- and side-yard facing windows on existing buildings to have access to light, air, and usable space between buildings.

40 Parking

Design Principle

Parking areas should provide vehicular access without compromising pedestrian accessibility and the character of the public realm on primary commercial streets. Parking lots should be placed at the rear of the building, when feasible, to not obstruct views of the building's front facade from the street.

Rationale

Adequate and accessible parking areas are important to the viability of commercial districts. However, large surface parking lots fronting the street can create the appearance of a vacant and uninviting area that detracts from the visual continuity of the commercial streetwall and impedes and discourages pedestrian traffic. Smaller parking lots located at the rear or sides of commercial buildings are a recommended alternative.

Design Guidelines

- 40-1 Parking lots should be located behind the commercial frontage on major pedestrian streets. Where parking at the rear of the building is not possible, it may be located in an interior side lot. Parking at the front of the building or corner lots is highly discouraged.
- 40-2 Driveways into parking lots should be located on side streets, where feasible. Access to parking on major pedestrian streets should be minimized.
- 40-3 Parking lots should include signage and well-designed locations for ingress and egress that reduce conflicts with pedestrian movement.
- 40-4 Access to commercial buildings from rear or side parking lots or alleys should be well maintained and kept clear of obstructions.
- 40-5 Parking structures that are located on primary commercial streets should be designed with retail, office, or other uses at the street level to avoid monotonous blank walls.
- 40-6 Parking structures should be designed with architectural features that complement existing commercial, office, and mixed use buildings in the vicinity.
- 40-7 Parking structures should be designed to incorporate passive safety design features to create a secure facility. The use of glass for pedestrian stairways and adequate interior lighting are encouraged.
- 40-8 Parking structure entry/exit ramps should be mid-block or toward service areas rather than facing pedestrian streets.

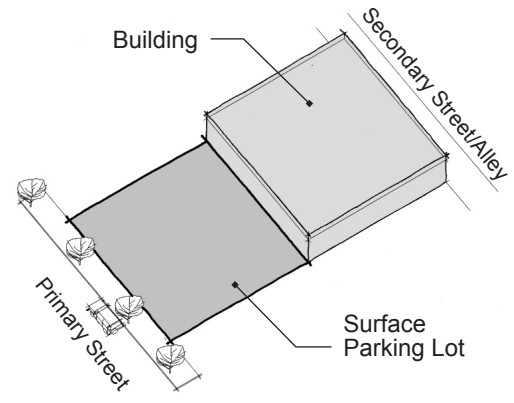

Avoid placing parking at the front of the building.

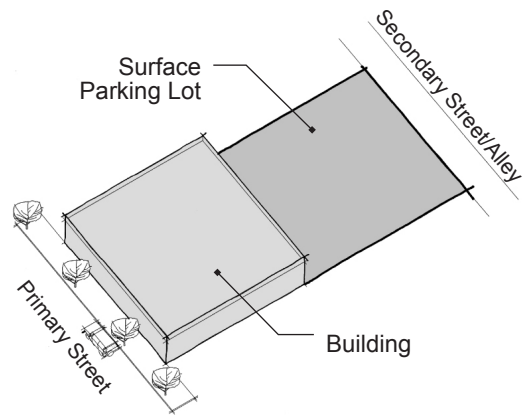

Parking should be unobtrusive to encourage an active street life and a comfortable pedestrian environment. Parking should be placed behind, under, or on the side of buildings.



The facade of this parking structure has been designed to complement the adjoining commercial building.

Commercial

ARCHITECTURAL ELEMENTS

Architectural design guidelines address the exterior of buildings, as well as the relationship of these buildings to the surrounding built context. It is paramount to ensure that the design of the building complements the community setting and character and contributes to the public realm. Architectural design should promote commercial buildings that are:

- visually welcoming from the primary pedestrian street;
- similar in mass and scale to other commercial buildings in the area; and
- constructed of high-quality materials that will contribute to the longevity of the building.



Human-scaled design can contribute to a pedestrian-friendly commercial district.

41 Building Height, Massing, and Scale

Design Principle

The size and scale of commercial buildings should be compatible with existing development in commercial districts.

Rationale

To ensure compatibility with existing development, new development should appear similar in massing and scale, and the heights of new buildings should generally fall within the height range of existing buildings on the block.

Design Guidelines

- 41-1 New, higher buildings can reinforce the established building heights along a block by stepping back upper floors that are above the average building height along the street.
- 41-2 A building that is larger than the average of buildings on the same block should break up the mass of the structure with articulation of the structure into smaller components, and the creation of multiple surfaces.
- 41-3 Appropriately scaled doors, windows, awnings, and detailing, particularly at the ground floor level, can reduce the appearance of mass.
- 41-4 Buildings on corner lots provide an opportunity for structures that exceed the average height on the block and can serve as anchor points.
- 41-5 Building heights should not block important view corridors in the neighborhood.

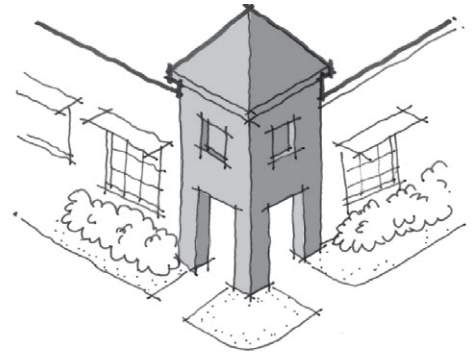

Buildings at corners can exceed the average height and anchor the block.

Sustainability Guidelines

- 41-6 Massing design should provide opportunities for daylighting and solar panels. Glazing should be located predominantly on the north and south sides of the structure, with glazing on the west side of the structure minimized unless the west side is the street side.



Infill construction and additions that deviate from the typical proportions of height, width, and depth may appear out of scale with existing buildings.



Infill construction and additions should respect the typical proportions of height, width, and depth.

Commercial

42 Building Facades

Design Principle

Building facades should be designed to create visually interesting buildings that offer variety along the commercial street.

Rationale

Building facades provide the interface between the built environment and the public realm. Historically, commercial districts have consisted of buildings that are one or two stories in height and cover entire lots. This pattern creates a regular rhythm of building mass and streetwalls. A streetwall of varied building facades is visually appealing and enhances the pedestrian environment. Blank walls at the ground floor level are unattractive and uninviting and should be avoided. Instead, elements should be used to create visual interest, including awnings and canopies, trellises, detailed parapets, or arcades.

In recent decades, new buildings have increased in size and scale, creating greater challenges to creating human-scaled commercial environments. Therefore, appropriate architectural elements, such as window openings, commercial displays, frequent building entries, ornamentation, windows, doors, awnings and canopies, contribute to a pleasant urban streetscape.



Avoid expansive blank walls along streets.

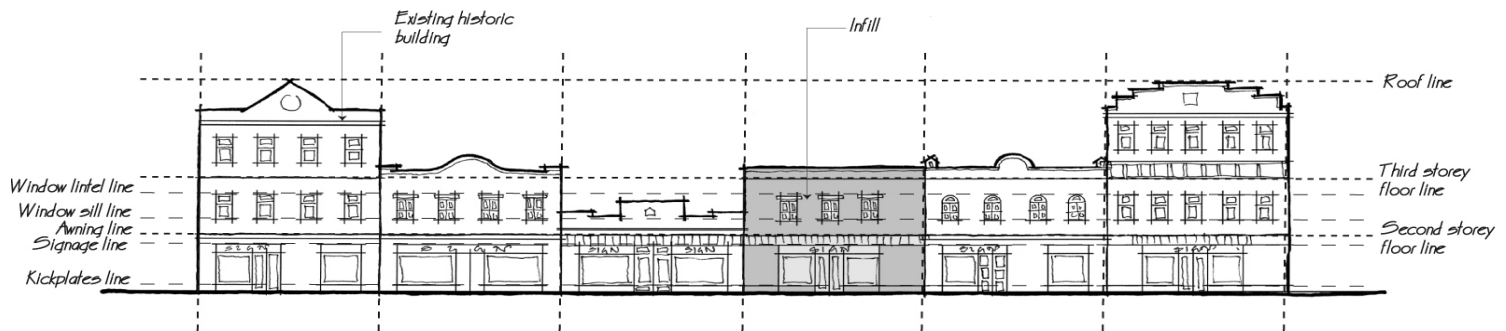

New construction, additions, and alterations should draw from existing architectural features.

Design Guidelines

- 42-1 Doors, windows, floor heights, cornice lines, signage, and awnings should be appropriately scaled to reduce the mass of buildings as they are experienced at the street level.
- 42-2 The primary facade of a building must face a public street and include entries that are accessible from the street, where feasible.
- 42-3 The main entrance of a building without street edge facades should open directly onto a publicly accessible walkway. This walkway should connect directly to an adjacent street sidewalk.
- 42-4 Building facades facing streets should be lined with windows, entries, and openings that provide indoor and outdoor views to the public rights-of-way and sidewalks. Continuous blank wall surfaces are not allowed.
- 42-5 Architectural features, such as display windows, pilasters, lattices, and alcoves for the display of products, can provide visual relief on buildings that cannot achieve continuous openings along the street and sidewalk.
- 42-6 Facades can also be articulated with insets, partial setbacks, and small pedestrian plazas (see Section 39, “Building Orientation, Setbacks, and Build-to Lines”).



This building is a contemporary interpretation of traditional design.

Commercial

- 42-7 Solid roll-down security grates should not be used on the exterior of the building; however, they may be placed on the interior of storefront glazing or entry doors.
- 42-8 Highly reflective or dark tinted glass should be avoided.
- 42-9 Building facades should be designed to create a recognizable “base” and “top.” Building bases and tops can be created with variations in:
- building wall thickness;
 - use of special materials;
 - changes in colors and materials on window trim;
 - cornice treatments;
 - roof overhangs with brackets; and
 - use of ornamental building lines.
- 42-10 The Marysville Boulevard Urban Design Plan encourages new development to incorporate Mission style design elements. Under the Commercial Design Guidelines, new development should also offer creative and original interpretations of the Mission architectural style, with unique form and color to promote a varied and interesting streetscape.



New construction and additions are encouraged to use horizontal elements to create a “top” and “base” that give definition to the building and break down the facade into elements that can be comprehended by pedestrians at the street level.

Commercial

42-11 Mixed-use development combines commercial development with other uses, such as office and residential. When mixed-use development is vertical in form, the commercial and office professional uses should be on the first story, with residential above. The first story should be designed as described in Guideline 42-4, with a large percentage of windows, doors, and other transparent surfaces. Upper stories should have a larger percentage of opaque surface, which can be articulated with windows, balconies, and patios.



Mixed-use building with ground floor retail and residential above, Orenco Station, Oregon



This mixed use building has a strong corner treatment, a clearly defined base, and an articulated facade.

Commercial

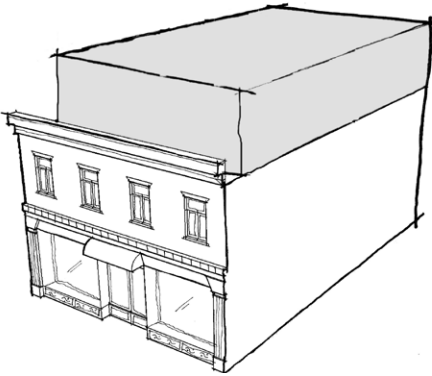

Addition to the top of the structure, with a second-story setback from the existing facade

43 Additions

Design Principle

Additions should be consistent with and not disrupt the architectural style, massing, proportions, and scale of the existing building.

Rationale

Additions should be designed as an adjunct that does not visually interfere with the original structure. The architectural details on the addition should be designed to reflect those on the original building.

Design Guidelines

- 43-1 An addition should respect, but be subordinate to, the design of the original building, and should be designed so that the form of the original structure can still be recognized.
- 43-2 An addition should not alter or destroy the architecturally defining features of the building, such as original porches, columns, railings, stairs, windows, doors, and roof and eave forms.
- 43-3 A large addition should be broken down into smaller, varied components that relate to the scale and massing of the original structure.
- 43-4 An addition should be compatible with the overall character of the property, block, and neighborhood.
- 43-5 An addition should be set back from the primary facade, especially if the additions are taller than the original building.

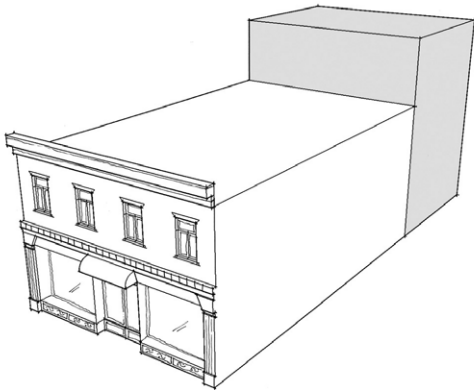

Addition at the rear of the original structure

44 Roof Forms

Design Principle

The roof forms of new development should reflect the rooflines of established commercial structures.

Rationale

Flat rooflines are typical of much established commercial development. New commercial development should try to emulate this existing form to maintain the character of the neighborhood. However, variation in roof shapes can be desirable if compatible with existing buildings on the block.

Design Guidelines

- 44-1 Articulated facade surfaces with multiple rooflines are encouraged for taller buildings to avoid an appearance of mass and to add interest.
- 44-2 Roof parapets may be used to add visual interest to flat roof lines.
- 44-3 One-story buildings should avoid the use of exaggerated, sloped roof forms.
- 44-4 Special roof forms on corner buildings are encouraged to help accentuate the corner location.

Sustainability Guidelines

- 44-5 The addition of photovoltaic solar panels is encouraged to reduce energy use.
- 44-6 The use of “cool roof” materials and or “green” roofs is encouraged to reduce energy use, heat transmission, and stormwater runoff and improve the water quality of stormwater runoff.
- 44-7 Roofing options that include recycled content are encouraged.

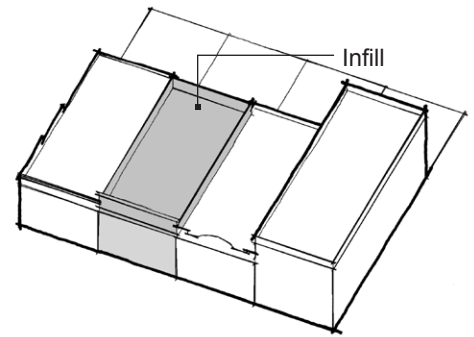

Infill project with a flat roof similar to other nearby existing structures.

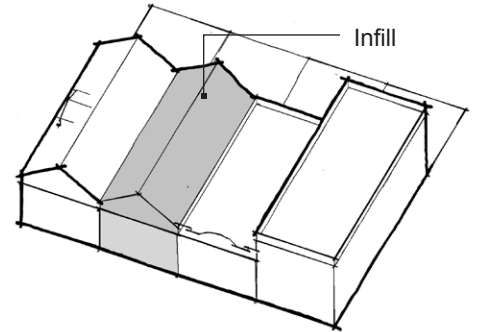

An infill project with a pitched roof in areas where nearby buildings have pitched roofs is acceptable.



Typical flat commercial roof

Commercial



A contemporary recessed entry



Even simple entries can be embellished with architectural detailing to improve their appearance. This building has decorative painted trim.

45 Entry Features

Design Principle

Entry features of commercial buildings should be clearly visible to pedestrians, with a defined relationship to the street and sidewalk.

Rationale

A recessed entry helps to break up the massing of a building and make the threshold immediately apparent to pedestrians. Decorative features, such as awnings, canopies, lighting, and signage, can also be used to clearly define and articulate an entryway.

Design Guidelines

- 45-1 Primary entries should be located on major sidewalks to provide clearly visible pedestrian access.
- 45-2 The size of the entry should be proportional to the building.
- 45-3 Secondary entries may be located at the side or rear of the building to provide access from parking areas.
- 45-4 Entries should be clearly defined with signage and architectural details.
- 45-5 In mixed-use buildings, the entrance to residential uses on the second story should be clearly defined and easily approachable from a public street or sidewalk.

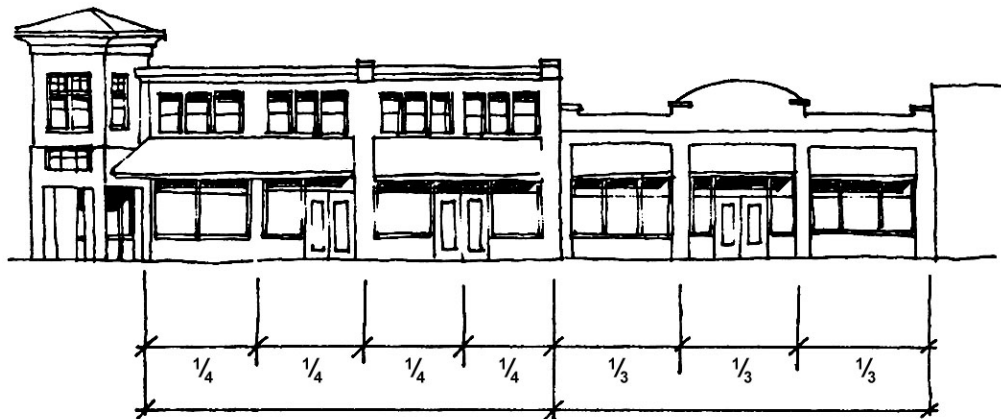

Building openings should maintain the proportions and spacing of other openings on the block

46 Windows and Doors

Design Principle

The proper placement and design of windows and doors should be used to create visual interest in commercial buildings and contribute to the stylistic coherence of development along the street.

Rationale

The proper placement of windows and doors along a street frontage is one of the best methods of creating visual interest and reducing the appearance of mass. Storefront windows at the street level can be used to allow pedestrians to see into the structure, and individuals inside the building to view the street, improving visual surveillance of the area outside the building and increasing security.

Design Guidelines

- 46-1 Windows, entries, and doors should occupy most of the wall surface on the ground floor.
- 46-2 Building openings, such as windows and doors, should maintain the proportions and spacing of other openings on the block.
- 46-3 Headers, trim, and sills of windows of new buildings should be well articulated in design, dimensions, and profiles.
- 46-4 Windows should be made of clear glass to allow pedestrians to see into the structure. Use of mirrored or dark tinted glass is not allowed.
- 46-5 Windows with authentic mullions that contain true divided lights are encouraged.
- 46-6 Doors should primarily be constructed of transparent materials, such as panels with glass, full-light glass, or glass panes in a wood or metal frame.
- 46-7 Security bars on the outside of commercial windows are highly discouraged.

Sustainability Guidelines

- 46-8 Skylights are encouraged to daylight the interior floor area, thus reducing energy use and creating a more pleasant retail/commercial environment.
- 46-9 Prismatic glazing is encouraged to increase the energy efficiency of skylights.
- 46-10 Windows should be oriented to maximize controlled daylighting from the south and north.
- 46-11 The use of insulating glazing such as LoE² is encouraged to increase energy efficiency.



A commercial facade lined with transparent glass is highly desirable.



Commercial doors should primarily be constructed of transparent glass.

47 Color

Design Principle

Color should be used in a way that complements the surrounding structures and adds to the liveliness and character of commercial districts.

Rationale

The use of pre-approved colors can lead to a repetitive streetscape that is lacking in distinction and interest. Matching existing color schemes can also lead to blocks, or an entire district, in one repetitive color. In general, the major design principle in the selection of building colors is to be compatible with, but not identical to, surrounding development.

Design Guidelines

- 47-1 Colors should be compatible with those of the neighboring buildings.
- 47-2 Creative use of colors is encouraged. Unique or unusual color schemes will be considered on a case-by-case basis during the design review process.
- 47-3 Building colors that complement natural materials, such as brick, stone, tile, and terra cotta, are encouraged as a primary building color. Building colors should avoid more intense colors as a primary design element.
- 47-4 Contrasting accent colors are encouraged for architectural details, awnings, and entrances.
- 47-5 Colors should be selected with consideration for the orientation of buildings. Colors on south- and west-facing facades will often appear warmer, due to sun exposure, than the same colors on the north or east sides.
- 47-6 Fluorescent, neon, or “dayglo” colors are strongly discouraged as the primary color.

48 Materials

Design Principle

Buildings should be constructed of high-quality materials that will promote the longevity of the structure and provide a pleasing appearance as the materials age.

Rationale

High-quality finish materials promote the longevity of a building and add to its character, particularly on the ground floor, where people are most likely to come in contact with the building and can easily see and touch the materials.

Design Guidelines

- 48-1 Use of materials commonly found in other commercial buildings on the street is recommended.
- 48-2 Durable, solid facing materials should be used.
- 48-3 Use of the following materials is not allowed:
 - vinyl or grooved plywood siding
 - sprayed-on, textured stucco
 - raw, raised grain, or rough-sawn wood
- 48-4 Materials commonly found in Del Paso Heights include brick, stucco, and ceramic tile, and their continued use in new construction is recommended.
- 48-5 Wood should be milled, with a smooth, painted finish.

Sustainability Guidelines

- 48-6 The use of materials that include recycled content is encouraged to reduce waste.



Stucco



Stucco, tile, and glass block



Brick of varied textures and patterns



Ceramic tile



Brick of varied textures and patterns

Commercial



Canvas awning

49 Canopies, Awnings, and Arcades

Design Principle

When incorporated into a commercial building, canopies, awnings, and arcades should be made of high-quality components that complement the overall design, colors, and materials of the building.

Rationale

Canopies, awnings, arcades, and overhangs are traditional commercial design elements that articulate the building facade and create variety and interest at the street level. They also serve the practical purposes of providing space for signage of commercial uses, shading windows during the summer to reduce energy use, and providing shade and weather protection for pedestrians, encouraging walking instead of auto use.

Design Guidelines

- 49-1 Canopies, awnings, arcades, and overhangs are encouraged over window displays and entries along public sidewalks on the ground floor of commercial buildings.
- 49-2 Canopies, awnings, and overhangs that project into the public right-of-way are subject to a City revocable encroachment permit. Contact the Building Division of the City Development Services Department for more information.
- 49-3 Canopies, awnings, and arcades should be designed with respect for the proportions of the building in terms of size, shape, and placement unless a unique architectural style encourages something different.
- 49-4 Canopies and awnings should fit within individual bays or structural divisions of the building facade rather than extending beyond a single bay, unless the building structure dictates an alternative placement.



Steel overhangs help to articulate commercial entries, offer shade, and add architectural interest to the building.

Commercial

- 49-5 Use of a continuous awning for the windows in the upper floors is discouraged. Each window should be articulated with an individual canopy or awning, with awnings extending no more than halfway down the window. The color and style should complement ground-level awnings and canopies on the same building.
- 49-6 Self-supporting canopies and awnings are recommended.
- 49-7 A variety of solid and striped colored awnings may be considered.
- 49-8 Brightly colored awnings should be compatible with the colors used on the main building. Uncolored or light-colored canvas awnings may be appropriate for dark and north-facing facades to allow daylight to filter through to storefronts and second-story windows.
- 49-9 Canvas, fire-resistant acrylic, and metal are preferred materials for awnings. Vinyl, plastic, plasticized fabric, and fiberglass awnings are strongly discouraged.
- 49-10 Canvas awnings often fade and deteriorate over time. Canvas awnings will need regular maintenance and periodic replacement.
- 49-11 Awnings, decorative roofs, and miscellaneous entry features may project into the front public right-of-way, provided that they are not less than 8 feet above the sidewalk.
- 49-12 Canopies and awnings should only be internally illuminated where appropriate to the architectural style of the building.
- 49-13 Canopies and awnings should be designed to provide window shading to reduce energy use.

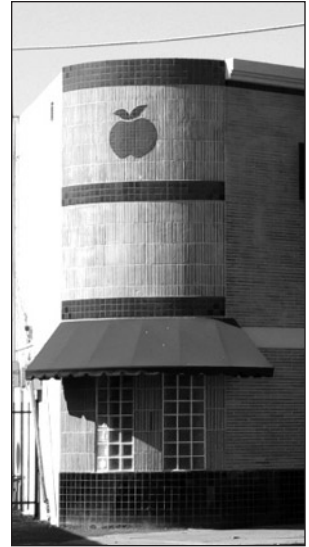

A corner awning



Steel awnings



Commercial



Signage applied to a glass window



Wall-mounted, projecting "blade" signage

50 Signage and Graphics

Design Principle

Building identification signs and graphics should enhance the appearance of the building and contribute to the overall character of the street, while minimizing the appearance of clutter.

Rationale

Attractive, artistic, well-proportioned, and carefully located signs can enhance the character of commercial districts. Signage should be used for information, direction, and wayfinding, and not for advertising specific products. Signage should enhance the character of existing older buildings, and can help new development to be compatible with existing development.

Design Guidelines

- 50-1 All commercial signage is subject to a City of Sacramento sign permit. Contact the Building Permits Division of the Development Services Department for more information.
- 50-2 Signage can be wall-mounted, projecting, combined with awnings, or placed on windows. Hanging signs with projecting lettering are encouraged.
- 50-3 Cabinet and pole signage are discouraged.

Commercial

- 50-4 Materials and colors of signage must be compatible with those of the building as well as adjoining buildings.
- 50-5 Signage should be modest in scale and appearance, and should complement, not overpower, the building.
- 50-6 Signage should not obscure important architectural elements, such as windows, cornices, or decorative details.
- 50-7 Individual shop signs in a single storefront should relate to each other in design, size, color, lettering style, and placement on the building.
- 50-8 Buildings with multiple tenants should have a common signage program and include a multiple directory.



Signage for multiple tenants



Signage printed on an awning

Commercial

51 Lighting

Design Principle

Lighting fixtures should be designed to complement and enhance the architectural style of the building and should be compatible with the character of the area.

Rationale

Lighting on buildings and sites can have a dramatic effect on the mood, quality, and character of commercial districts. The color, intensity, and types of lighting used in streets, on buildings, and in landscaping contributes to the character of commercial areas.

Adequate and carefully placed lighting can improve the safety and security of a site, adjacent streets, and surrounding properties. Visibility at intersections and pedestrian crossings can also be enhanced with appropriate lighting.

Design Guidelines

51-1 Building lighting should relate to the style and character of lighting on the whole site.



Pedestrian pole lighting with a solid top eliminates light spillover and glare.



Pedestrian-scaled bollard lighting

Commercial

- 51-2 Use of neon, marquee lighting, and other specialized lighting is appropriate in some areas, and may be used for restaurants and entertainment uses.
- 51-3 Pedestrian areas should be lighted by pole- or bollard-type fixtures that are not more than 14 feet in height for pole lighting, or 3 feet in height for bollards.
- 51-4 Specialized lighting is appropriate for building features, entries, building towers, and other architectural elements.
- 51-5 Lighting should provide even illumination. Flashing, pulsating, rotating, or otherwise moving light fixtures are not appropriate.
- 51-6 Lighting fixtures must not obscure major architectural features.
- 51-7 Lighting should not direct unwanted glare toward adjacent residential or other sensitive areas. Downlighting and specialized fixtures that reduce sky-lighting and glare are encouraged.

Sustainability Guidelines

- 51-8 Compact fluorescent bulbs and photocell sensors are encouraged to achieve energy efficiency.



Contemporary lighting



Gooseneck Lighting

Commercial

52 Service Areas and Utilities

Design Principle

Service and utility areas, including loading docks, storage areas, mechanical systems, and trash bins, should be screened from view and integrated into the design of the project.

Rationale

Although necessary and functional aspects of commercial districts, service areas, loading docks, delivery areas, and mechanical equipment can be unsightly and noisy and may detract from the quality of the urban environment. Functional service areas of buildings should receive the same design attention and consideration as more public spaces and should be carefully placed and screened to reduce noise and visual blight.

Design Guidelines

Service Areas and Loading Areas

- 52-1 Service areas, including loading docks, storage areas, and trash bins, should be screened from adjoining walkways.
- 52-2 To the extent feasible, loading areas should be located and designed to minimize their visibility from public areas and adjacent properties. Loading areas should be accessible from side streets, interior parking garages, or the rear of buildings rather than from the fronts of buildings.
- 52-3 Landscaping and decorative walls and fences should be used to screen mechanical equipment, loading areas, and other service areas.
- 52-4 Where feasible, loading areas should be functionally separated from parking and pedestrian walkways for safety and to provide convenient access for delivery trucks.



The rear of this commercial building has been carefully screened.

Mechanical Systems

- 52-5 Mechanical equipment, such as air conditioning units, pipes, ducts, vents, access doors, meters, transformers, and other building systems equipment that produce noise, exhaust, or visual unsightliness, should be located away from pedestrian ways.
- 52-6 All such equipment should be screened or hidden from public view in a manner consistent with the character of the building and the surrounding district.
- 52-7 Rooftop and ground mounted mechanical equipment and trash storage areas should be screened from view from adjoining properties and public rights-of-way.

Trash Enclosures

- 52-8 All outdoor trash and garbage containers should be located at the rear of lots away from public view and screened with solid, decorative walls that match the design of the primary structure. Where possible, trash enclosures should not be located along the pedestrian ways and streets.

Sustainability Guidelines

- 52-9 Where feasible, heating, ventilation, and air conditioning units should be placed on the north side of the building (if not the street side) to shade the units and minimize energy consumption.

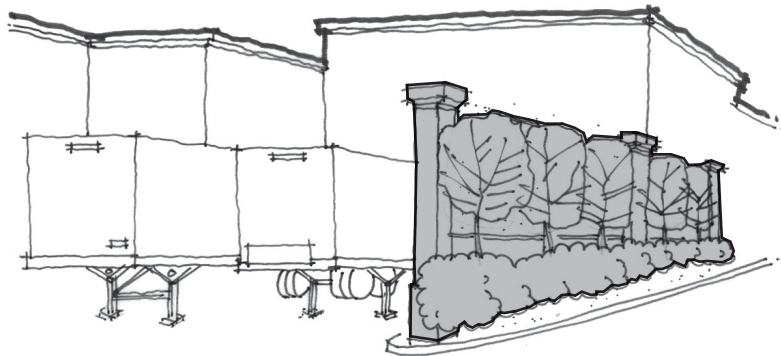

Service/loading and trash areas should be screened from view with landscaping, walls, or other structures.

Commercial

STREETSCAPE GUIDELINES

The design of the streetscape should address the relationship between commercial buildings and the public realm by providing such amenities as street trees, street furniture, landscaping, and paving. A successful streetscape should foster a sense of place and feelings of community pride and ownership. It can also enhance the value of commercial properties. Elements such as street trees and street furniture should contribute to a walkable, pedestrian-scaled environment. The streetscape design in the neighborhood should also support public social interaction and enhance the vitality of the commercial district. The *Marysville Boulevard Urban Design Plan* provides additional guidance for streetscape improvements on Marysville Boulevard.



Streetscapes that include landscaping, lighting, and street furniture help to create an inviting commercial district.

53 Parking Lot Design

Design Principle

Parking lots should be screened from the street and nearby sidewalks and provide shade to parked automobiles.

Rationale

Parking lots should be adequately screened with fences, walls, and landscaping. Trees and landscaped areas incorporated into parking lots can help to soften paved areas, reduce heat during the summer months by providing shade, and filter pollutants from the air.

Design Guidelines

- 53-1 Surface parking lots adjacent to public sidewalks should be screened with appropriate design elements, such as fences, walls, and landscaping.
- 53-2 Screening materials should not block views of the parking lot from passing cars to promote visual surveillance of the lot.
- 53-3 Use of a trellis-style structure attached above a wall or fence can help maintain the character of the streetwall and improve the pedestrian environment along the street.
- 53-4 Parking lots shall be planted with trees to provide a minimum of 50% shading after 15 years in conformance with City Municipal Code Section 17.68, "Landscaping and Paving Regulations." Shading should be calculated by using the expected diameter of the tree at 15 years. A link to the City of Sacramento Parking Lot Tree Shading Design and Maintenance Guidelines is available at:
cityofsacramento.org/parksandrecreation/urbanforest/#right

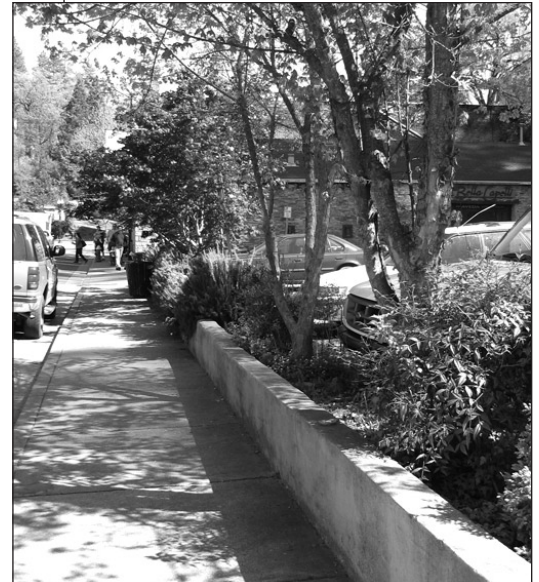

Landscaping should screen parking lots from the street while still allowing some visibility to promote safety.



This landscaped walkway allows pedestrian access to local businesses.

Commercial



Alternative surfaces such as grass pavers keep stormwater runoff on-site and reduce heat production.



Modular pavers are another attractive alternative that helps to keep stormwater runoff onsite.



Bio-swales collect stormwater runoff and improve run-off water quality.

- 53-5 Trees planted in parking lots should be protected with curbs, bollards or tree grates, or located on landscaped walkways.
- 53-6 Use of permeable paving materials, such as permeable asphalt, grasscrete, and modular pavers, are encouraged to reduce stormwater runoff. Where possible, drainage should be directed into planting areas to increase percolation of water runoff.

Sustainability Guidelines

- 53-7 All planting areas, including those designed to accommodate the 2-foot overhang on parking spaces, should be landscaped with groundcover or other planting materials to reduce stormwater runoff.
- 53-8 The use of bio-swales is encouraged to reduce stormwater runoff.
- 53-9 Light colored paving materials should be considered for use as primary paving materials to reduce heat transmission.

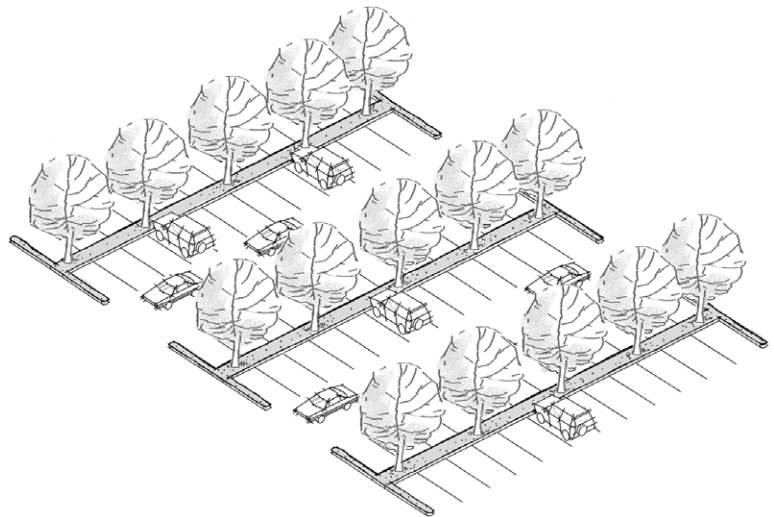

Parking lots should be designed to provide 50% shading after 15 years.

54 Street Trees

Design Principle

Street trees should provide a visual frame to the street and offer shade and comfort to visitors to commercial districts.

Rationale

Street trees soften the appearance of the commercial streetscape, and make it more comfortable for pedestrians by providing essential shade during the summer months.

Design Guidelines

- 54-1 Street trees should be carefully planted and spaced to ensure that commercial businesses are easily visible and accessible.
- 54-2 Street trees that are not planted and maintained by the City, and that project into the public right-of-way, are subject to a City revocable encroachment permit. Contact the Building Division of the City Development Services Department for more information.
- 54-3 Street trees should be easy to maintain, reduce sidewalk damage, and provide a sufficiently large, wide canopy to shade the sidewalks.
- 54-4 Street trees must be pruned to provide a clear space between the lower branches and the sidewalk and roadway to prevent damage and provide a clear view of building signage, ground floor windows, and doors.
- 54-5 Street trees within the public right-of-way must not be trimmed or removed without consulting the City Department of Parks and Recreation Urban Forest Services at 916-433-6345.
- 54-6 Tree species should be suitable for the Sacramento climate, and should be selected for water conservation. Refer to the following lists for recommended species:

Sacramento Tree Foundation

www.sactree.com/treeInfo/treesWeOffer.html

City Department of Parks and Recreation

www.cityofsacramento.org/parksandrecreation/urbanforest/index.html

- 54-7 The *Marysville Boulevard Urban Design Plan* calls for canopy trees to be placed in tree wells within an 8-foot sidewalk. An approved tree list includes the following species: *Platanus acerifolia* 'Bloodgood,' *Washingtonia robusta*, *Zelkova serrata*, *Pyrus kawakamii*, *Magnolia grandiflora*.



Street trees soften the appearance of a commercial street.



Street trees provide welcome shade for pedestrians.



Landscaped areas add to the beauty of commercial districts.

55 Landscape Elements

Design Principle

Landscape elements should be used to foster an attractive and comfortable commercial environment.

Rationale

Landscape elements, such as ornamental plants and water features, help to create visual interest and create an attractive, appealing environment.

Design Guidelines

- 55-1 Landscaping shall conform to the City Municipal Code Section 124.625, "Landscaping and Paving Regulations."
- 55-2 Plant species should be suitable for the Sacramento climate. Low-water landscaping materials are encouraged.
- 55-3 High-maintenance annuals and perennials should be used only as smaller landscape elements.
- 55-4 The full growth of landscaping materials should be anticipated so that trees and shrubs do not conflict with lighting and roofs.
- 55-5 Landscaped areas are preferred over impermeable paved surfaces.
- 55-6 An automatic irrigation system must be installed to provide consistent coverage of all landscaped areas. Automatic controllers with rain shut-off valves will allow for greater water conservation. Irrigation controls should be screened from view by landscaping or other attractive site materials.
- 55-7 Turf and groundcover are more effectively irrigated with a conventional spray system. Head-to-head spray coverage is recommended. Avoid overspray onto sidewalks and adjacent properties.
- 55-8 A drip irrigation system is recommended for shrubs and trees to provide deeper, more even watering. Drip irrigation also permits greater water conservation than a conventional spray system.
- 55-9 Bare soil should be planted or mulched to avoid unnecessary run-off.

Sustainability Guidelines

- 55-10 Deciduous shade trees and shrubs should be planted, where appropriate, to shade the west and south sides of buildings and all paved areas to reduce heat transmission.
- 55-11 New planting strips located between the sidewalk and street should be a minimum of 6 feet wide to promote the health of shade trees.

56 Hardscape Elements and Street Furniture

Design Principle

Hardscape elements and street furniture should be selected and installed so as to increase opportunities for people to congregate and interact, and should complement the surrounding architecture.

Rationale

Hardscape elements and street furniture, such as pedestrian kiosks, benches, transit shelters, newspaper racks, trash cans, and café tables, encourage pedestrian use and increase opportunities for casual social interaction. This informal interaction can enhance the appeal and vitality of commercial districts.

Design Guidelines

- 56-1 Street furniture should be consistent with the character of existing businesses.
- 56-2 Street furniture should be attractive, functional, easy to maintain, high quality, and vandal resistant.
- 56-3 Street furniture must not block the sidewalk or access to parking.
- 56-4 Seating is highly encouraged. A variety of seating alternatives, such as benches, seat walls, and café tables is possible.
- 56-5 Incorporation of public art into site and building design is recommended.
- 56-6 The pattern and texture of ground paving materials should fit the context of the district. Use of high-quality brick, stone, textured concrete, terrazzo tile, or other decorative pavers is encouraged.
- 56-7 Hardscape materials that can endure Sacramento's intense weather conditions should be selected.
- 56-8 Bicycle racks that complement other street furniture should be provided.
- 56-9 Street furniture should complement the Mission style of architecture specified by the Marysville Boulevard Urban Design Plan.

Sustainability Guidelines

- 56-10 Pervious concrete should be used, when feasible, because it has better reflectivity, reducing heat transmission and stormwater runoff.
- 56-11 The use of recycled paving materials is encouraged.



Seating can consist of conventional benches.



Trash receptacles should be provided at regular intervals



Seating can even be combined with public art.

This Page Intentionally Left Blank

Appendices

Appendix A — Additional Resources	94
General Planning Resources	94
Commercial and Home Improvement Funding	95
Manufactured Homes	96
Appendix B — Predominant Residential	
Architectural Styles	97
Ranch	98
Minimal Traditional	99
Appendix C — Predominant Commercial	
Architectural Style	100
California Mission Revival	101
Appendix D — Sustainability Through High Performance	
Building Design	102
Appendix E — Glossary of Terms	104

APPENDIX A — ADDITIONAL RESOURCES

These resources provide more information about the neighborhoods, as well as relevant City programs and ordinances.

General Planning Resources

Sacramento Municipal Code

Title 17 of the Sacramento Municipal Code contains information relevant to development standards, including height limits and setbacks. The code is available at:

<http://cityofsacramento.org/dsd/citycode.htm>

Go to the zoning code section.

Implementation Plan

The *2005-2009 Del Paso Heights Implementation Plan* acts as the operating plan for the Sacramento Housing and Redevelopment Agency (SHRA) with regard to the Del Paso Heights neighborhood. The document outlines goals, specific projects, and proposed costs for implementation. The plan is available at:

www.shra.org/Content/CommunityDevelopment/ImplPlanTOC.htm

Marysville Boulevard Urban Design Plan

Approved in 1998, the *Marysville Boulevard Plan* provides guidelines for streetscape improvements to the portion of Marysville Boulevard between Arcade Creek and Interstate 80. In addition to street upgrades, the Plan specifies signage, gateway, lighting, landscaping, and street furniture improvements. For a copy of the plan, contact SHRA at (916) 440-1322.

Del Paso Nuevo Special Planning District

Del Paso Nuevo Special Planning District is subject to its own set of guidelines that address residential and commercial design and development within its boundaries. For a copy of the guidelines, contact SHRA at (916) 440-1322.

Commercial and Home Improvement Funding

Commercial Revitalization Program

This SHRA program offers free architectural and construction management services for business owners interested in improving the appearance and function of older commercial buildings. Property owners must invest a minimum of \$10,000 in improvements to be eligible. Funding for improvements is provided as a matching rebate up to \$50,000. For more information, contact SHRA at (916) 440-1322.

Grow Sacramento Fund

The Grow Sacramento Fund (GSF) is a non-profit lender providing small business loans under the U.S. Small Business Administration's 7(a) program. GSF offers technical assistance and provides loans between \$25,000 and \$2,000,000 at market rate financing for new and expanding businesses in the City and County of Sacramento. Loans may be used to acquire land and buildings, make leasehold improvements, and purchase machinery and equipment. For more information, contact SHRA at (916) 440-1322.

Targeted Commercial Corridors

Older commercial corridors are key to the economic vitality of the city. Marysville Boulevard is a Targeted Commercial Corridor, which makes it eligible for technical assistance and public funding for commercial development. For more information, contact the City at (916) 808-7063.

Home Repair and Improvement Programs

SHRA administers several home repair and improvement programs, including emergency repair, accessibility, and repair assistance for seniors. Homeowner rehabilitation loans are also available. To learn more about these programs, see the SHRA website or contact the SHRA at (916) 264-1500.

www.shra.org/Content/Housing/HomeRepair/HomeRepairTOC.htm

Historic Preservation Standards

U.S. Secretary of the Interior's Standards for Rehabilitation

The U.S. Secretary of the Interior sets the standard for the rehabilitation and maintenance of historic structures. While these Design Guidelines are not intended to set standards for historic structures, some of the information on this National Park Service website may be useful to individuals who want to learn more about how to protect residential properties that are 50 years old or older.

www.cr.nps.gov/tps/standguide/rehab/rehab_index.htm

City of Sacramento Historic Preservation

The City's Historic Preservation Department oversees the environmental review of potentially historic structures 50 years old or older. Structures proposed for demolition may also be subject to review as potentially eligible for listing on the City's register of historic landmarks and contributing resources. The City has adopted the Secretary of the Interior's Standards for review of historic preservation projects under Sacramento Municipal Code, Chapter 15.124, which can be found at:

www.qcode.us/codes/sacramento/view.php?topic=15-15_124

Work done in compliance with the U.S. Secretary of the Interior's Standards is considered to have a less than significant impact for purposes of environmental review under the California Environmental Quality Act (CEQA).

Manufactured Homes

U.S. Department of Housing and Urban Development

www.hud.gov/offices/hsg/sfh/mhs/mhshome.cfm

Manufactured Housing Institute

The 2000 Manufactured Housing Improvement Act

www.manufacturedhousing.org/lib/showtemp_detail01.asp?id=106&cat=6

California Health and Safety Code

Mobilehomes-Manufactured Housing Act of 1980 (Division 13, Part 2 of the California Health and Safety Code)

www.leginfo.ca.gov/.html/hsc_table_of_contents.html

California Manufactured Housing Institute

www.cmhi.org

National Association of Homebuilders (NAHB)

The NAHB website has many resources. Go to “search” and type in “manufactured” or “modular” to call up articles on the subject.

www.nahbrc.com

APPENDIX B — PREDOMINANT RESIDENTIAL ARCHITECTURAL STYLES

The most typical existing Del Paso Heights residential architectural styles are detailed in this section. The architectural styles shown are graphically represented by photos taken within the redevelopment area. The examples are not *intended to be emulated in new construction in their pure form*, but are provided for informational purposes to help applicants better understand and respond to the existing residential context.

Appendix B

Ranch

The Ranch style home was popular from the 1950s through the 1970s. Low and rambling, the Ranch home occupied more square footage than previous architectural styles. Ranch style homes can have a simple rectangular floor plan, or an L-, T-, or U-shape, with the attached garage usually as one arm of these more complex layouts.

Ranch design features:

- wide, horizontal facade
- built-in garage common
- single story
- low-pitched hipped, cross-gabled, and side-gabled roofs
- moderate to wide eave overhang
- wood or brick wall cladding (sometimes in combination)
- ribbon windows
- picture windows
- minimal front entry features



Ranch home

Minimal Traditional

Minimal Traditional was a popular style from the 1930s into the 1950s. The homes were inexpensive to build and allowed a greater proportion of the general populace to enjoy home ownership.

Their styling reflects the influence of Tudor, Colonial Revival, and Craftsman Cottages that were popular through the 1920s. However, Minimal Traditional homes are considerably more streamlined and display simpler decorative features than their predecessors.

Minimal Traditional design features:

- low-pitched roof
- usually one story
- minimal decoration
- side gable roof, sometimes with front crossing gable
- minimal overhang of eaves
- wood or brick cladding
- entry porches

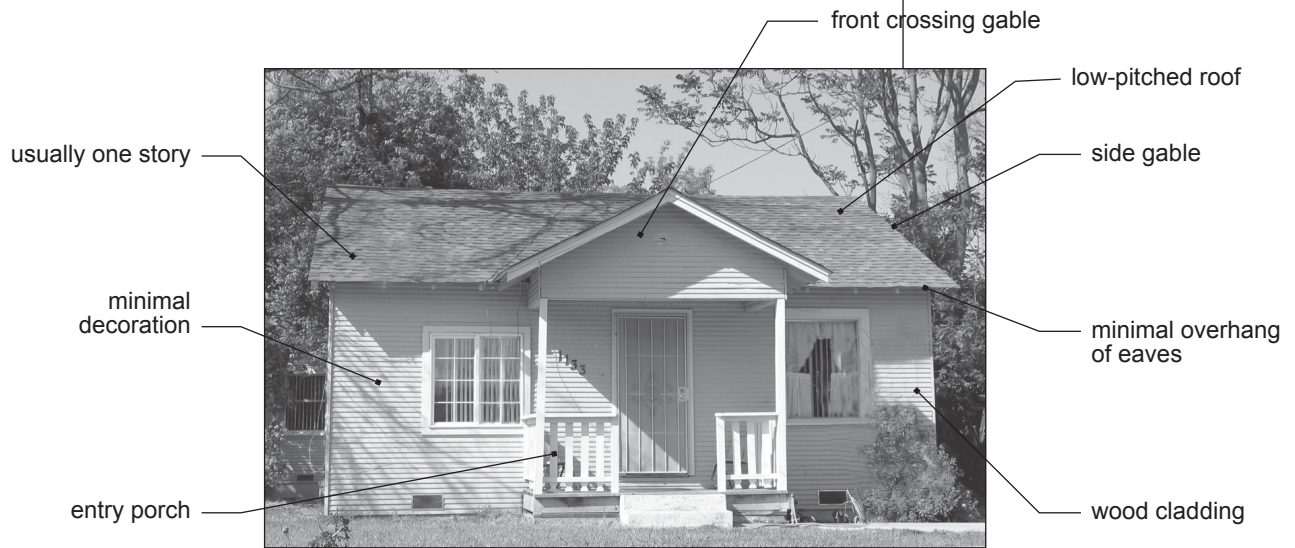

Minimal Traditional home

APPENDIX C — PREDOMINANT COMMERCIAL ARCHITECTURAL STYLE

The architectural style depicted provides developers and designers with information on the existing Del Paso Heights commercial context that should be considered for commercial infill and renovations. The example shown in this section is not intended for precise duplication in new construction, but is provided for informational purposes only.

While the Marysville Boulevard Urban Design Plan states that new commercial buildings should be influenced by the California Mission Revival architectural style, variation and interpretation of this stylistic influence is desirable.

California Mission Revival

The California Mission Revival style originated in southern California and was considered the “California counterpart” to the Colonial Revival style popular in the northeastern United States in the early 20th century. Rather than imitating design influences imported from the East Coast, this style was derived from historic Southwestern influences, including Puebloan and Spanish mission architecture. Grant Union High School is a notable example in Del Paso Heights.

California Mission Revival design features:

- dormers and roof parapets based on the arching and fluted shapes of Spanish missions;
- wide, overhanging eaves;
- exposed rafters;
- red-tiled roof;
- stucco walls; and
- arched windows and doors on ground level.



California Mission Revival: Grant Union High School

APPENDIX D — SUSTAINABILITY THROUGH HIGH PERFORMANCE BUILDING DESIGN

The City encourages builders and owners to construct structures that are designed, built, renovated, operated or reused in an ecological and resource-efficient manner. Buildings should be designed to meet certain objectives such as protecting occupant health; using energy, water, and other resources more efficiently; and reducing the overall impact to the environment. These design features are not only the responsible thing to do for the environment and our community but they will also help lower expenses and create a more comfortable living space.

While the City has included a number of sustainability design guidelines in this document, this appendix includes more resources to assist in building cost-effective, ecological and resource-efficient buildings.

Whole Building

Build It Green, New Home Construction Green Building Guidelines, December 2005

www.builditgreen.org/newconstructionguidelines.pdf

Celery Design Collaborative, *San Mateo Countywide Guidelines: Sustainable Buildings*, February 2004.

www.recycleworks.org/greenbuilding/gbg_intro.html

U.S. Green Building Council's Leadership in Energy and Environmental Design (LEED) Program

The LEED program is intended to promote "green" design and construction practices that can result in more environmentally sensitive site design, water quality and management practices, energy conservation, and the use of sustainable materials. For more information, go to:

www.usgbc.org/DisplayPage.aspx?CategoryID=19

Energy

Sacramento Municipal Utility District (SMUD)

SMUD offers a variety of resources, including a reference room, educational workshops and seminars, and a program that promotes the use and evaluation of innovative technologies by consumers.

Overview of SMUD Programs

www.smud.org/education/

Promotions, Rebates, and Financing Website

www.smud.org/residential/saving/rebate.html

Residential Solar Website

www.smud.org/green/solar/index.html

Lighting

California Lighting Technology Center, Residential Lighting Design Guide,
Best Practice and Lighting Design to Help Builders Comply with California's 2005 Title 24 Energy Code
<http://cltc.ucdavis.edu/title-24-residential-lighting-design-guide>

Energy Design Resources, Day-lighting Design Brief
<http://www.energydesignresources.com/resource/19/>

Water

California Urban Water Conservation Council, H2ouse: Water Saver Home Website
www.h2ouse.org

Landscaping

Sacramento Tree Foundation, Publications and Guidelines Website,
www.sactree.com/aboutUs/publications.html

Materials

California Integrated Waste Management Board, Construction and Demolition (C&D) Debris Recycling
Specifications
www.ciwmb.ca.gov/ConDemo/Specs/

Green Project Specifications
www.ciwmb.ca.gov/greenbuilding/Specs/

Green Product Directories
www.ciwmb.ca.gov/greenbuilding/ToolKit.htm#Product

APPENDIX E — GLOSSARY OF TERMS

Arcade: a roofed passageway with shops on either side.

Balustrade: a railing with supporting columns known as balusters.

Capital: the uppermost section of a column or pillar, which is often decorated.

Cladding: the protective exterior surface of a building, such as wood, metal, brick, or stucco.

Cornice: a crowning, overhanging projection from the roof, usually the uppermost segment of the entablature in classical architecture.

Dormer: a structure projecting from a sloping roof that usually includes a small gable with one or more vertical windows.

Facade: the exterior surface of a building.

Gable: the triangular end of a wall above the eaves that abuts the roofline above it.

Infill: new construction on vacant or redeveloped lots within an established neighborhood.

Manufactured Home: a factory-built home that is shipped to and installed at the site.

Massing: the arrangement of the physical volume of a building.

Mullion Window: a window with vertical and horizontal strips that divide the window into separate panes.

Pitch (of a roof): recorded as a ratio of vertical to horizontal measures. A 5:12 roof, for instance, means 5 inches of vertical rise for every 12 inches of horizontal run.

Plinth: the solid base of a column or pillar, which is often square, round, or rectangular.

Portico: a range of columns or arches connected to or merged with the facade of a building that forms a walkway or porch.

Ribbon Window: A horizontal series of narrow windows across the facade of a building.

Running Gear: the tires, wheels, axles, and springs that allow a manufactured home to be moved from place to place without dismantling it.

Setback: (1) The prescribed distance between the lot line and the edge of the building's footprint. (2) The horizontal distance between the exterior wall of one floor and the next story exterior wall.

Sidelight: an area of framed glass along the sides of a door.

Site-built: constructed at the site of the building without use of prefabricated sections.

Streetwall: the line or "wall" formed by the front facades of buildings on a block or street.

Transom: an area of framed glass at the top of a door or window.